

Partially hyperbolic diffeomorphisms with a compact center foliation with finite holonomy

Doris Bohnet

► **To cite this version:**

Doris Bohnet. Partially hyperbolic diffeomorphisms with a compact center foliation with finite holonomy. Dynamical Systems [math.DS]. Universität Hamburg, 2011. English. tel-00782664

HAL Id: tel-00782664

<https://tel.archives-ouvertes.fr/tel-00782664>

Submitted on 30 Jan 2013

HAL is a multi-disciplinary open access archive for the deposit and dissemination of scientific research documents, whether they are published or not. The documents may come from teaching and research institutions in France or abroad, or from public or private research centers.

L'archive ouverte pluridisciplinaire **HAL**, est destinée au dépôt et à la diffusion de documents scientifiques de niveau recherche, publiés ou non, émanant des établissements d'enseignement et de recherche français ou étrangers, des laboratoires publics ou privés.

Partially hyperbolic systems with a compact center foliation with finite holonomy

Dissertation
Zur Erlangung des Doktorgrades
der Fakultät für Mathematik, Informatik und
Naturwissenschaften

der
Universität Hamburg

vorgelegt im Fachbereich Mathematik
von
DORIS BOHNET

aus Konstanz

Hamburg 2011

Als Dissertation angenommen vom Fachbereich Mathematik
der Universität Hamburg
aufgrund der Gutachten von:
Dr. Roland Gunesch,
Prof. Dr. Christian Bonatti

Hamburg, den 12.12.2011.

Prof. Dr. Ingenuin Gasser
Leiter des Fachbereichs Mathematik

Contents

Vorwort	6
Introduction	11
1 Preliminaries	16
1.1 Compact foliations and homeomorphism groups	16
1.2 Partially hyperbolic systems	26
1.2.1 Definitions and basic properties	26
1.2.2 Dynamical coherence for partially hyperbolic systems with a compact center foliation with finite holonomy	30
1.2.3 Further remarks	35
1.3 Dynamics on the leaf space	37
1.3.1 Compact center leaves with trivial holonomy	39
1.3.2 Compact center leaves with finite holonomy	44
1.3.3 Shadowing Lemma for compact center foliations with finite holonomy	46
1.4 Orientability and covering spaces	69
2 Compact center foliations with finite holonomy under restric- tions on the codimension	72
2.1 Main theorems	72
2.2 General lemmata	75
2.2.1 Transitivity on the leaf space	78
2.3 Codimension-2 center foliation.	84
2.4 Codimension-3 center foliation	88
2.5 Codimension-(1+k) center Foliation	93
2.6 Codimension-(2+2) center Foliation	113
Outlook	118
Bibliography	122

Contents

Zusammenfassung	123
Lebenslauf	124

List of Figures

1.1	Failure of dynamical coherence	32
2.1	Orientation-reversing holonomy	77
2.2	Proof of central transitivity (1)	82
2.3	Proof of central transitivity (2)	84
2.4	Accumulation of unstable plaques	90

Vorwort

Die vorliegende Arbeit ist der Klassifikation partiell hyperbolischer Diffeomorphismen gewidmet. Die Untersuchung partiell hyperbolischer Diffeomorphismen ist ein Teil der Theorie der dynamischen Systeme. Unter einem dynamischen System versteht man ein beliebiges System, zum Beispiel ein physikalisches oder ein ökonomisches, das sich in Abhängigkeit von der Zeit verändert. Wir betrachten nur dynamische Systeme mit diskreter Zeit. Demnach lässt sich ein dynamisches System durch den Raum M der Zustände des Systems und durch eine Abbildung $f : M \rightarrow M$ beschreiben, die die Veränderung des Systems in einer Zeiteinheit erfasst. Diese Arbeit beschränkt sich auf differenzierbare dynamische Systeme, bei denen f ein Diffeomorphismus und M eine kompakte glatte Mannigfaltigkeit ist.

Die Theorie der dynamischen Systeme untersucht das langfristige Verhalten eines Systems: Gibt es einen Zustand oder eine Menge von Zuständen, denen sich das System unabhängig von seinem Anfangszustand annähert? Ist das System stabil gegenüber kleinen Störungen von f oder geringfügigen Änderungen des Anfangszustandes? In den 1960er Jahren hat man festgestellt, dass strukturstabiles dynamisches Verhalten eng mit dem Begriff der Hyperbolizität korreliert. In den darauffolgenden Jahren sind deshalb sogenannte hyperbolische dynamische Systeme intensiv studiert worden, und ihr Verhalten ist heute gut verstanden. In der Folge tauchten in den 1970er Jahren Ideen auf, den Begriff der Hyperbolizität abzuschwächen, so dass eine größere Klasse von Systemen erfasst wird, aber dennoch viele Eigenschaften hyperbolischer Systeme erhalten bleiben. In diesem Zusammenhang sei an den Begriff der partiellen Hyperbolizität erinnert, eingeführt von Pugh und Shub in [PS72] und unabhängig davon von Brin und Pesin in [BP74], sowie an den Begriff der nichtuniformen Hyperbolizität von Pesin in [Pes77], heute auch als *Pesin-Theorie* bekannt, und an das *dominated splitting*, entwickelt von Mañé in [Mañ84].

Der Gegenstand dieser Arbeit sind differenzierbare partiell hyperbolische Systeme. Ein glattes dynamisches System $f : M \rightarrow M$ wird partiell hyperbolisch

genannt, falls sein Tangentialbündel in drei nichttriviale, df -invariante Unterbündel zerfällt, genannt stabiles, instabiles und zentrales Unterbündel, so dass df Vektoren des stabilen Unterbündels stärker kontrahiert als Vektoren in zentrale Richtung sowie Vektoren in instabile Richtung stärker streckt als Vektoren in zentrale Richtung. Die stabilen und instabilen Unterbündel sind eindeutig integrabel zu f -invarianten stabilen und instabilen Blätterungen, während das zentrale Unterbündel nicht einmal in einem schwachen Sinne integrabel sein muss. Diese Arbeit beschränkt sich auf Systeme, die eine f -invariante Zentrumsblätterung tangential zum zentralen Unterbündel besitzen. Die Eigenschaften der Zentrumsblätterung sind eine Möglichkeit, um partiell hyperbolische Systeme zu klassifizieren, und dieser Weg soll in dieser Arbeit beschränkt werden. Da sich die bekannten Beispielklassen vor allem hinsichtlich der Eigenschaften ihrer Zentrumsblätterung unterscheiden, scheint dies eine sinnvolle Kategorisierung zu sein.

Am Anfang dieser Arbeit stand die Idee, partiell hyperbolische Systeme auf hyperbolische Systeme zurückzuführen, indem man sich der zentralen Richtung, die bei allen Beweisen Probleme bereitet, zu entledigen versucht. Mathematisch formuliert geht man zum Quotientenraum über, der entsteht, wenn man jeweils alle Punkte auf einer Zentrumsmannigfaltigkeit miteinander identifiziert. In diesem Quotientenraum kann man mit gutem Recht ein hyperbolisches Verhalten des induzierten Systems erwarten, auch wenn Glattheitseigenschaften auf dem Weg der Quotientenbildung verloren gehen. Im Allgemeinen, und hier liegt nun das Problem, ist der Quotientenraum einer Blätterung in den meisten Fällen nicht einmal ein Hausdorffraum. Doch die Hausdorffeigenschaft ist sicherlich ein Minimum dessen, was man von einem Raum verlangen muss, um in ihm sinnvoll die Dynamik eines Systems untersuchen zu können. Deshalb ist es notwendig zu fordern, dass alle Zentrumsmannigfaltigkeiten kompakt sind und endliche Holonomie besitzen. Was dies im Einzelnen ist und was es impliziert, wird im folgenden einleitenden Kapitel ausführlich dargelegt. An dieser Stelle soll es zunächst genügen festzuhalten, dass die Zentrumsblätterung weitere zusätzliche Eigenschaften besitzen muss. Unter diesen Bedingungen induziert dann f eine Abbildung F auf dem Quotientenraum, die in einem topologischen Sinne viele hyperbolische Eigenschaften aufweist. Die Strategie, die den folgenden Beweisen zugrunde liegt, ist, die hyperbolischen Eigenschaften immer dann auszunutzen, wenn die zentrale Richtung Schwierigkeiten bereitet, gleichzeitig aber auf f und die glatten invarianten Blätterungen in M zurückzugreifen, sobald der Beweis Glattheitseigenschaften erfordert.

Die Annahme kompakter Zentrumsmannigfaltigkeiten scheint sehr restriktiv,

ist aber, obwohl theoretisch motiviert, auch von praktischer Bedeutung, da eine wichtige Beispielklasse partiell hyperbolischer Systeme, die sogenannten Schiefprodukte, kompakte Zentrumsmanifoldigkeiten besitzt. Die Schiefprodukte sind in den letzten Jahren aus vielen Gründen, wie z.B. Existenz von SRB-Maßen, intensiv studiert worden. Diese Arbeit ist nun ein Schritt hin zu einem besseren Verständnisses des Zusammenhanges zwischen partiell hyperbolischen Systemen mit kompakter Zentrumsblätterung und Schiefprodukten bzw. endlichen Überlagerungen von Schiefprodukten. Im Falle einer dreidimensionalen Mannigfaltigkeit hat Pujals auf einer Konferenz im Jahr 2001 die Vermutung geäußert, dass beide identisch sind, die auch durch Arbeiten von Bonatti und Wilkinson in [BW05a] in leicht abgeänderter Form bestärkt wird.

Die folgenden drei Ergebnisse sind die wichtigsten, die in dieser Arbeit erzielt werden konnten:

Ergebnisse:

1. Ein partiell hyperbolisches System $f : M \rightarrow M$ mit einer kompakten Zentrumsblätterung mit endlicher Holonomie ist dynamisch kohärent, d.h. es existieren Blätterungen zum zentralinstabilen und zum zentralstabilen Unterbündel. Dieses Ergebnis findet sich als Theorem 1.24 im Kapitel 1.
2. Weiter zeigen wir das Beschattungslemma in Theorem 1.65 in Kapitel 1 für ein partiell hyperbolisches System $f : M \rightarrow M$ mit einer kompakten Zentrumsblätterung mit endlicher Holonomie.
3. Es werde weiter angenommen, dass das instabile Unterbündel eindimensional ist. Dann kann ein partiell hyperbolisches System $f : M \rightarrow M$ mit einer kompakten Zentrumsblätterung mit endlicher Holonomie auf einer zweifachen Überlagerung zu einem partiell hyperbolischen System \tilde{f} hochgehoben werden, so dass die hochgehobene Zentrumsblätterung nur triviale Holonomie besitzt. Die Quotientenabbildung beschreibt ein Faserbündel, und das hochgehobene System \tilde{f} induziert einen hyperbolischen Torusautomorphismus auf dem Quotientenraum. Lokal sieht das System also in etwa aus wie ein Schiefprodukt aus einem hyperbolischen Torusautomorphismus und der Wirkung von f auf der Zentrumsmanifoldigkeit. Dieses Ergebnis ist in Theorem A, Theorem B und Theorem C enthalten, die im Kapitel 2 vorgestellt und im Anschluss daran bewiesen werden. Dabei ist Theorem C dasjenige mit dem stärksten Resultat und impliziert im Wesentlichen Theorem A und

Theorem B.

Das obige Ergebnis kann nicht auf Systeme mit höherdimensionaler instabiler Richtung übertragen werden, da der Beweis auf einem Resultat über sogenannte Anosov-Diffeomorphismen der Kodimension 1 beruht, also hyperbolische Diffeomorphismen mit eindimensionaler instabiler Richtung. Bei jedem Versuch, das Ergebnis zu verallgemeinern, tauchen mindestens an den folgenden drei Stellen Schwierigkeiten auf:

1. Eine endliche Holonomie kann man hier als eine stetige Gruppenwirkung einer endlichen Gruppe von periodischen Homöomorphismen auf einer Untermannigfaltigkeit in M verstehen, die transversal zur Zentrumsblätterung eingebettet ist. Es ist wenig im Allgemeinen über derartige Gruppenwirkungen bekannt, falls die Dimension der Untermannigfaltigkeit größer als zwei ist. Falls also die Zentrumsblätterung eine höhere Kodimension besitzt, wird es sehr schnell schwierig, irgendetwas a priori über die Natur der Holonomiegruppe, die Art der Gruppenwirkung und die Fixpunkt Mengen auszusagen.
2. Um zu zeigen, dass die Holonomie der Zentrumsblätterung in einer endlichen Überlagerung verschwindet, benötigt man, dass die induzierte Abbildung F auf dem Quotienten transitiv ist. Dies mag im Falle einer höherdimensionalen instabilen Richtung nicht korrekt sein. Ist die Holonomie nicht trivial, ist auch der Quotientenraum keine Mannigfaltigkeit.
3. Um zu zeigen, dass der Quotientenraum ein Torus ist, wird die universelle Überlagerung der Mannigfaltigkeit konstruiert und gezeigt, dass die Automorphismengruppe der Überlagerung und damit die Fundamentalgruppe des Quotientenraums \mathbb{Z}^q ist, wobei q die Kodimension der Zentrumsblätterung bezeichnet. Zur Bestimmung dieser Gruppe wird aber maßgeblich ausgenutzt, dass ein Unterbündel eindimensional ist und dass jede instabile Mannigfaltigkeit dicht im Raum ist, wofür wiederum die Transitivität von F benötigt wird.

Es kann zudem gezeigt werden, dass im Falle eines zweidimensionalen instabilen Bündels eine zweifache Überlagerung nicht ausreicht, um Zentrumsblätter mit nichttrivialer Holonomie zu beseitigen. Vielmehr können f -invariante Untermannigfaltigkeiten aus Zentrumsblättern mit nichttrivialer Holonomie auftauchen. An diesem Sachverhalt erkennt man, dass das obige Ergebnis in der jetzigen Formulierung nicht auf höherdimensionale Unterbündel

übertragen werden kann.

Das Thema dieser Arbeit war anfangs durch die Frage motiviert, ob es nicht möglich ist, ohne Beschränkung der Allgemeinheit triviale Holonomie der Zentrumsblätterung vorauszusetzen, d.h. ob es stets eine endliche Überlagerung gibt, auf die das System hochgehoben werden kann, so dass dort die Holonomie verschwindet. Diese Frage mag auf den ersten Blick sehr naheliegend erscheinen, dennoch ist sie nicht ad hoc zu beantworten. Dies zeigt sich auch darin, dass sie auch schon in weiteren aktuellen Arbeiten wie [Car10] und [Gog11] aufgetaucht ist, ohne in voller Allgemeinheit beantwortet worden zu sein. Es sei anzumerken, dass im Fall einer kompakten Blätterung mit endlicher Holonomie, ohne Annahme eines partiell hyperbolischen Systems, nicht unbedingt eine endliche Überlagerung existieren muss, so dass dort die Holonomie verschwindet. Um diese Frage zu beantworten, muss also die Dynamik des Systems ebenso wie Eigenschaften der Blätterung und ihr Zusammenspiel ausgenutzt werden. Obwohl auch diese Arbeit die Eingangsfrage nicht vollständig beantwortet, wird hiermit ein besseres Verständnis für die weitere Untersuchung dieser Klasse von partiell hyperbolischen Systemen gewonnen und eine mögliche Richtung für die Beantwortung dieser Frage vorgezeichnet.

Im folgenden ersten Kapitel werden alle Voraussetzungen dieser Arbeit erläutert und vorbereitende Aussagen bewiesen. Davon sind zwei, der Beweis der dynamischen Kohärenz und des Beschattungslemmas, unabhängig von ihrer Anwendung in dieser Arbeit von allgemeiner Bedeutung für die Theorie der partiell hyperbolischen Systeme. Im zweiten Kapitel wird dann das Hauptergebnis dieser Arbeit ausführlich bewiesen. Dabei werden die Fälle von Kodimension-2, Kodimension-3 und Kodimension-($k+1$) getrennt behandelt, weil sich die Beweise in Techniken und Schwierigkeitsgrad erheblich unterscheiden und in den ersten beiden Fällen auf bekannte Resultate zurückgegriffen werden kann. Im letzten Abschnitt des zweiten Kapitels wird der Fall eines partiell hyperbolischen Diffeomorphismus mit jeweils zweidimensionalem instabilen und stabilen Unterbündel erläutert.

Introduction

This thesis is an attempt to make a step forward towards a classification of partially hyperbolic systems. The investigation of partially hyperbolic systems is part of the theory of dynamical systems. A dynamical system is any kind of system, e.g. physical or economical, which changes time-dependently. We only consider systems with discrete time. Hence, a dynamical system consists of a space M of states and a map f which describes the changes of the state of the system in one time unit. This thesis is limited to smooth dynamical systems where f is a diffeomorphism and M a compact smooth manifold.

The theory of dynamical systems tries to answer how the dynamical system changes in the course of time. Does the system converge to an equilibrium state, independent of its initial state? Is the behavior of the system stable under small changes of the initial conditions? In the 1960s it was shown that stable dynamical behavior is closely related to hyperbolicity. So, in the following years, hyperbolic dynamical systems were intensely studied and are nowadays quite well understood. Since the 1970s the concept of hyperbolicity has been tried to be relaxed in such a way that a larger class of systems is covered and at the same time, a lot of properties of hyperbolic systems are conserved. We should remind in this context of partial hyperbolicity introduced by Pugh and Shub in [PS72] and independently by Brin and Pesin in [BP74], of non-uniform hyperbolicity initiated by Pesin in [Pes77] and of dominated splitting developed by Mañé in [Mañ84].

As indicated above, the present work deal with smooth partially hyperbolic dynamical systems $f : M \rightarrow M$. A smooth dynamical system $f : M \rightarrow M$ is called partially hyperbolic if its tangent bundle splits into three non-trivial, df -invariant subbundles, called the stable, unstable and center bundle, such that df contracts uniformly vectors in the stable direction, expands uniformly vectors in the unstable direction and contracts and/ or expands in a weaker way vectors in the center direction. The stable and unstable foliations integrate to unique f -invariant stable and unstable foliations, while the center bundle might not be integrable, even in a weak sense. But we restrict our-

selves to the case of a partially hyperbolic system where a center foliation tangent to the center bundle exists. One possibility to classify such partially hyperbolic systems is by the properties of their center foliation.

The idea that motivated this thesis is to get rid of the mysterious behavior of the center foliation by just dividing it out. Formulated in a more mathematical way, we identify points on the same center leaf and thereafter work in the resulting quotient space of the center foliation. In this quotient we expect a hyperbolic behavior of the induced map with all its useful and well-known properties. But generally, the quotient space of a foliation has very little structure and might not even be Hausdorff. But as the Hausdorff property is the minimum for any serious investigation of the topological dynamics, we have to assume that all center leaves are compact and have finite holonomy in order to get a compact Hausdorff space as quotient space. We define and explain all these notions in the first chapter of this work. At this time it shall suffice to say that we have to assume a number of certain additional properties of the center foliation. Then it is possible to identify points on the same center leaf and obtain a Hausdorff space. The smooth dynamical system f induces a continuous dynamical system F on this quotient which reveals a lot of typical hyperbolic features. The strategy is to use the hyperbolic behavior in the quotient whenever the center might cause difficulties during a proof and to enjoy the existence of foliations with smooth leaves and a smooth map f when the assumption of differentiability is unavoidable. The restriction to compact center foliations is not at all unmotivated as it is conjectured by Pujals in 2001 that all partially hyperbolic systems on three-dimensional manifolds are perturbations of one of the following three examples or finite lifts of them: Time-1 map of an Anosov flow, certain toral automorphisms and certain skew products. The last class of partially hyperbolic system, the skew products, all have compact leaves and have been of great interest in the last years. So, one may expect that all partially hyperbolic systems with compact leaves are perturbations of a skew product or can be lifted to such a system in a finite cover. This question is at present far to be solved. But the present thesis supports the conjecture above and may be regarded as a step towards proving this conjecture.

Main Results:

1. Let $f : M \rightarrow M$ be a partially hyperbolic system with a f -invariant compact center foliation with finite holonomy. Then the diffeomorphism f is dynamically coherent, i.e. there exist foliations tangent to the center-stable and center-unstable subbundles. This result is stated as Theorem 1.24 in Chapter 1.

2. We show the Shadowing Lemma in Theorem 1.65 for a partially hyperbolic diffeomorphism f with a f -invariant compact center foliation with finite holonomy.
3. Assuming a one-dimensional unstable (or stable) bundle we show that the partially hyperbolic system $f : M \rightarrow M$, lifted to a 2-cover, fibers over a hyperbolic linear map on the torus. As a consequence, the system looks locally more or less like a skew product of a hyperbolic automorphism and the action of f on the center leaf. This result is contained in Chapter 2 and divided into Theorem A, Theorem B and Theorem C. Theorem C is the strongest result and mostly implies Theorem A and Theorem B.

As the proof depends on a result about so called codimension-one Anosov diffeomorphisms, i.e. hyperbolic diffeomorphisms with a one-dimensional unstable (or stable) bundle the main result of this thesis cannot be extended to a system with higher-dimensional unstable bundle. Difficulties arise at least at three points:

1. A finite holonomy is a continuous group action of a finite group of homeomorphisms on a smoothly embedded disk in the manifold M . We do not know a lot about these so-called continuous transformation groups if the dimension of the disk is greater than 2. For this reason, in case of higher codimensions of the center bundle it is difficult to conclude something a priori about the nature of the holonomy group and the way it acts, for example what its fixed point set is like.
2. The proof for the triviality of any center holonomy is based on the fact that the induced dynamic of F on the quotient space is transitive. This might not be correct in the case of a higher-dimensional unstable bundle. If the center holonomy is not trivial the quotient will not be a manifold.
3. To show that the quotient is a torus the standard way is the construction of a universal cover and then to show that the automorphism group of this cover and hence the fundamental group of the manifold is \mathbb{Z}^q where q denotes the codimension of the center foliation. But to determine this group it is inevitable that one bundle is one-dimensional and the corresponding leaves are dense.

Further, we show that in the case of a two-dimensional unstable bundle a 2-cover is not enough to eliminate center leaves with non-trivial holonomy.

Besides, there can exist f -invariant submanifolds in M which consist of center leaves with non-trivial holonomy. This fact shows that the main result above in the actual form cannot be generalized to higher-dimensional unstable (or stable) bundles.

One motivation for the topic of this thesis was the question if we could restrict ourselves to the case of trivial center holonomy. We could do this without losing generality if we show that any system with finite holonomy can be lifted to a finite cover where the holonomy vanishes everywhere. It should be remarked that a priori - without assuming a partially hyperbolic dynamic on the manifold - such a cover does not exist. So, to answer this question dynamical properties, features of compact foliations with finite holonomy and their interplay have to be utilized at the same time. This question appears under certain additional assumptions in actual work as in the thesis of Carrasco ([Car10]) and a recent article by Gogolev ([Gog11]). This thesis is an attempt to provide a better understanding of how to answer this question.

This work is organized as follows: In the first chapter we introduce and define the setting of the thesis and prove some preliminary results we need in the main proofs. Two of these results, the proof of dynamical coherence and of the Shadowing Lemma, are interesting for the theory of partially hyperbolic systems independent from their application in this thesis. In the second chapter we mainly present the detailed proofs of Theorem A, Theorem B and Theorem C of this thesis. We prove the case of a codimension-2 and codimension-3 center foliation separately as they are more straightforward and easier to handle than the most general case of a one-dimensional unstable bundle. Some interesting techniques only arise in the lower-codimensional cases. In the last section of the second chapter we treat the case of a codimension-4 center foliation where stable and unstable bundle are both two-dimensional.

Acknowledgements. First, I would like to thank Dr. Roland Gunesch who got me interested in dynamical systems and supervised my Diploma thesis. He further encouraged me to start a PhD thesis and supported me during all the time. I would like to express my gratitude to Prof. Dr. Christian Bonatti who I visited at the half time of my thesis with a quite naive question which has been the offspring for the main results inside the thesis. And instead of just answering the question he has become supervisor of this thesis since that visit. He taught me to make my ideas more precise and concrete, not to mention the time he spent with me discussing my thesis. Further, I owe the contact with a lot of interesting mathematicians of my field to him thanks to his invitation to the Conference *Beyond uniform hy-*

perbolicity in Luminy this year. Due to a scholarship of DAAD I was able to visit Keith Burns and Amie Wilkinson at the Northwestern University in Evanston, USA, and I would like to thank them both for their time and interest in my topic although my ideas were quite confuse at that moment. Nevertheless, that visit was the start of getting started with my thesis. For his helpfulness and support in all kind of questions related to this thesis I thank Dr. Eugen Stumpf. Finally, I would not have been able to finish this thesis without the help of my husband Dr. Ilja Bohnet who took care of Jan und Ida more than once during several days and always encouraged me. The same is true for my parents Drs. Gisela and Heiko Plate who cared for Jan during months in the last years of studies, and my visit to Northwestern wouldn't have been possible without their help in any sense. My last thanks go to little Jan and Ida who were the offspring of distraction and I would have spent the last years with less joy and happiness without them.

1

Preliminaries

In this chapter we discuss the mathematical concepts and their properties we need in order to prove our results. During the chapter we prove a lot of smaller lemmata which are used during the main proofs. Additionally, two theorems, important by themselves, are shown in this chapter: We prove dynamical coherence in Theorem 1.26 and the Shadowing Lemma in Theorem 1.65, both in the general setting of a partially hyperbolic diffeomorphism with a compact center foliation with finite holonomy.

1.1 Compact foliations and homeomorphism groups

As we deal with stable, unstable and center foliations some concepts of foliation theory are necessary and are introduced here. In particular, we utilize in our proofs the compactness and finite holonomy of the center foliation by applying the Reeb Stability Theorem.

Definition of foliation. Let M be a n -dimensional manifold. A *foliated chart* on M of codimension q is a pair (U, ϕ) where $U \subset M$ is open and $\phi : U \rightarrow B^{n-q} \times B^q \subset \mathbb{R}^{n-q} \times \mathbb{R}^q$ is a diffeomorphism where B^{n-q} denotes a rectangular neighborhood in \mathbb{R}^{n-q} and B^q a rectangular neighborhood in \mathbb{R}^q . The set $\phi^{-1}(B^{n-q} \times \{y\})$ with $y \in B^q$ is called a *plaque* of this foliated chart. Let $\mathcal{F} = \{L_i\}_{i \in I}$ be a decomposition of M into connected, topologically immersed submanifolds of dimension $k = n - q$. Suppose that M admits an atlas $\{U_\alpha, \phi_\alpha\}_{\alpha \in \mathfrak{A}}$ of foliated charts of codimension q such that for each $\alpha \in \mathfrak{A}$ and each $i \in I$ the set $L_i \cap U_\alpha$ is a union of plaques. Then \mathcal{F} is said to be a *foliation* of M of codimension q and dimension k . Each L_i is called a *leaf* of the foliation. If the foliated atlas is of class C^r , $0 \leq r \leq \infty$ or $r = \omega$,

then the foliation \mathcal{F} is said to be of class C^r . This implies that every leaf is a C^r -immersed submanifold.

Two foliated atlases \mathfrak{U} and \mathfrak{V} on M of the same codimension and smoothness C^r are called *coherent* if their union $\mathfrak{U} \cup \mathfrak{V}$ is a C^r -foliated atlas. Coherence is an equivalence relation.

A foliated atlas $\mathfrak{U} = \{U_\alpha, \phi_\alpha\}_{\alpha \in \mathfrak{A}}$ of class C^r is said to be *regular* if for each $\alpha \in \mathfrak{A}$ the closure \overline{U}_α is a compact subset of a foliated chart (W_α, ψ_α) and $\phi_\alpha = \psi_\alpha|_{U_\alpha}$, the cover $\{U_\alpha\}_{\alpha \in \mathfrak{A}}$ is locally finite and if (U_α, ϕ_α) and (U_β, ϕ_β) are elements of \mathfrak{U} , then the interior of each closed plaque $P \subset \overline{U}_\alpha$ meets at most one plaque in \overline{U}_β . Every foliated atlas has a coherent refinement that is regular.

In the case of a codimension-1 foliation \mathcal{F} on a connected manifold M there exists always a 1-dimensional C^∞ -foliation \mathcal{L} transverse to \mathcal{F} and a foliated atlas $\mathfrak{U} = \{U_\alpha, \phi_\alpha\}$ such that it is simultaneously a regular foliated atlas for both foliations \mathcal{F} and \mathcal{L} . The \mathcal{F} -plaques are the level sets of $\text{pr}_2 \circ \phi_\alpha$ and the \mathcal{L} -plaques are the level sets of $\text{pr}_1 \circ \phi_\alpha$. Such a foliated atlas is called a *biregular cover* and will be used in the proofs below. Following [CC00] a foliation \mathcal{F} on a compact manifold M is said to be of class $C^{1,0+}$ if M has a differentiable structure relative to which each leaf is C^1 -immersed and the resulting inclusion $T\mathcal{F} \rightarrow TM$ imbeds $T\mathcal{F}$ as a C^0 -plane subbundle of TM .

Remark 1.1. *We assume a compact center foliation \mathcal{W}^c and accordingly, every center leaf is an embedded C^1 -manifold in M . The center bundle E^c is a continuous subbundle of TM as a consequence of the definition of partial hyperbolicity. Hence, the center foliation is a $C^{1,0+}$ -foliation.*

Example 1.2 (Torus foliation). *Let $X = \begin{bmatrix} a \\ b \end{bmatrix}$ be a linear vector field on \mathbb{R}^2 with $a, b \in \mathbb{R}$ and $a \neq 0$. Since it is invariant under all translations in \mathbb{R}^2 it passes to a well-defined vector field on the 2-torus $\mathbb{T}^2 = \mathbb{R}^2/\mathbb{Z}^2$. The orbits of this vector field X in \mathbb{R}^2 are lines $\left\{ \begin{bmatrix} at + a_0 \\ bt + b_0 \end{bmatrix} \mid t \in \mathbb{R} \right\}$ with starting point $\begin{bmatrix} a_0 \\ b_0 \end{bmatrix} \in \mathbb{R}^2$. They pass to a well-defined one-dimensional foliation $y(x) = \frac{b}{a}x + c$ with constant $c = b_0 - \frac{a_0}{a}$ on \mathbb{T}^2 . The one-dimensional leaves are closed and diffeomorphic to circles if and only if the slope $\frac{b}{a}$ of the lines is rational. Otherwise, every leaf is a one-to-one immersion of \mathbb{R} and lies densely in \mathbb{T}^2 .*

The 2-torus \mathbb{T}^2 is the only oriented compact surface which admits a one-dimensional foliation. More generally, a closed n -dimensional manifold admits a one-dimensional foliation if and only if its Euler characteristic is zero.

1.1. Compact foliations and homeomorphism groups

Example 1.3 (Flat bundle foliation). *Consider the group $G = \mathbb{Z}_2$ acting on $\mathbb{T}^2 \times \mathbb{S}^1$ by $(x, \theta) \mapsto (-x, \theta + \frac{1}{2})$ without fixed points. Then the quotient $\mathbb{T}^2 \times \mathbb{S}^1 / \mathbb{Z}_2$ is a compact manifold, called mapping torus by $-\text{id}$. The product foliation $\mathcal{F} := \{\{x\} \times \mathbb{S}^1\}_{x \in \mathbb{T}^2}$ is invariant under the group action and passes to a well-defined foliation \mathcal{F}/\mathbb{Z}_2 on the mapping torus $\mathbb{T}^2 \times \mathbb{S}^1 / \mathbb{Z}_2$.*

This concept can be generalized in the following way: Let G be a group acting freely and properly discontinuously on a connected manifold \tilde{M} . Then \tilde{M}/G is a compact manifold. Let G act from the left on a manifold F . Then $E := \tilde{M} \times_G F = \tilde{M} \times F / (yg, z) \sim (y, gz)$ is a manifold. Every G -invariant foliation \mathcal{F} , especially the product foliation $\mathcal{F} = \{\tilde{M} \times \{x\}\}_{x \in F}$, passes to a well-defined foliation $\mathcal{F}_G = \mathcal{F}/G$ on the quotient E .

Example 1.4 (Seifert bundle). *The Example 1.3 above of the foliation by circles on $\mathbb{T}^2 \times \mathbb{S}^1 / \mathbb{Z}_2$ is an example of a Seifert bundle. A Seifert bundle M is a closed 3-dimensional manifold which decomposes into a pairwise disjoint union of circles, called fibers, such that every circle has a neighborhood (fiber-preserving) homeomorphic to a standard fibered torus. A standard fibered torus is the following: Consider the product $D \times I$ of a 2-dimensional disk D and the unit interval I and a homeomorphism $\rho : D \rightarrow D$ which rotates D by the angle $2\pi \frac{a}{b}$. The map ρ is completely determined by the rational number $\frac{a}{b} \bmod 1$. Then we obtain a standard fibered torus if we identify $(x, 0)$ with $(\rho(x), 1)$ for every $x \in D$. If $a = 0$, then this fiber is called ordinary, otherwise exceptional. A Seifert bundle is therefore a circle bundle $p : M \rightarrow B$ over a two-dimensional orbifold B . We call a topological space a 2-dimensional orbifold if it is locally homeomorphic to the quotient space \mathbb{R}^2/Γ of \mathbb{R}^2 by a linear action of a finite group Γ . The base space B is not a manifold but an orbifold if the Seifert bundle has exceptional fibers. Every exceptional fiber corresponds to a singular point on B , i.e. a point whose neighborhood is homeomorphic to \mathbb{R}^2/Γ and Γ is a finite, non-trivial group. In the example above, there are 4 exceptional fibers corresponding to the fixed points of the action of \mathbb{Z}_2 on \mathbb{T}^2 . This example reappears in the context of partially hyperbolic diffeomorphisms as the Seifert bundle $\mathbb{T}^2 \times \mathbb{S}^1 / \mathbb{Z}_2$ admits a partially hyperbolic diffeomorphism.*

Example 1.5 (Foliation on the unit tangent bundle of a hyperbolic surface). *Let Σ_g be any surface of genus g with constant negative curvature -1 . Any hyperbolic surface can be represented as quotient $\Sigma_g = \mathbb{H}^2 / \pi_1(\Sigma_g)$ of the hyperbolic plane \mathbb{H}^2 and the fundamental group $\pi_1(\Sigma_g)$ which is a discrete subgroup of $\text{PSL}(2, \mathbb{R})$. The unit tangent bundle $T^1 \Sigma_g \cong \mathbb{H}^2 \times \mathbb{S}^1 / \pi_1(\Sigma_g)$ can be identified with $\text{PSL}(2, \mathbb{R}) / \pi_1(\Sigma_g)$. Define a foliation by the left cosets*

$\{gH\}_{g \in \text{PSL}(2, \mathbb{R})}$ of the subgroup

$$H = \left\{ \begin{pmatrix} a & b \\ 0 & a^{-1} \end{pmatrix} \mid a > 0 \right\} < \text{PSL}(2, \mathbb{R})$$

on $\mathbb{H}^2 \times \mathbb{S}^1$. Then the foliation is invariant under left translations and passes to a quotient foliation on the bundle $T^1\Sigma_g = \mathbb{H}^2 \times \mathbb{S}^1 / \pi_1(\Sigma_g)$.

Holonomy. It is possible to define a foliation in an equivalent way with the help of holonomy cocycles: Let $\text{pr} : \mathbb{R}^n = \mathbb{R}^{n-q} \times \mathbb{R}^q \rightarrow \mathbb{R}^q$ be the canonical projection onto the last q coordinates. Let $(U_\alpha, \phi_\alpha), (U_\beta, \phi_\beta)$ be two foliated charts with $U_\alpha \cap U_\beta \neq \emptyset$ and denote by $y_\alpha : U_\alpha \rightarrow B^q$ the submersion $\text{pr} \circ \phi_\alpha$. We can identify any set $y_\alpha(U_\alpha) \subset \mathbb{R}^q$ with a q -dimensional smooth manifold $T_\alpha \hookrightarrow U_\alpha$ transverse to the foliation \mathcal{F} . Then a foliation \mathcal{F} of codimension q is given by a regular foliated atlas $\{(U_\alpha, \phi_\alpha)\}_{\alpha \in \mathfrak{A}}$ of class C^r , submersions $y_\alpha : U_\alpha \rightarrow T_\alpha$ over a transverse q -dimensional manifold T_α and for any U_α, U_β with $U_\alpha \cap U_\beta \neq \emptyset$ a C^r -diffeomorphism

$$\begin{aligned} c_{\alpha\beta} : y_\alpha(U_\alpha \cap U_\beta) &\rightarrow y_\beta(U_\alpha \cap U_\beta), \text{ such that} \\ y_\beta(x) &= c_{\alpha\beta} \circ y_\alpha(x) \quad \text{for all } x \in U_\alpha \cap U_\beta. \end{aligned}$$

The cocycle $\{c_{\alpha\beta}\}_{\alpha, \beta \in \mathfrak{A}}$ is called *holonomy cocycle*. Each map $c_{\alpha\beta}$ is a C^r -diffeomorphism, $0 \leq r \leq \infty$, from $y_\alpha(U_\alpha \cap U_\beta) \subset T_\alpha$ onto $y_\beta(U_\alpha \cap U_\beta) \subset T_\beta$. A point $z \in T_\alpha$ lies inside the domain of $c_{\alpha\beta}$ if and only if the plaque $P_z \subset U_\alpha$ through z intersects a unique plaque $P_w \subset U_\beta$ with $w \in T_\beta$, and it is $c_{\alpha\beta}(z) = w$. If γ is a path contained in $P_z \cup P_w$ from z to w we can define the *holonomy* of this path to be

$$H_\gamma = c_{\alpha\beta} : y_\alpha(U_\alpha \cap U_\beta) \rightarrow y_\beta(U_\alpha \cap U_\beta),$$

hence, it is a map from an open set $U \subset T_\alpha$ to an open set $V \subset T_\beta$. The concept of holonomy, initiated by ideas of Reeb and formally introduced by Ehresmann in 1950, is central in foliation theory and essential to understanding the behavior of a foliation nearby one leaf. It describes - following a closed path $\gamma(t)$ inside one leaf for $t \rightarrow \infty$ - how nearby leaves behave dynamically, if - for example - more and more leaves spiral into view or out of view or if every leaf stays more or less parallel. We now define the notion of holonomy:

We fix a regular foliated atlas \mathfrak{A} . The union $T := \bigcup_{\alpha \in \mathfrak{A}} T_\alpha$ of all embedded transverse manifolds T_α is itself an embedded q -dimensional manifold, transverse to the foliation \mathcal{F} (cp. [CC00, p.57]). We consider a closed path $\gamma : [0, 1] \rightarrow F(x)$ with $\gamma(0) = x$ which lies entirely inside one leaf

1.1. Compact foliations and homeomorphism groups

$F(x)$. Then we can find a chain of plaques $\{P_0, \dots, P_m\}$ with $P_m = P_0$ and $P_i \cap P_{i+1} \neq \emptyset$ for all $0 \leq i \leq m-1$ and $P_i \subset U_{\alpha_i}$ and a suitable subdivision $0 = t_0 < \dots < t_{m+1} = 1$ such that $\gamma([t_i, t_{i+1}]) \subset P_i$ for $i = 0, \dots, m$. We set

$$H_\gamma = c_{\alpha_m \alpha_{m-1}} \circ \dots \circ c_{\alpha_1 \alpha_0}$$

and call this diffeomorphism H_γ the *holonomy homeomorphism along the path* γ . The point $x = \gamma(0)$ is fixed by H_γ . To obtain a well-defined notion we have to take the germ of H_γ which we denote for simplicity with H_γ again. The definition of H_γ is then independent from the choice of the plaque chain and the subdivision. Further, it does only depend on the homotopy class $[\gamma]$ of γ . Hence, we obtain a group homomorphism

$$\pi_1(F(x), x) \rightarrow \text{Homeo}(\mathbb{R}^q, 0).$$

The image of this group homomorphism is called the *holonomy group* of the leaf $F(x)$ and denoted by $\text{Hol}(F(x), x)$. It is a subgroup of all germs of homeomorphisms of \mathbb{R}^q which fixes the origin. By taking the isomorphism class of this group it does not depend on the original embedding of T in M . It is easily seen that any simply connected leaf has a trivial holonomy group. We say that a foliation has *finite holonomy* if the holonomy group $\text{Hol}(F(x), x)$ for any $x \in M$ is a finite group. This is the main object we consider in the following.

For completeness, we mention that we obtain a global notion of holonomy, the so-called *holonomy pseudogroup*, by taking the set of all groups

$$\{H_\gamma \mid \gamma \text{ is a path from } y \text{ to } z \text{ inside a leaf } L\}$$

for all $y, z \in T$ inside a common leaf L consisting of the homeomorphisms $H_\gamma : T \rightarrow T$. It fails to be a group because any holonomy map is only defined locally on T and not globally, so not any composition of holonomy maps may be defined. This pseudogroup depends on the choice of foliated atlas but any two holonomy pseudogroups induced by two regular foliated atlases are equivalent. So, by taking the equivalence class of a holonomy pseudogroup we have the *holonomy groupoid*.¹

Compact leaves with finite holonomy. In codimension one (also on a non-compact manifold) it is shown by Reeb in [Ree52] and in codimension two on compact manifolds by Epstein in [Eps72], that any compact foliation has finite holonomy. But in higher codimension there exist counterexamples:

¹A *groupoid* \mathcal{G} on a set X is a category with inverses, having X as its set of objects. In the case of a holonomy groupoid the transversal T is the set of objects.

Sullivan constructed in [Sul76a] and [Sul76b] a flow on a compact 5-manifold such that every orbit is periodic but the length of orbits is unbounded. Later, Epstein and Vogt in [EV78] constructed an example with the same properties on a compact 4-manifold. In the following we will therefore assume a compact center foliation with finite holonomy (if the codimension is greater than 2).

We cannot assume that our foliations are smooth in transverse direction, so we only obtain a continuous holonomy cocycle and thus a holonomy group which is a subgroup of a homeomorphism group. Usually in foliation theory, higher smoothness is required such that the homeomorphism group above turns into a diffeomorphism group $\text{Diff}^r(\mathbb{R}^q, 0)$ which acts differentiably on the transverse manifold and consequently, it has nicer properties. Especially in the case of a finite holonomy group, it is equivalent to a linear action. A lot of difficulties which arise during our proofs below have their offspring in this fact that we do not deal with a foliation which varies smoothly in transverse direction, but only continuously.

In the special case that the foliated manifold (M, \mathcal{F}) is a *foliated bundle*, that is if there exists a smooth manifold B such that $p : M \rightarrow B$ is a fiber bundle with q -dimensional fiber, the foliation \mathcal{F} is transverse to the fibers $\{p^{-1}(x)\}_{x \in B}$ and p restricted to a leaf $F \in \mathcal{F}$ is a covering map, the holonomy groupoid of \mathcal{F} is actually a group, called the total holonomy group defined by a group homomorphism $\pi_1(B, x) \rightarrow \text{Diff}^r(p^{-1}(x))$ which determines the foliation. Hence, in this particular case, if the foliation is smooth and the holonomy group a finite group, the leaf space M/\mathcal{F} , obtained by identifying the points of a leaf, can be locally identified with the quotient of \mathbb{R}^q by a linear action of the finite holonomy group, thus, with an orbifold (cp. Theorem 2.15 by Moerdijk and Mrcun in [MM03]).

The reason why we restrict ourselves to compact foliations with finite holonomy is closely related to the point that under these assumptions there exist small saturated neighborhoods $V(L)$ of any leaf L that are foliated bundles $p : V(L) \rightarrow L$ and the holonomy group is a group. This fact is the content of the Reeb Stability Theorem which is proved in the present form in [CC00]:

Theorem 1.6 (Generalized Reeb Stability). *If L is a compact leaf of a $C^{1,0+}$ -foliated manifold (M, \mathcal{F}) and if the holonomy group $\text{Hol}(L, y)$ is finite, then there is a normal neighborhood $p : V \rightarrow L$ of L in M such that $(V, \mathcal{F}|_V, p)$ is a foliated bundle with all leaves compact. Furthermore, each leaf $L'|_V$ is a covering space $p|_{L'} : L' \rightarrow L$ with $k \leq |\text{Hol}(L, y)|$ sheets and the leaf L' has a finite holonomy group of order $\frac{|\text{Hol}(L, y)|}{k}$.*

Consequently, the leaf space of such a neighborhood is homeomorphic to $T/\text{Hol}(F(x), x)$, where T is a smooth embedded manifold transverse to the

1.1. Compact foliations and homeomorphism groups

leaf $F(x)$, and looks more or less like an orbifold, and in the special case of a trivial holonomy group, it is just homeomorphic to T .

We call property of a foliation \mathcal{F} *generic* if a \mathcal{F} -saturated set that is contained in a countable intersection of open and dense subsets has this property. Hector in [Hec77] and Epstein, Millet and Tischler in [EMT77] proved that having trivial holonomy is a generic property:

Theorem 1.7. *Let (M, \mathcal{F}) be a foliated manifold. The leaves of \mathcal{F} having trivial holonomy group are generic, i.e. their union is a residual, \mathcal{F} -saturated set.*

A further reason why we assume a compact foliation with finite holonomy is that also globally the leaf space is quite well-behaved, as it is a Hausdorff space. The canonical quotient map $\pi : M \rightarrow M/\mathcal{W}^c$ is continuous with respect to the quotient topology. It is always open, because the set of leaves meeting an open set is open for every foliation (cp. [CC00]). If the foliation is compact, then the leaf space is Hausdorff if and only if the holonomy group on every leaf is finite as it is shown by Epstein in [Eps76]:

Theorem 1.8. *Let M be a foliated space with each leaf compact. Then the following conditions are equivalent:*

- *The quotient map $\pi : M \rightarrow M/\mathcal{F}$ is closed.*
- *π maps compact sets to closed sets.*
- *Each leaf has arbitrarily small saturated neighborhoods.*
- *The leaf space M/\mathcal{F} is Hausdorff.*
- *If $K \subset M$ is compact then the saturation $\pi^{-1}\pi K$ of K is compact, this means, the set of leaves meeting a compact set is compact.*
- *The holonomy group on every leaf is finite.*

Notation: We introduce the following notation for a \mathcal{F} -saturated open ball of Hausdorff radius $\delta > 0$:

$$B_H(F(x), \delta) := \{F(y) \subset M \mid d_H(F(x), F(y)) < \delta\}.$$

We need the following small Lemma which holds under the assumption of a compact foliation with finite holonomy and which is closely related to the content of Epstein's Theorem 1.8 above that the leaf space is a Hausdorff space and equivalently, there exists a basis of small saturated neighborhoods:

Lemma 1.9. *Let \mathcal{F} be a compact foliation of a compact manifold M with finite holonomy. Then for given $\alpha > 0$ and $x \in M$ there exists $\epsilon > 0$ such that the \mathcal{F} -saturate $\mathcal{F}(B(x, \epsilon)) = \bigcup_{y \in B(x, \epsilon)} F(y)$ of an ϵ -ball $B(x, \epsilon)$ is contained in a \mathcal{F} -saturated neighborhood $B_H(F(x), \alpha)$ of $F(x)$, i.e.*

$$\mathcal{F}(B(x, \epsilon)) \subset B_H(F(x), \alpha).$$

Proof. Assume it is not the case. Then there exists a sequence $\epsilon_n > 0$ such that $\epsilon_n \rightarrow 0$. With the Reeb Stability Theorem 1.6 we can find a sequence $F(y_n) \in \mathcal{F}(B(x, \epsilon_n))$ such that $d_H(F(x), F(y_n)) \geq \alpha$. The leaf space M/\mathcal{F} is a Hausdorff space as the center foliation is compact with finite holonomy, hence it is $F(y_n) \rightarrow F(y) \in \bigcap_{n \geq 0} \mathcal{F}(B(x, \epsilon_n)) = F(x)$. Therefore $d_H(F(x), F(y_n)) \rightarrow 0$ and this is a contradiction. \square

Further properties of the leaf space are discussed in the subsequent section 1.3. The following implication is quite useful and proved by Millet in [Mil75]:

Corollary 1.10. *Let M be a compact smooth manifold and \mathcal{F} a compact codimension- q foliation on M with finite holonomy and $\phi : D^q \rightarrow M$ a smooth embedding of the q -dimensional disk $D^q \subset \mathbb{R}^q$ such that $\phi(D^q)$ is transverse to \mathcal{F} and $\phi(0) = x$. Then there exists $\epsilon > 0$ such that*

$$\sharp \{ \phi(\epsilon D^q) \cap F(y) \} < \infty$$

for every $y \in \phi(\epsilon D^q)$.

Example 1.11 (Torus foliation). *The one-dimensional foliation on the torus \mathbb{T}^2 in Example 1.2 illustrates trivial holonomy in the case of a compact and non-compact foliation. If the slope $\frac{b}{a}$ is rational then every leaf is compact and homeomorphic to \mathbb{S}^1 . Every leaf is parallel to each other and has the same period, hence, the holonomy is trivial. The leaf space generated by identifying all points on a common leaf is homeomorphic to \mathbb{S}^1 and hence, it is a compact manifold. The quotient map $\pi : \mathbb{T}^2 \rightarrow \mathbb{S}^1$ defines a fiber bundle and the fibers are exactly the leaves of the foliations.*

Otherwise, if the slope $\frac{b}{a}$ is irrational every leaf is homeomorphic to \mathbb{R} and hence, it is simply connected. Every holonomy group is trivial. Nevertheless, the leaf space is not Hausdorff because the leaves are not compact: As every leaf is dense in \mathbb{T}^2 it cannot be separated from another leaf by any open neighborhood. The only open sets in the leaf space are the whole space and the empty set.

Example 1.12 (Flat bundle foliation). *In the case of a flat bundle foliation of the manifold $\tilde{M} \times_G F$ as described in Example 1.3 the holonomy group of every leaf $\mathcal{F}_x = \tilde{M} \times_G \{x\}$ is the isotropy group $G_x = \{g \in G \mid gx = x\}$ of G of the point $x \in F$. The leaf space is just F/G , every neighborhood in F/G of x is homeomorphic to \mathbb{R}^q/G_x where $q = \text{codim } F$.*

In the concrete example of the foliation by circles of the mapping torus $M = \mathbb{T}^2 \times \mathbb{S}^1/\mathbb{Z}_2$ every leaf $\{x\} \times \mathbb{S}^1/\mathbb{Z}_2$ with $x \in \mathbb{T}^2$ has trivial holonomy except if x is a fixed point of the action of \mathbb{Z}_2 on \mathbb{T}^2 , i.e. if $x = (0, 0), x = (0, \frac{1}{2}), x = (\frac{1}{2}, 0)$ or $x = (\frac{1}{2}, \frac{1}{2})$. The holonomy group of these four leaves is isomorphic to \mathbb{Z}_2 .

Homeomorphism groups. We assume that the holonomy group of any center leaf is a finite group, unless in the case of a codimension-2 center foliation where it is implied by the compactness of the foliation. Consequently, if $\text{Hol}(F(x), x)$ is a finite group acting on a sufficiently small embedded manifold T transverse to $F(x)$ at x , then - using Corollary 1.10 - any leaf $F(y)$ with $y \in T$ intersects the manifold T in only finitely many points, hence any holonomy homeomorphism $H : T \rightarrow T$ interchanges these intersection points and is therefore periodic in this point with a period k depending on y . Due to a theorem by Montgomery in [Mon37] any pointwise periodic homeomorphism on a connected metric space is periodic, and therefore we deal with a group of periodic homeomorphisms as holonomy homeomorphisms. The holonomy group $\text{Hol}(F(x), x)$ acts continuously on the smooth manifold T transverse to $F(x)$ in the canonical way by $(x, H) \in T \times \text{Hol}(F(x), x) \mapsto H(x) \in T$. Topological groups acting continuously on a topological space are known as transformation groups. Therefore, we can find some useful results on the fixed point sets of such homeomorphisms of the theory of finite transformation groups which we need and cite here. First, it is quite obvious that any non-trivial homeomorphism of $(-1, 1) \rightarrow (-1, 1)$ which leaves the origin fixed reverses the orientation.

Lemma 1.13. *Let $\text{Homeo}((-1, 1), 0)$ be the group of germs at $0 \in \mathbb{R}$ of homeomorphisms which leave $0 \in \mathbb{R}$ fixed. Let G be a finite subgroup of $\text{Homeo}((-1, 1), 0)$. Then G has at most 2 elements. If G has 2 elements, then one of them reverses orientation.*

Proof. Let $\hat{f} \in G$ be represented by a homeomorphism $f : (-1, 1) \rightarrow \mathbb{R}$ with $f(0) = 0$. As G is a finite group we can choose f so that $f^k = \text{id}$ for some integer $k \geq 1$. Assume f is orientation-preserving and $f \neq \text{id}$ then we can find $t \geq 0$ such that $0 < f(t) < t$. This implies $f^k(t) < f^{k-1}(t) < \dots < t$ contradicting $f^k = \text{id}$. Thus G is the

trivial group if every element is orientation-preserving. If f is orientation-reversing then f^2 is orientation-preserving and the same argument can be applied. Thus $f^2 = \text{id}$ is implied and G has at most two elements. \square

The following theorem describes the fixed point set of periodic homeomorphisms of the two-dimensional disk $\mathbb{D}^2 \subset \mathbb{R}^2$. It was published by Kerékjártó in [vK19] and Brouwer in [Bro19] at the same time in the same journal, but completely proven 15 years later by Eilenberg in [Eil34]. The proof is rewritten in modern mathematical language in [CK94].

Theorem 1.14 (Theorem of Kerékjártó). *Suppose $g : \mathbb{D}^2 \rightarrow \mathbb{D}^2$ is a periodic homeomorphism of period $n > 1$. Then g is topologically conjugate to a orthogonal matrix $A \in O(2)$, i.e. there is a homeomorphism h such that $g = h^{-1}Ah$. If g is orientation-preserving, the set of fixed points is a single point which is not on the boundary. If g is orientation-reversing, then $g^2 = \text{id}$ and the set of fixed points is a simple arc which divides \mathbb{D}^2 into two topological discs which are permuted by g .*

Any periodic homeomorphism on the two-dimensional disk is topologically conjugate to either a finite order rotation around the origin or the reflection about the x -axis. We will need that any periodic homeomorphism on a open disk is conjugate to a finite order rotation around the origin or to a reflection. This is a consequence of the Theorem of Kerékjártó proved in [CK94]:

Corollary 1.15. *Let $f : \mathbb{R}^2 \rightarrow \mathbb{R}^2$ be a periodic homeomorphism. Then f is conjugate to a finite order rotation around the origin or to the reflection about the x -axis.*

Unfortunately, equivalent statements in higher dimensions are only available in the case of a differentiable effective group action of a compact group on a differentiable manifold where it was shown by Bochner in [Boc45] that there exists a smooth change of coordinates in a neighborhood of a common fixed point of the group action such that in the new coordinates all transformations are linear. In the case of a finite holonomy group of diffeomorphisms we can conclude that it acts linearly on the transversal. In the 1940s, it was conjectured that any periodic homeomorphism of the n -sphere or the n -dimensional euclidean space is topologically conjugate to a product of rotations and reflections. But Bing constructed in [Bin52] a counterexample of a 2-periodic homeomorphism of the 3-dimensional euclidean space. Montgomery and Zippin modifies in [MZ54] this idea to the example of a circle group acting on a four-dimensional euclidean space so the action cannot be differentiable in any differentiable structure of the space and therefore definitely not equivalent to a linear group action. Hence, although the finite

holonomy group may be isomorphic as a group to a subgroup of the orthogonal group, we cannot expect a priori that it acts linearly on the transversely embedded manifold. At least, we can use the following theorem by Newman in [New31] about the fixed point set of a periodic homeomorphism which is especially helpful as it holds in any dimension:

Theorem 1.16. *Let M_n be a n -dimensional connected manifold and $g : M_n \rightarrow M_n$ a periodic homeomorphism. If the set of fixed points of g has a non-empty interior, then g is the identity map on M_n .*

1.2 Partially hyperbolic systems

1.2.1 Definitions and basic properties

Let M be a compact connected smooth n -dimensional Riemannian manifold without boundary. A C^1 -diffeomorphism $f : M \rightarrow M$ is called (*pointwise*) *partially hyperbolic* if there exists an invariant, non-trivial decomposition of the tangent bundle

$$TM = E^s \oplus E^c \oplus E^u, \quad d_x f E^\alpha(x) = E^\alpha(f(x)), \quad \alpha = s, c, u,$$

and if there exist continuous functions $\lambda, \gamma_1, \gamma_2, \mu : M \rightarrow \mathbb{R}$ such that it holds for every $x \in M$

$$0 < \lambda(x) < \gamma_1(x) \leq 1 \leq \gamma_2(x) < \mu(x)$$

and

$$\begin{aligned} \|d_x f(v)\| &\leq \lambda(x), & v \in E^s(x), \|v\| &= 1, \\ \gamma_1(x) \leq \|d_x f(v)\| &\leq \gamma_2(x), & v \in E^c(x), \|v\| &= 1, \\ \mu(x) \leq \|d_x f(v)\|, & & v \in E^u(x), \|v\| &= 1. \end{aligned}$$

Remark 1.17. *The classical definition uses f^n instead of f but Gourmelon showed in [Gou07] that we can choose a metric, equivalent to the original one, such that we can use f directly.*

Remark 1.18. *In the following we always assume that every subbundle E^s, E^u and E^c is non-trivial.*

In comparison with a hyperbolic diffeomorphism there exists a center subbundle E^c such that any vector in E^c is neither contracted by df as strongly as any non-zero vector in E^s nor expanded as strongly as any non-zero vector in E^u . The invariance and the growth rates of the subbundles above

imply that the subbundles are continuous, that is, the angle between $E^\alpha(x)$ and $E^\alpha(y)$ varies continuously with respect to the distance of $x, y \in M$ for $\alpha = s, c, u$.

Partial hyperbolicity is a C^1 -open property, i.e. every diffeomorphism g sufficiently close with respect to the C^1 -topology to a partially hyperbolic diffeomorphism f is also partially hyperbolic. But in opposite to hyperbolic diffeomorphism they are usually not structurally stable and two diffeomorphisms, although C^1 -close, can exhibit quite different dynamical behavior. The following three examples represent three important classes of examples which are extensively studied. Every example of them stands for a class of partially hyperbolic systems because we get an open set of partially hyperbolic systems by perturbing every example.

Example 1.19 (Toral automorphism). *The simplest case of a partially hyperbolic system is perhaps the action of a linear map $A \in \mathrm{SL}(n, \mathbb{Z})$ on the torus \mathbb{T}^n whose spectrum splits into three disjoint annuli corresponding to the stable, unstable and center bundle. The center leaves of such a partially hyperbolic system are typically non-compact and dense.*

Example 1.20 (Skew product). *Let $f : M \rightarrow M$ be an Anosov diffeomorphism and $\phi : M \rightarrow G$ a smooth map into a compact Lie group G . Then the skew product $f_\phi(x, g) = (f(x), \phi(x)g)$ is partially hyperbolic where the center bundle is the tangent bundle of G . In this class of examples, the center is integrable and every center leaf $\{x\} \times G$ is compact. An easy special case of a skew product is obtained by choosing $\phi \equiv h \in G$. The result is a direct product $f \times (hg)$ of an Anosov and a constant rotation in G .*

Example 1.21 (Generalization of skew products). *More generally, corresponding to the generalizations in Example 1.3, we have the following class of examples: If a group G acts properly discontinuously and freely as a product action on a compact connected manifold $M \times F$, then*

$M \times_G F = M \times F / (gx, gy) \sim (x, y)$ is a compact manifold. Let $f_\phi : M \times F \rightarrow M \times F$ defined by $f_\phi(x, y) = (f(x), \phi(x)(y))$ be a partially hyperbolic skew product with a smooth map $\phi : M \rightarrow \mathrm{Diff}(F)$. Assume that f_ϕ is G -equivariant, i.e. $f_\phi(gx, gy) = gf_\phi(x, y)$ for all $g \in G$ and $(x, y) \in M \times F$, and its center foliation $\mathcal{W}^c = \{\{x\} \times F\}_{x \in M}$ is G -invariant, i.e. $G\mathcal{W}^c = \mathcal{W}^c$. Then the partially hyperbolic diffeomorphism f_ϕ descends to a partially hyperbolic diffeomorphism $f_{\phi, G} : M \times_G F \rightarrow M \times_G F$ with a compact center foliation given by $\mathcal{W}_G^c := \{W^c(x) / (x \sim gx)\} = \{\{x\} \times F\}_{x \sim gx}$. The holonomy group of $W_G^c(x)$ is exactly the isotropy group G_x of $x \in M$ of the action of G on M . This principle is a good way to construct examples with non-trivial center holonomy.

Example 1.22 (Time-1 map of Anosov flow). *An example which has been classically studied in the dynamical systems is the time- t map of an Anosov flow. Let $\phi_t : M \rightarrow M$ be an Anosov flow of a compact Riemannian manifold. For every $t \neq 0$ the diffeomorphism ϕ_t is partially hyperbolic with the one-dimensional center subbundle $\langle \dot{\phi} \rangle$ generated by the vector field $\dot{\phi}$. Therefore, the center bundle is integrable to a one-dimensional foliation with typically compact and non-compact leaves corresponding to periodic and non-periodic solutions of the vector field.*

A geodesic flow on the unit tangent bundle of a negatively curved manifold is an example for an Anosov flow. A simpler case is the case when the manifold is a surface with curvature -1 : Let Σ_g be any compact surface of genus g with constant negative curvature -1 . Recalling Example 1.5 any hyperbolic surface can be identified with a quotient \mathbb{H}^2/Γ of the hyperbolic plane where $\Gamma < \mathrm{PSL}(2, \mathbb{R})$ is a discrete subgroup and isomorphic to the fundamental group $\pi_1(\Sigma_g)$. Therefore, the unit tangent bundle $T^1\Sigma_g = \mathbb{H}^2 \times \mathbb{S}^1/\Gamma$ is homeomorphic to $\mathrm{PSL}(2, \mathbb{R})/\Gamma \cong T_v^1\Sigma_g$ if one point $v \in \mathbb{H}^2$ is fixed. The geodesic flow ϕ on $T^1\Sigma_g$ is just a left translation of a subgroup $H < \mathrm{PSL}(2, \mathbb{R})$ on the homogeneous space $\mathrm{PSL}(2, \mathbb{R})/\Gamma$. The time-1 map is partially hyperbolic. Its center bundle is given by the vector bundle $\langle \dot{\phi} \rangle$ and the center foliation is identical to the left cosets $\{gH\}_{g \in \mathrm{PSL}(2, \mathbb{R})}$ modulo Γ .

Integrability of the stable and unstable subbundles. Given a partially hyperbolic diffeomorphism f , none of the three subbundles E^s, E^c and E^u is smooth such that the Frobenius theorem could be applied directly to show the integrability of them. A subbundle $E \subset TM$ is called *integrable* if there exists a foliation \mathcal{F} such that for all $x \in M$ the leaf $F(x) \in \mathcal{F}$ through x is a C^1 -manifold everywhere tangent to $E(x)$. The subbundle E is called *uniquely integrable* if E is integrable with an integral foliation \mathcal{F} , and in addition any C^1 -path everywhere tangent to E lies in a single leaf of the integral foliation \mathcal{F} . In the case of the strong stable and strong unstable bundle E^s and E^u the growth rates and the df -invariance can be used to show with the method of Hadamard-Perron that the stable and unstable bundle E^s and E^u are uniquely integrable to the stable and unstable foliation \mathcal{W}^s and \mathcal{W}^u . The leaves of both foliations \mathcal{W}^s and \mathcal{W}^u are as smooth as the diffeomorphism f . Hence, in our case all stable and unstable leaves are C^1 -manifolds. The integrability of E^s and E^u is a result by Hirsch, Pugh and Shub in [HPS70] and Brin and Pesin in [BP74].

Integrability of the center bundle. One of the problems in studying partially hyperbolic diffeomorphisms is related to the question which condi-

tions imply the integrability of the center bundle E^c . There exist examples for a non-integrable center bundle by Wilkinson in [Wil98], where the non-integrability is not caused by a lack of differentiability of E^c , but because E^c does not satisfy the conditions of the Frobenius theorem. Assuming a smooth center bundle E^c , a so called bunching condition on the growth rates of f implies the integrability of the center bundle as it is shown by Burns and Wilkinson in [BW05b]. Brin, Burago and Ivanov in [BBI04] developed in this context the concept of weak integrability. We say that a subbundle $E \subset TM$ is *weakly integrable* if for each point $x \in M$ there is an immersed complete C^1 -manifold $W(x)$ with $x \in W(x)$ and $T_y W(x) = E(y)$ for every $y \in W(x)$. But the integral manifolds $W(x)$ may not form a partition of M and may be self-intersecting. Brin, Burago and Ivanov showed that the center-stable bundle $E^c \oplus E^s$, the center-unstable bundle $E^c \oplus E^u$ and the center bundle E^c are weakly integrable, if the center bundle is one-dimensional. In the case of a smooth center bundle both concepts of weak integrability and integrability coincide.

In general, the center bundle E^c may not be (even weakly) integrable. There exists an example by Rodriguez-Hertz, Rodriguez-Hertz and Ures in [HRHU10] of a partially hyperbolic diffeomorphism on the 3-torus with an integrable center bundle which is not uniquely integrable.

We assume that there exists a f -invariant center foliation $\mathcal{W}^c = \{W^c(x)\}_{x \in M}$ everywhere tangent to the center bundle E^c . We do neither require that this foliation \mathcal{W}^c is unique nor that the center bundle E^c is uniquely integrable. It is not known (following the summary in [BW08]) if the existence of a unique integral foliation tangent to E^c implies that the bundle E^c is uniquely integrable. We remark, that generally the existence of a unique integral foliation tangent to a subbundle E is strictly weaker than the unique integrability of a subbundle E . There exists an example described in [BW08] of a 1-dimensional subbundle $E \subset \mathbb{R}^2$ with a unique integral foliation, but there exists a C^1 -path everywhere tangent to E which is not contained in a single leaf of the integral foliation, and therefore E is not uniquely integrable.

Although there exist three foliations tangent to the center, unstable and stable bundle respectively it is not clear that there exists a center-unstable foliation tangent to the center-unstable bundle $E^{cu} := E^c \oplus E^u$. The only candidate $\bigcup_{y \in W^c(x)} W^u(y)$ for a center-unstable manifold tangent to E^{cu} is constructed by taking the union of all unstable manifolds through the center manifold $W^c(x)$. A priori it could happen that not every center leaf $W^c(z)$ through a unstable leaf $W^u(y)$ with $y \in W^c(x)$ is wholly contained in the set $\bigcup_{y \in W^c(x)} W^u(y)$. So there may be a partially hyperbolic diffeomorphism with an integrable center bundle whose center-unstable and center-stable bundle are not integrable. An example is constructed in [HRHU10]. This gives rise

to the definition of the following property: A partially hyperbolic diffeomorphism f is called *dynamically coherent*, if there exist a center-stable foliation \mathcal{W}^{cs} tangent to $E^{cs} = E^s \oplus E^c$ and a center-unstable foliation \mathcal{W}^{cu} tangent to $E^{cu} = E^c \oplus E^u$.

Dynamical coherence does not require unique integrability of E^{cs} or E^{cu} or the invariance of the corresponding center-stable and center-unstable foliations. The existence of both foliations implies the existence of a center foliation tangent to E^c and that the center-stable foliation \mathcal{W}^{cs} is subfoliated by the stable foliation \mathcal{W}^s and the center foliation \mathcal{W}^c and that the center-unstable foliation \mathcal{W}^{cu} is subfoliated by the unstable and the center foliation respectively as it is shown in the following proposition by Burns and Wilkinson in [BW08]:

Proposition 1.23. *If there exist foliations \mathcal{W}^{cs} and \mathcal{W}^{cu} as above, then there is a foliation \mathcal{W}^c tangent to E^c . Furthermore, \mathcal{W}^c and \mathcal{W}^u subfoliate \mathcal{W}^{cu} , while \mathcal{W}^c and \mathcal{W}^s subfoliate \mathcal{W}^{cs} .*

This property of dynamical coherence is essential for our investigation of partially hyperbolic systems with a f -invariant compact center foliation with finite holonomy. Due to dynamical coherence any smooth manifold transversal to a center manifold $W^c(x)$ is foliated by stable and unstable leaves induced by the center-stable and center-unstable foliation.

1.2.2 Dynamical coherence for partially hyperbolic systems with a compact center foliation with finite holonomy

We show that under the assumption of an invariant compact center foliation with finite holonomy our system is dynamically coherent. First, we start with the proof of dynamical coherence assuming trivial holonomy.

The idea of the proof is quite intuitive: We consider the stable foliation through a center leaf $W^c(x)$. Any point $y \in \mathcal{W}^s(W^c(x))$ on a stable leaf through $W^c(x)$ approaches $W^c(x)$ by iterations under the diffeomorphism f . Due to the Reeb Stability Theorem 1.6 the Hausdorff distance between $W^c(x)$ and $W^c(y)$ has to shrink, if the distance between two points diminishes. The last step is to show that this implies that the whole center leaf $W^c(y)$ is contained in the stable foliation through $W^c(x)$. As we miss references, we redo the proof by hand.

Compact center foliation with trivial holonomy.

Theorem 1.24. *Let f be a partially hyperbolic C^1 -diffeomorphism. Assume that there exists an invariant compact center foliation \mathcal{W}^c with trivial holonomy. Then f is dynamically coherent.*

Definitions and notations: We call a smooth path $\gamma_s : [0, 1] \rightarrow M$ a *stable path* or just *s-path* if its image $\{\gamma(t)\}_{t \in [0,1]}$ is entirely contained in a single stable leaf $W^s(\gamma(0))$. In an analogous way we introduce the concept of an *unstable path* or *u-path* γ_u . The concatenation $\gamma = \gamma_s \cup \gamma_u$ of a stable path γ_s and a unstable path γ_u such that $\gamma_s(1) = \gamma_u(0)$ is called a *su-path*. We denote with $l(\gamma)$ the length of a smooth path $\gamma : [0, 1] \rightarrow M$. The length $l(\gamma)$ of a *su-path* γ is given by the maximum of the lengths of γ_s and γ_u , i.e.

$$l_{us}(\gamma) := \max \{l(\gamma_s), l(\gamma_u)\}.$$

Proof. We look at the local stable leaves through a center leaf $W_{loc}^s(W^c(x))$ which is - by construction - tangent to the center-stable distribution E^{cs} and we show by contradiction that every center leaf $W^c(y)$ through a point $y \in W_{loc}^s(W^c(x))$ is contained in the local center-stable leaf.

We need the following lemma where $C := \sup_{y \in M} \{\|df(y)\|, \|(df(y))^{-1}\|\}$.

Lemma 1.25. *There exist $\alpha > 0$ and $\eta > 0$ such that if any two points x, y are connected by a *su-path* $\gamma = \gamma_s \cup \gamma_u$ where $\gamma_s \subset W^s(x)$, $\gamma_u \subset W^u(\gamma_u(0))$ are smooth paths and $l_{us}(\gamma) \in [\eta, C\eta]$ then the Hausdorff distance $d_H(W^c(x), W^c(y)) \geq \alpha$.*

Proof. As the Hausdorff metric is continuous it is enough to show that there is $\eta > 0$ such that x and y cannot lie on the same center leaf. By contradiction assume that x, y lie on a common center leaf. Since \mathcal{W}^c is a compact foliation, every leaf is an embedded C^1 -submanifold and its leaf topology coincides with the subspace topology. There exists a C^1 -diffeomorphism $\phi : U \subset M \rightarrow \mathbb{R}^n$ such that $\phi(U \cap W^c(x)) = \phi(U) \cap \mathbb{R}^q$ where $q = \dim W^c(x)$. Since the diffeomorphism is close to isometry, there exists a constant $\beta > 0$ such that if $d_M(x, y) \leq \beta$ then there exists a center path connecting x and y with length less than 2β . Because $\mathcal{W}^u, \mathcal{W}^s, \mathcal{W}^c$ are transversal foliations there cannot exist a triangle formed by a *usc-path* joining x and y such that every segment has length less than 2β . So we only have to choose η such that the path joining x and y with length $\leq 2C\eta$ has length less than β , i.e. $2C\eta < \beta$. Then follows a contradiction to the above and x and y cannot lie on the same leaf. Therefore we can find a positive constant $\alpha > 0$ such that $d_H(W^c(x), W^c(y)) \geq \alpha$. \square

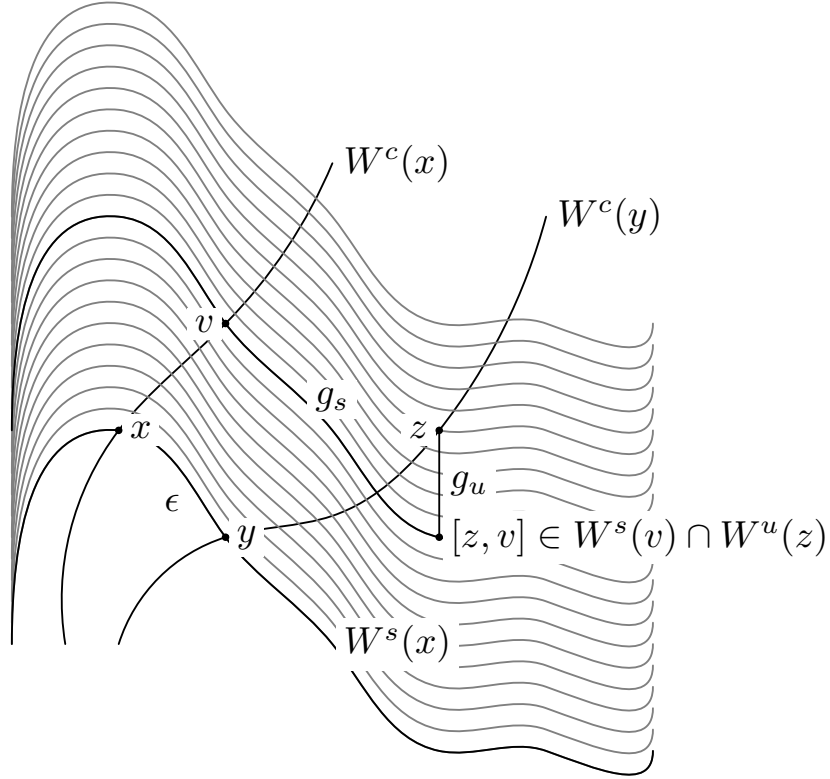

Figure 1.1: Failure of dynamical coherence: Assume that $W^c(y) \not\subset \bigcup_{v \in W^c(x)} W^s(v)$, then there exists a path $\gamma_u \subset W^u(z)$ of positive length between $z \in W^c(y)$ and $W^s(v)$ where $v \in W^c(x)$. Because W^c is assumed to be a compact foliation with finite holonomy, any leaf $W^c(y)$ through a nearby point y , $d(x, y) < \epsilon$, is contained in a small W^c -saturated neighborhood of $W^c(x)$. These two facts yield a contradiction.

We assume that there is a center leaf $W^c(y)$ not contained in $W_{loc}^s(W^c(x))$ where $y \in W_{loc}^s(x)$. We choose $\alpha > 0$ as in Lemma 1.25.

We choose $\alpha > 0$ as in Lemma 1.25. For $\alpha > 0$ there exists $\epsilon > 0$ such that $d(x, y) < \epsilon$ implies that the center leaf $W^c(y)$ is contained in the saturated α -neighbourhood of $W^c(x)$ as shown in Lemma 1.9.

So we choose $n > 0$ such that $d(f^n x, f^n y) < \epsilon$ and denote $x := f^n x$ and $y := f^n y$ again for simplicity. It still holds $W^c(y) \not\subset W_{loc}^s(W^c(x))$. We choose $\eta > 0$ as in Lemma 1.25 and $0 < \eta_0 \leq \eta$ and $z \in W^c(y)$ such that $0 < d_u(z, W_{loc}^s(W^c(x))) \leq \eta_0$ and such that there is a unique intersection point $[z, v] \in W_{loc}^s(W^c(x)) \cap W_{loc}^u(z)$ lying on the local stable leaf $W_{loc}^s(v)$ where $v \in W^c(x)$. So we have a u -path γ_u of minimal length

connecting z and $[z, v]$ and a s -path γ_s of minimal length connecting v and $[z, v]$. Both paths have positive length. There exists a smallest $k \in \mathbb{N}$ such that $\max \{l(f^k \gamma_u), l(f^k \gamma_s)\} \geq \eta_0$. By the choice of C this maximum is bounded from below by η_0 and from above by $C\eta_0$ such that Lemma 1.25 can be applied to the path of maximal length, $f^k \gamma_u$ or $f^k \gamma_s$. This implies that $d_H(W^c(f^k x), W^c(f^k y)) \geq \alpha$ which is a contradiction. \square

Compact center foliation with finite holonomy. Now we can proceed with the proof of dynamical coherence in the case of non-trivial finite center holonomy.

Theorem 1.26. *Let f be a partially hyperbolic C^1 -diffeomorphism. Assume that there exists an invariant compact center foliation \mathcal{W}^c with finite holonomy. Then f is dynamically coherent.*

Before we start with the proof we show the existence of appropriate covers by \mathcal{W}^c -saturated sets such that every neighborhood has a finite holonomy cover where the holonomy of every lifted center leaves vanishes. We denote with

$$B_H(W^c(x), \delta) := \{W^c(y) \subset M \mid d_H(W^c(x), W^c(y)) < \delta\}$$

a \mathcal{W}^c -saturated ball of Hausdorff radius $\delta > 0$.

Lemma 1.27. *Let \mathcal{W}^c be a compact foliation with finite holonomy. Then there exist two covers $\{U_i\}$ and $\{V_i\}$ of open \mathcal{W}^c -saturated sets such that*

1. *there exist covering maps $q_j : \tilde{V}_j \rightarrow V_j$ and $p_i : \tilde{U}_i \rightarrow U_i$ such that the holonomy of every lifted center leaf $\tilde{W}^c(x)$ is trivial and $\tilde{U}_i / \text{Hol} = U_i$, where Hol denotes the holonomy group of maximal order inside U_i , and the analog holds for every V_j ,*
2. *for every U_i there exists V_j such that U_i injects trivially into V_j , the closure \bar{U}_i is relatively compact in V_j and $p_i = q_j|_{\tilde{U}_i}$,*
3. *there exists $\delta_0 > 0$ such that for every $W^c(x) \subset M$ there exists i such that $B_H(W^c(x), \delta_0) \subset U_i$.*

Proof. The statement is a direct consequence of the Reeb Stability Theorem 1.6 and the existence of a Lebesgue number $\delta_0 > 0$ for this cover. \square

We lift the Riemannian metric d canonically to a metric \tilde{d} on every finite cover \tilde{U}_i where we set $\tilde{d}(x, y) = 1$ for points on different connected components. We define with \tilde{d} a Hausdorff metric on \tilde{U}_i and denote both metrics on \tilde{U}_i

1.2. Partially hyperbolic systems

for simplicity with d and d_H again.

As a consequence of the Reeb Stability Theorem 1.6 we have already showed that any two center leaves are close with respect to the Hausdorff metric if two points are sufficiently close. We need the following small Lemma closely related to this fact:

Lemma 1.28. *Given $\{U_i\}, \{V_i\}$ and δ_0 as in Lemma 1.27. For any $x \in M$ and U_i with $B_H(W^c(x), \delta_0) \subset U_i$ and for any $0 < \delta_1 < \frac{1}{2}\delta_0$ there exists $\epsilon > 0$ such that the following holds: It is $\mathcal{W}^c(B_\epsilon(x)) \subset B_H(W^c(x), \delta_1)$ and for $\tilde{x} \in p_i^{-1}x$ it is $\tilde{\mathcal{W}}^c(B_\epsilon(\tilde{x})) \subset B_H(\tilde{W}^c(\tilde{x}), \delta_1)$.*

Proof. The first inclusion is just the statement of Lemma 1.9. Therefore there exists $\epsilon_1 > 0$ such that $\mathcal{W}^c B_{\epsilon_1}(x) \subset B_H(W^c(x), \delta_1)$.

As $\delta_1 > 0$ is sufficiently small such that $B_H(W^c(x), \delta_1)$ is bounded away from the border of U_i and the same holds therefore for the any ball $B_H(\tilde{W}^c(x), \delta_1)$ of a lifted center leaf $\tilde{W}^c(\tilde{x})$ with $\tilde{x} \in p_i^{-1}x$ we can deal with \tilde{W}^c restricted to a ball far away from the border as a compact foliation with trivial holonomy. Hence, we find $\epsilon_2 > 0$ such that $\tilde{\mathcal{W}}^c(B_{\epsilon_2}(\tilde{x})) \subset B_H(\tilde{W}^c(\tilde{x}), \delta_1)$. The statement is implied for $\epsilon := \min\{\epsilon_1, \epsilon_2\}$. \square

Lemma 1.29. *Given $\{U_i\}, \{V_i\}$ and δ_0 as in Lemma 1.27. There exists $\eta > 0$, $C\eta < \delta_0$, and $\alpha > 0$ such that the following hold: For any \tilde{x}, \tilde{y} , for any \tilde{U}_i with $\tilde{W}^c(\tilde{x}), \tilde{W}^c(\tilde{y}) \subset \tilde{U}_i$ at Hausdorff distance b to each other such that $\text{dist}(B_H(\tilde{W}^c(\tilde{x})), 2b, \partial\tilde{U}_i) > \frac{1}{2}\delta_0$, if the connecting su-path γ_{su} from \tilde{x} to \tilde{y} has length $l(\gamma_{su}) \in [\eta, C\eta]$ then the Hausdorff distance $d_H(\tilde{W}^c(x), \tilde{W}^c(y)) \geq \alpha$.*

Proof. The set \tilde{U}_i is relatively compact in some \tilde{V}_j and trivially foliated by the lifted center foliation \tilde{W}^c . Therefore we can treat any \tilde{W}^c -saturated ball inside \tilde{U}_i which is bounded away from the boundary as a compact set trivially foliated by a compact center foliation. Therefore we can apply Lemma 1.25 to \tilde{W}^c inside \tilde{U}_i and find $\alpha_i > 0$ and $\eta_i > 0$. By repeating this for the finitely many \tilde{U}_i we define $\alpha := \min \alpha_i$ and $\eta := \min \eta_i$. \square

Proof. [Theorem 1.26] We fix covers $\{U_i\}$ and $\{V_i\}$ and δ_0 as in Lemma 1.27 and $\delta_1 < \min\{\frac{1}{2}\delta_0, \alpha\}$. Further, we fix $\eta > 0$ and $\alpha > 0$ as in Lemma 1.29. Let $W^c(x) \subset M$. Define the center-stable leaf through x by $W^{cs}(x) := \bigcup_{z \in W^c(x)} W^s(z)$. We assume that there exists $y \in W^s(x)$ such that $W^c(y) \not\subset W^{cs}(x)$.

For $\delta_1 > 0$ there exists according to Lemma 1.28 $\epsilon > 0$ such that $\mathcal{W}^c(B_\epsilon(x)) \subset B_H(W^c(x), \delta_1)$ and $\tilde{\mathcal{W}}^c(B_\epsilon(x)) \subset B_H(\tilde{W}^c(x), \delta_1)$. Hence, we iterate x and y by f^k , $k \geq 0$, such that $d(f^k x, f^k y) < \epsilon$ and $d_s(f^k x, f^k y) < \epsilon$ and consequently, $W^c(f^k y) \subset B_H(W^c(f^k x), \delta_1)$. For simplicity, we denote

$x := f^k x$ and $y := f^k y$.

We consider local center-stable leaf $W_{2\delta_1}^{cs}(x) = \bigcup_{z \in W^c(x)} W_{2\delta_1}^s(x)$ restricted to $B_H(W^c(x), \delta_1)$. It is a compact set in $B_H(W^c(x), \delta_1)$. Then the intersection $W^c(y) \cap W_{2\delta_1}^{cs}(x)$ is compact in $W^c(y)$. We show that the intersection $W^c(y) \cap W_{2\delta_1}^{cs}(x)$ is open inside $W^c(y)$ and hence that $W^c(y) \subset W_{2\delta_1}^{cs}(x)$. With the proof of the following claim we conclude therefore the theorem.

Claim: The intersection $W^c(y) \cap W_{2\delta_1}^{cs}(x)$ is open inside $W^c(y)$.

Proof. First, the intersection is not empty as $y \in W_{2\delta_1}^s(x)$ lies inside. Let $z \in W^c(y) \cap W_{2\delta_1}^{cs}(x)$. Then there exists a stable path γ_s^z with $\gamma_s^z(0) \in W^c(z)$ and $x_z := \gamma_s^z(1) \in W^c(x)$, $\gamma_s^z \subset W_{2\delta_1}^s(x_z)$ and therefore $l(\gamma_s^z) \leq 2\delta_1$. Then there exists a neighborhood $U_z \subset W^c(y)$ such that for all $w \in U_z$ there exists a su-path $\gamma_{su}^w = \gamma_u^w \cup \gamma_s^w$ continuous in w with $l(\gamma_{su}^w) < 4\delta_1$. If $U_z \not\subset W^c(y) \cap W_{2\delta_1}^{cs}(x)$ then there exists $w \in U_z$ such that $l(\gamma_u^w) > 0$. Consequently, we find $k \geq 0$ such that $l(f^k \circ \gamma_u^w) \in [\eta, C\eta]$. Now we consider $f^k(x)$. There exists U_i such that $B_H(W^c(f^k x), \delta_0) \subset U_i$ and $W^c(f^k y) \subset B_H(W^c(f^k x), \delta_1)$ as it is still $d(f^k x, f^k y) < \epsilon$. Hence, we choose $\tilde{x}_z \in p_i^{-1}(f^k(x_z))$ and the corresponding lifted center leaf $\tilde{W}^c(\tilde{x}_z)$. Then there exists a unique lift $\tilde{\gamma}_s^z$ of $f^k \circ \gamma_s^z$ with $\tilde{\gamma}_s^z(0) = \tilde{x}_z$. We find the correct lift of $f^k(z) \in W^c(f^k y)$ by $\tilde{z} := \tilde{\gamma}_s^z(1)$ and consider the lifted center leaf $\tilde{W}^c(\tilde{z})$ through \tilde{z} . By the choice of $\epsilon > 0$ we can conclude that $d_H(\tilde{W}^c(\tilde{x}_z), \tilde{W}^c(\tilde{z})) < \delta_1$. We continue to lift the continuous family of su-paths $f^k \circ \gamma_{su}^w$ for $w \in U_z$ to a continuous family of uniquely lifted su-paths $\tilde{\gamma}_{su}^w$. The constant $\delta_1 > 0$ can be chosen sufficiently small such that p_i are isometries restricted to $B_{2\delta_1}(f^k w)$ and therefore $l(\tilde{\gamma}_u^w) \in [\eta, C\eta]$. We can apply Lemma 1.29 and conclude that $d_H(\tilde{W}^c(x), \tilde{W}^c(y)) \geq \alpha > 0$. At the same time, it is $d_H(\tilde{W}^c(x), \tilde{W}^c(y)) < \delta_1 < \alpha$. \square

With this proof of the claim we finish the proof of Theorem 1.26. \square

Remark 1.30. *We suppose that the center foliation \mathcal{W}^c is invariant so the above implies that the center-stable and center-unstable foliation are f -invariant.*

1.2.3 Further remarks

Central transitivity. We call a partially hyperbolic diffeomorphism $f : M \rightarrow M$ *centrally transitive* if there exists a dense orbit of center leaves, i.e. there exists $x \in M$ such that $\bigcup_{n \in \mathbb{Z}} f^n W^c(x) = M$. Clearly, if a partially hyperbolic diffeomorphism $f : M \rightarrow M$ is transitive, then it is centrally

transitive.

Carrasco states in his thesis [Car10] the following yet not published result:

Theorem 1.31 (Theorem B in [Car10]). *Let $f : M \rightarrow M$ be a partially hyperbolic C^1 -diffeomorphism with an invariant compact center foliation. Assume that f is centrally transitive. Then the center foliation \mathcal{W}^c has only finite holonomy.*

Admitting Carrasco's result to be true we get the following corollary:

Corollary 1.32. *Let $f : M \rightarrow M$ be a partially hyperbolic C^1 -diffeomorphism with an invariant compact center foliation \mathcal{W}^c . Assume that f is centrally transitive. Then f is dynamically coherent.*

Proof. It is shown in Theorem 1.31 by Carrasco in [Car10] under the assumptions above that the center foliation has finite holonomy. By Theorem 1.24 we can conclude that f is dynamically coherent. \square

Non-compactness of center-unstable and center-stable leaves. At this moment we can prove a further result in any dimension about the center-unstable and center-stable foliation \mathcal{W}^{cu} and \mathcal{W}^{cs} of a partially hyperbolic diffeomorphism.

Theorem 1.33. *Let $f : M \rightarrow M$ be a partially hyperbolic C^1 -diffeomorphism. Assume that there is a f -invariant center foliation with finite holonomy. Then every leaf of the center-unstable foliation \mathcal{W}^{cu} is non-compact. The same holds for every leaf of the center-stable foliation \mathcal{W}^{cs} .*

Proof. We assume that there exists a compact center-stable leaf $W^{cs}(x) = \mathcal{W}^s(W^c(x))$. We prove the following two lemmata under this assumption which yield a contradiction and therefore the proof of Theorem 1.33.

Lemma 1.34. *Under the assumptions of Theorem 1.33 and that one center leaf $W^{cs}(x)$ is compact it is implied that for all $n \in \mathbb{N}, r > 0$ there exist $y, z \in M$ such that $\sharp \{W_r^s(y) \cap W^c(z)\} > n$ with $W_r^s(y) = W^s(y) \cap B_r(y)$.*

Proof. The center-stable leaf $W^{cs}(x)$ is - due to dynamical coherence - sub-foliated by the two transversal foliations \mathcal{W}^c and \mathcal{W}^s . Every stable leaf $W^s(y_0)$ with $y_0 \in W^{cs}(x)$ is non-compact. Therefore we can find for any $n \in \mathbb{N}$ a center leaf $W^c(z_0) \subset W^{cs}(x)$ such that $\sharp \{W^c(z_0) \cap W^s(y_0)\} > n$. We denote the intersection points with $\{w_1, \dots, w_m\}$ where $m > n$. They all lie on the stable leaf $W^s(y_0)$ and consequently, the distance along the stable leaf $d_s(f^n w_i, f^n w_j) \rightarrow 0$ converges to zero for $n \rightarrow \infty$ and any

$1 \leq i, j \leq m$. Hence, for any $r > 0$ we can find a $N \in \mathbb{N}$ such that the points $\{f^N w_1, \dots, f^N w_m\}$ are contained inside a ball $B_r(f^N w_1)$ of radius $r > 0$. Because of the invariance of the foliations we obtain that $f^N W^s(y_0) \cap f^N W^c(z_0)$ all lie inside $W_r^s(f^N w_1)$. The points $z := f^N z_0$ and $y := f^N w_1$ fulfill the statement above. \square

Lemma 1.35. *Under the assumptions of Theorem 1.33 there exists $r > 0$, $n \in \mathbb{N}$ such that for all $y, z \in M$ it holds $\sharp \{W_r^s(y) \cap W^c(z)\} < n$.*

Proof. Since \mathcal{W}^c is a compact foliation with finite holonomy any two leaves can be separated by arbitrarily small \mathcal{W}^c -saturated neighborhoods. So first of all, consider an arbitrary leaf $W^c(z)$ and an embedded transverse disk $\phi : D^q \rightarrow M$ with $\phi(0) = z$. There exists a neighborhood U in $\phi(D^q)$ such that U is invariant under the holonomy group of $W^c(z)$ and there always exists a saturated neighborhood V of $W^c(z)$ whose intersection with $\phi(D^q)$ is contained in U . We consider the connected component N of V which contains $W^c(z)$ and $N_0 := N \cap \phi(D^q)$. Suppose that N_0 is not closed in $\phi(D^q)$ then there exists an accumulation point $\bar{z} \in \phi(D^q)$ but not in N_0 . But then there is a leaf $W^c(\bar{z})$ distinct from $W^c(z)$ contained in the Hausdorff neighborhood of $W^c(z)$ which can't be separated from $W^c(z)$ by a saturated neighborhood as it is an accumulation point of N_0 . This contradicts the finite holonomy of $W^c(z)$ and therefore $N_0 \cap \phi(D^q)$ is compact in $\phi(D^q)$ and finite. Suppose $N_0 \cap \phi(D^q)$ contain a infinite number of points, then there is an accumulation point $\bar{z} \in N_0 \cap \phi(D^q)$. Then $\bar{z} \in W^c(z)$ is implied but then there would be a non-periodic holonomy homeomorphism contradicting the finite holonomy. Hence, we find $n \in \mathbb{N}$ such that the number of intersections $N \cap \phi(D^q)$ is bounded by n .

We can restrict ourselves to $y \in M$ such that $W^s(y)$ intersects $W^c(z)$ and accordingly, it is contained in the center-stable leaf $W^{cs}(z)$. Otherwise the statement is trivially fulfilled. Then we can find $r > 0$ sufficiently small such that $W_r^s(y)$ lies inside a plaque and is therefore homeomorphic to an embedded disk, transverse to the center foliation inside the center-stable leaf $W^{cs}(z)$, and we can apply the above. \square

Combining both lemmata we get a contradiction and prove the theorem. \square

1.3 Dynamics on the leaf space

During the proofs of our main theorems we work in the leaf space M/\mathcal{W}^c of the center foliation \mathcal{W}^c which is constructed by identifying all points in the same center leaf. In this part we summarize the relevant properties of the

1.3. Dynamics on the leaf space

leaf space and of the induced homeomorphism F by f on the leaf space. As we will see in the following the induced homeomorphism F is hyperbolic in a topological sense on the leaf space.

In general, the leaf space of a foliation is not even Hausdorff. But the equivalent conditions in Theorem 1.8 by Epstein guarantee that the leaf space is Hausdorff if and only if the foliation is compact with finite holonomy. The canonical quotient map $\pi : M \rightarrow M/\mathcal{W}^c$ is continuous with respect to the quotient topology and always open, because the set of leaves meeting an open set is open for every foliation. We show in the following theorem that the quotient topology is generated by the Hausdorff metric d_H for $\bar{x} = \pi W^c(x), \bar{y} = \pi W^c(y) \in M/\mathcal{W}^c$ defined by

$$d_H(W^c(x), W^c(y)) = \max \left\{ \max_{\tilde{x} \in W^c(x)} d(\tilde{x}, W^c(y)); \max_{\tilde{y} \in W^c(y)} d(\tilde{y}, W^c(x)) \right\}$$

between center leaves in M and hence, M/\mathcal{W}^c is a compact metric space.

Theorem 1.36. *Let $f : M \rightarrow M$ be a partially hyperbolic C^1 -diffeomorphism on a compact manifold M with a compact center foliation \mathcal{W}^c with finite holonomy. Then the leaf space M/\mathcal{W}^c is a compact metric space with the Hausdorff metric d_H and the topology induced by the Hausdorff metric coincides with the quotient topology.*

Proof. We know by Theorem 1.8 that the leaf space M/\mathcal{W}^c is a compact Hausdorff space: Any two center leaves can be separated by \mathcal{W}^c -saturated open sets. The Hausdorff metric is a metric on non-empty compact sets and induces therefore a metric on the leaf space so it is a compact metric space. For the second statement we start with showing the easier direction:

$$\pi^{-1}U \text{ is open in } M \Rightarrow U \text{ is open w.r.t. the Hausdorff metric in } M/\mathcal{W}^c.$$

Let $x \in U$ be an arbitrary point. Since $\pi^{-1}U$ is open, we find to every point $\tilde{x} \in \pi^{-1}x$ an $\epsilon(\tilde{x})$ -ball $B(\tilde{x}, \epsilon(\tilde{x}))$ which lies entirely in $\pi^{-1}U$. Since $\pi^{-1}x$ is compact, we find a finite subcover of ϵ -balls and we can choose a minimal ϵ such that the subcover $\bigcup_{i=1}^n \{B(\tilde{x}_i, \epsilon) \mid \tilde{x}_i \in \pi^{-1}x\}$ by this ϵ -balls lies in $\pi^{-1}U$. Suppose U is not open in M/\mathcal{W}^c . Then there exists a sequence $\epsilon_n \rightarrow 0$ with $\epsilon_n > 0$ and there exist $y_n \in M/\mathcal{W}^c$ such that $d_H(\pi^{-1}x, \pi^{-1}y_n) < \epsilon_n$ but $\pi^{-1}y_n \not\subset \pi^{-1}U$. Hence, we can find to $\tilde{x} \in \pi^{-1}(x)$ a point $\tilde{y}_n \in \pi^{-1}y_n$ such that $\tilde{y}_n \in B(\tilde{x}, \epsilon_n)$. For n sufficiently big, it holds $B(\tilde{x}, \epsilon_n) \subset \pi^{-1}U$ and, since $\pi^{-1}U$ is a \mathcal{W}^c -saturated set, it follows that $\pi^{-1}y_n \subset \pi^{-1}U$ for n sufficiently big contradicting the assumption. Secondly, it is to show:

$$U \text{ open w.r.t. the Hausdorff metric in } M/\mathcal{W}^c \Rightarrow \pi^{-1}U \text{ is open in } M.$$

Let $\tilde{x} \in M$ be an arbitrary point in M . Since U is open with respect to the Hausdorff metric there exists a δ -Hausdorff neighbourhood $B_H(W^c(\tilde{x}), \delta)$ such that for any $\tilde{y} \in B_H(W^c(\tilde{x}), \delta)$ it holds $W^c(\tilde{y}) \subset \pi^{-1}U$. Applying Lemma 1.9 we can find to $\tilde{x} \in \pi^{-1}U \subset M$ an $\epsilon > 0$ such that $W^c(B(\tilde{x}, \epsilon)) \subset B_H(W^c(\tilde{x}), \delta)$, and therefore the neighbourhood $B(\tilde{x}, \epsilon)$ lies in $\pi^{-1}U$ and $\pi^{-1}U$ is open in M . \square

1.3.1 Compact center leaves with trivial holonomy

If the holonomy of a compact foliation is trivial for every leaf, then the leaf space is a topological manifold and the quotient map $\pi : M \rightarrow M/\mathcal{W}^c$ defines a (topological) fiber bundle. For the moment we consider this special case and generalize then the obtained properties, if possible, to the case of a compact center foliation with finite, non-trivial holonomy.

Expansivity of F . The projected map $\pi \circ f \circ \pi^{-1} =: F : M/\mathcal{W}^c \rightarrow M/\mathcal{W}^c$ is well-defined because of the f -invariance of the center foliation. It is a homeomorphism because f is a homeomorphism and π is continuous and open. A homeomorphism $f : X \rightarrow X$ on a compact metric space (X, d) is called *expansive* if there exists $\alpha > 0$ such that for any $x, y \in X$ with $x \neq y$ there exists $n \in \mathbb{Z}$ such that $d(f^n x, f^n y) \geq \alpha$. We adopt a proof by Bonatti and Wilkinson in [BW05a], based on a proof by Hirsch, Pugh and Shub [HPS70], to show the expansiveness of F :

Theorem 1.37. *Let $f : M \rightarrow M$ be a partially hyperbolic C^1 -diffeomorphism with a compact f -invariant center foliation with trivial holonomy. Then $F : M/\mathcal{W}^c \rightarrow M/\mathcal{W}^c$ is expansive.*

Proof. We need the following lemma.

Lemma 1.38. *For any $\eta > 0$ exists $\delta > 0$ such that for any $x, y \in M$ with $d_H(W^c(x), W^c(y)) < \delta$ there exists a su-path $\gamma = \gamma_s \cup \gamma_u$ with γ_u, γ_s smooth subsegments, $\gamma_u \subset W^u(\gamma_u(0))$, $\gamma_s \subset W^s(\gamma_s(0))$, such that $l_{su}(\gamma) \leq \eta$ and $\gamma(0) \in W^c(x), \gamma(1) \in W^c(y)$.*

Proof. The center stable foliation \mathcal{W}^{cs} is transversal to the unstable foliation \mathcal{W}^u and - as f is dynamically coherent by Theorem 1.24 - \mathcal{W}^{cs} is subfoliated by the transverse foliations \mathcal{W}^c and \mathcal{W}^s . Therefore, for some $p \in W^c(x)$ the stable leaf $W^s(p)$ intersects $W^u(q)$ for some $q \in W^c(y)$, if the center leaves $W^c(x)$ and $W^c(y)$ lie sufficiently close to each other. Since the intersection of \mathcal{W}^{cs} and \mathcal{W}^u is transversal, the length $l_{us}(\gamma)$ is bounded. \square

1.3. Dynamics on the leaf space

Choose α, η as in Lemma 1.25 and choose $\delta = \delta(\eta)$ as in Lemma 1.38. Define $\alpha_0 := \min\{\delta, \alpha\}$. Let $\bar{x} = \pi W^c(x) \neq \bar{y} = \pi W^c(y)$ be two points in M/\mathcal{W}^c such that $d_H(W^c(x), W^c(y)) \leq \alpha_0$. Because of Lemma 1.38 there exists a smooth path $\gamma : [0, 1] \rightarrow M$ with $\gamma(0) \in W^c(x), \gamma(1) \in W^c(y)$ and $l_{su}(\gamma) \leq \eta$. At least one piece γ_s or γ_u will have positive length, therefore we find k as smallest number such that the inequality $\max\{l_{us}(f^{-k} \circ \gamma), l_{us}(f^k \circ \gamma)\} \geq \eta$ holds. Because of the choice of C in Theorem 1.24 it must hold either $l_{us}(f^k \circ \gamma) \in [\eta, C\eta]$ or $l_{us}(f^{-k} \circ \gamma) \in [\eta, C\eta]$. Therefore either $f^k \circ \gamma$ or $f^{-k} \circ \gamma$ fulfills the conditions of Lemma 1.25 and this implies $d_H(W^c(f^k(x)), W^c(f^k(y))) \geq \alpha \geq \alpha_0$. Therefore F is expansive with expansivity constant α_0 . \square

Remark 1.39. *If the holonomy of the center leaves is non-trivial, the induced map F on the quotient might not be expansive as it is the case in the following example by Bonatti and Wilkinson in [BW05a]. For a better understanding recall the construction of a foliation in Example 1.12:*

Let $f : \mathbb{T}^2 \rightarrow \mathbb{T}^2$ be a hyperbolic linear map on the torus induced by $A \in \text{SL}(2, \mathbb{Z})$. Let $\phi : \mathbb{T}^2 \rightarrow \mathbb{S}^1$ be a smooth map such that $\phi(-x) = \phi(x)$ for every $x \in \mathbb{T}^2$. Then there is an induced skew product on the 3-Torus $\mathbb{T}^2 \times \mathbb{S}^1$ defined by $f_\phi(x, \theta) = (f(x), \phi(x) + \frac{1}{2})$. Then f_ϕ commutes with the reflection $S(x, \theta) = (-x, \theta + \frac{1}{2})$ on the 2-torus. It is a fix-point free action of a finite group, hence, $M := \mathbb{T}^2 \times \mathbb{S}^1 / S$ is a compact manifold with an induced partially hyperbolic system f_ϕ . The leaf space of the center foliation is not a manifold, but an orbifold with underlying manifold a 2-sphere and four singular points corresponding to the fix points of S on \mathbb{T}^2 . The induced map F_ϕ on the quotient is not expansive because in a neighborhood of a singular leaf there exist heteroclinic orbits of points $x, y \in M, x \neq y$ such that $W^s(x) \cap W^u(y) = \{z_1, z_2\}$ and hence, the orbit will not leave a small neighborhood. Consequently, for every $\alpha > 0$ there are points x, y on a heteroclinic orbit in a neighborhood of a singular leaf such that $d(f^n x, f^n y) < \alpha$ for all $n \in \mathbb{Z}$.

Local product structure on V . If a compact center foliation has only trivial holonomy, the leaf space $V := M/\mathcal{W}^c$ is a compact topological manifold. The center-stable and center-unstable foliation \mathcal{W}^{cs} and \mathcal{W}^{cu} induce two transverse C^0 -foliations \mathcal{W}^s and \mathcal{W}^u on V . We can show that they coincide with the stable and unstable equivalence classes defined by

$$\begin{aligned} x \sim_s y & :\Leftrightarrow \lim_{n \rightarrow \infty} d_H(f^n(\pi^{-1}x), f^n(\pi^{-1}y)) = 0, \\ x \sim_u y & :\Leftrightarrow \lim_{n \rightarrow \infty} d_H(f^{-n}(\pi^{-1}x), f^{-n}(\pi^{-1}y)) = 0. \end{aligned}$$

We denote the stable and unstable equivalence class of x with $[x]_s$ and $[x]_u$ respectively.

Theorem 1.40. *Let $f : M \rightarrow M$ be a partially hyperbolic C^1 -diffeomorphism with a compact f -invariant center foliation \mathcal{W}^c with trivial holonomy. Let $\pi : M \rightarrow M/\mathcal{W}^c$ be the canonical quotient map. Then for every $x \in M$ it is $\pi W^{cs}(x) = [\pi x]_s$ and $\pi W^{cu}(x) = [\pi x]_u$.*

Proof. Due to dynamical coherence it is obvious that center leaves in the same center-stable leaf lie in the same stable equivalence class, and the analogous statement holds for center leaves in the same center-unstable leaf. So it remains to prove $[\pi x]_s \subset \pi W^{cs}(x)$ and $[\pi x]_u \subset \pi W^{cu}(x)$. For this we need the following lemma:

Lemma 1.41. *Let $x, y \in M/\mathcal{W}^c$ with $x \sim_s y$ with respect to the Hausdorff metric d_H . Then there exist $\tilde{x} \in \pi^{-1}(x), \tilde{y} \in \pi^{-1}(y)$ such that $\tilde{x} \in W^s(\tilde{y})$.*

Proof. Let $x \sim_s y$ in M/\mathcal{W}^c . We choose $\alpha > 0$ and $\eta > 0$ as in Lemma 1.25 and $\delta(\eta)$ as in Lemma 1.38. We denote $\alpha_0 := \min\{\alpha, \delta\}$. Then we choose a fixed $n > N(\alpha_0)$ such that

$$d_H(W^c(f^n(\tilde{x})), W^c(f^n(\tilde{y}))) < \alpha_0, \quad \pi\tilde{x} = x, \quad \pi\tilde{y} = y.$$

We apply Lemma 1.38. Then there exists a su -path $\gamma := \gamma_s \cup \gamma_u$ with length $l_{us}(\gamma) \leq \eta$ and there are points $\tilde{x} \in f^n(\pi^{-1}x)$ and $\tilde{y} \in f^n(\pi^{-1}y)$ such that $\gamma(0) = \tilde{x}$ and $\gamma(1) = \tilde{y}$. We assume $l(\gamma_u) > 0$. Then there exists $k \geq 1$ such that $l(f^k \circ \gamma_u) \in [\eta, C\eta]$ with C defined in Theorem 1.24. Applying Lemma 1.25 we get a contradiction. Hence, $l(\gamma_u) = 0$ is implied and $\gamma = \gamma_s$ with $\gamma_s(1) \in W^s(\gamma_s(0))$. □

So it is proved that the induced foliations coincide with the stable and unstable equivalence classes. □

Assume again that the center foliation has only trivial holonomy, then we have two transverse foliations on M/\mathcal{W}^c , i.e. we say that there is a *local product structure* in $x \in M/\mathcal{W}^c$ if there is a neighborhood U of x and a homeomorphism $h : U \rightarrow B^n \subset \mathbb{R}^n$ such that $U \cap W^s(x)$ is a union of plaques $h^{-1}(\{y\} \times B^{n-q})$ and $U \cap W^u(x)$ is a union of plaques $h^{-1}(B^q \times \{y\})$ where $q = \text{codim } \mathcal{W}^s = \text{dim } \mathcal{W}^u$. The local product structure is called *uniform* if there exists $r > 0$ such that for every $x \in V$ the open ball $B(x, r)$ admits a local product structure. As both foliations on M/\mathcal{W}^c are transverse and intersect in exactly one point we have a local product structure on the leaf space because we can construct h in the following way: Let (U, ϕ)

1.3. Dynamics on the leaf space

be a foliated chart of \mathcal{W}^s where $\phi : U \rightarrow B^q \times B^{n-q} \subset \mathbb{R}^n$ is a homeomorphism with $q = \text{codim } \mathcal{W}^s$. Let (V, ψ) be a foliated chart of \mathcal{W}^u with $n - q = \text{codim } \mathcal{W}^u$ and $V \subset U$. Then we can define $h = (\text{pr}_1 \circ \psi, \text{pr}_2 \circ \phi)$ on V and $h^{-1}(\{y\} \times B^{n-q}) = \phi^{-1}(\{y\} \times B^{n-q})$ define the plaques of the stable foliation. In the same way $h^{-1}(B^q \times \{y\})$ define the plaques of the unstable foliation. So h is a foliated chart for both foliations. The local product structure is clearly uniform as V is compact.

With the following theorem by Ombach in [Omb86] we can show that the homeomorphism F on the leaf space has the pseudo-orbit tracing property if the center foliation has only trivial holonomy.

Theorem 1.42 (Ombach). *Let $f : X \rightarrow X$ be an expansive homeomorphism on a compact metric space X with a uniform local product structure. Then f has the pseudo-orbit tracing property, i.e. if for all $\epsilon > 0$ there exists $\delta > 0$ such that if $\{x_n\}_{n \in \mathbb{Z}}$ verifies $d(x_n, f(x_{n-1})) < \epsilon$ for all $n \in \mathbb{Z}$ then there exists $x \in X$ such that $d(f^n x, x_n) < \delta$ for all $n \in \mathbb{Z}$.*

Using the pseudo-orbit tracing property and expansivity of F we can prove further properties where M denotes a topological manifold and $\mathcal{W}^s, \mathcal{W}^u$ topological foliations in the following (for the respective proofs in the case of an Anosov diffeomorphism see for example [Gun05]):

Lemma 1.43. *If a homeomorphism $f : M \rightarrow M$ has the pseudo-orbit tracing property and is expansive then the set of periodic points lies densely in the set $\Omega(f)$ of non-wandering points.*

Proof. Let $x \in \Omega(f)$ be an arbitrarily chosen point. Then there exists to any $\epsilon > 0$ an integer $N \in \mathbb{Z}$ such that $f^N B_\epsilon(x) \cap B_\epsilon(x) \neq \emptyset$. Therefore we have $y \in f^N B_\epsilon(x) \cap B_\epsilon(x)$ such that $d(y, x) < \epsilon$ and $d(f^N y, x) < \epsilon$. The set $\{y_n\}_{n=0}^N := \{y, f y, f^2 y, \dots, f^N y\}$ is a closed 2ϵ -pseudo-orbit. Therefore we can find $\delta(\epsilon) > 0$ and a closed orbit of z such that $d(f^n z, y_n) < \delta$ for $n = 0, \dots, N$ and $f^N z = z$. This shadowing orbit of z is unique because of the expansivity of f . As $\epsilon > 0$ can be chosen arbitrarily small, we can conclude that the periodic points lie densely in $\Omega(f)$. \square

Lemma 1.44. *If $\Omega(f) = M$, then every stable leaf $W^s(x)$ and every unstable leaf $W^u(x)$ are dense in M .*

Proof. As periodic points are dense in $\Omega(f)$ we can find a finite $\frac{\epsilon}{4}$ -dense set $\{x_1, \dots, x_k\}$ of periodic points. Denote by N the minimal number such that $f^N x_i = x_i$ for $i = 1, \dots, k$ and define $g := f^N$. Then we can show the following:

Lemma 1.45. *There exists $q \in \mathbb{N}$ with the following property: If $d(x_i, x_j) < \frac{\epsilon}{2}$ and $y \in M$ such that $d(x_i, W^u(y)) < \frac{\epsilon}{2}$, then it is $d(x_j, g^{nq}(W^u(y))) < \frac{\epsilon}{2}$ for all $n \in \mathbb{N}$.*

Proof. We can find $z \in W^u(y) \cap W_\epsilon^s(x_i)$. Therefore there exists $N_1 \in \mathbb{N}$ such that for all $n \geq N_1$ it holds $d(g^n z, x_i) < \frac{\epsilon}{2}$ and therefore $d(g^n z, x_j) < \epsilon$ is implied. Again we can find $w \in W^u(g^n z) \cap W_\epsilon^s(x_j)$ and $N_2 \in \mathbb{N}$ such that for all $n \geq N_2$ it holds $d(g^n w, x_j) < \frac{\epsilon}{2}$. If we choose $q = N_1 + N_2$ the statement is implied. \square

As the set of periodic points $\{x_1, \dots, x_k\}$ is finite we can reach every point x_i from every point x_j in a finite number of ϵ -steps. Denote with K the maximal number of necessary steps. Then applying the lemma above iteratively implies that $g^{Kq}W^u(y)$ is ϵ -dense in M . The same argument for f^{-1} shows the density of every stable leaf. \square

Transitivity of F. We recall that a partially hyperbolic diffeomorphism $f : M \rightarrow M$ is said to be *centrally transitive* if there exists a dense orbit of center leaves, i.e. there exists $x \in M$ such that $\overline{\bigcup_{n \in \mathbb{Z}} f^n W^c(x)} = M$. Equivalently, the map F on the leaf space is transitive. With Lemma 1.44 we can conclude - assuming trivial center holonomy - that every topological stable and unstable leaf $W^s(x)$ and $W^u(x)$ for $x \in V$ are dense in the leaf space V , if F is transitive.

Foliations by \mathbb{R}^n . Assuming trivial center holonomy every stable leaf in the leaf space V is homeomorphic to \mathbb{R}^n if $\dim W^s(x) = n$. This is a classical result proved by Hirsch, Pugh and Shub. We prove it here for topological stable and unstable foliations.

Lemma 1.46. *Every stable leaf $W^s(x)$ is homeomorphic to \mathbb{R}^n where $n = \dim W^s(x)$.*

Proof. It is known that any contractible n -manifold which is also simply connected at infinity is homeomorphic to \mathbb{R}^n . So we have to show that $W^s(x)$ is contractible and simply connected at infinity. We start with showing contractibility: We assume that the fundamental group $\pi_1(\tilde{W}^s(x))$ of an arbitrary leaf $\tilde{W}^s(x)$ of the stable foliation \tilde{W}^s on V is non-trivial. Then there exists a path $\gamma \in \pi_1(\tilde{W}^s(x))$ that is not null-homotopic. Then every n th-iterate $f^n \gamma$ is not null-homotopic, but the length of this path $l(f^n \gamma)$ tends to zero for $n \rightarrow \infty$. Fix $n \geq 0$ such that $f^n(\gamma)$ lies inside one plaque of the stable foliation. Every plaque is simply connected, therefore it is

implied that $f^n\gamma$ is null-homotopic contradicting the assumption. Therefore we have $\pi_1(W^s(x)) = 0$ for any stable leaf. As $W^s(x) = \bigcup_{n \geq 0} f^{-n}W_\epsilon^s(f^n x)$ is constructed by gluing together disks along the orbit of x we can find a subsequence $n_j \rightarrow \infty$ such that $f^{-n_j}W_\epsilon^s(f^{n_j}x) \subset f^{-n_{j+1}}W_\epsilon^s(f^{n_{j+1}}(x))$ is an increasing union of n -dimensional disks. Hence, it is clear that the stable manifold is contractible because any ball inside $W^s(x)$ can be contracted by f^n to a point.

Secondly, we show that $W^s(x)$ is simply connected at infinity, i.e. for every compact subset $C \subset W^s(x)$ there exists a compact subset $D \supset C$ such that the induced map $\pi_1(W^s(x) \setminus D) \rightarrow \pi_1(W^s(x) \setminus C)$ is trivial. We construct $D := \bigcup_{n=0}^m f^{-n}C$ where $m > 0$ is chosen sufficiently big such that the length of any path γ is shrunk by f^m to a length smaller than the diameter of a chart neighborhood of $W^s(x)$. Clearly, $D \supset C$ and D is compact. Then we consider any non-trivial closed path γ inside $W^s(x) \setminus D$. Then exists $0 < n < m$ such that $f^n\gamma$ lies inside $W^s(x) \setminus C$ and entirely inside one local chart neighborhood of $W^s(x)$, therefore $f^n\gamma$ is null-homotopic because locally $W^s(x)$ is homeomorphic to a n -dimensional disk. \square

Codimension-3 center foliation. In the special case of a compact center foliation of codimension 3 with trivial holonomy we can apply the following theorem by Vieitez which shows that a uniform local product structure and the existence of an expansive transitive homeomorphism on a topological compact 3-manifold implies that the manifold is the 3-torus.

Theorem 1.47 (Vieitez, [Vie99]). *Let V be a compact connected oriented 3-dimensional boundaryless manifold and $F : V \rightarrow V$ an expansive homeomorphism. Assume that the stable sets of F form a C^0 -foliation of V of codimension 1 and the unstable sets a transverse C^0 -foliation of dimension 1, and $\Omega(F) = V$. Then V is homeomorphic to \mathbb{T}^3 .*

Then we can apply the following theorem by Hiraide to conclude that F is always conjugate to a hyperbolic toral automorphism:

Theorem 1.48 (Hiraide, [Hir89]). *Let $F : \mathbb{T}^n \rightarrow \mathbb{T}^n$ be a homeomorphism of the n -torus. If F is expansive and has the pseudo-orbit tracing property, then F is topologically conjugate to a hyperbolic toral automorphism.*

1.3.2 Compact center leaves with finite holonomy

We recall that the induced map F on the leaf space might not be expansive in the case of a center leaf with non-trivial holonomy. For this reason it is not possible to use the known results about expansive homeomorphisms on

compact metric space immediately. But still, we do have stable and unstable equivalence classes which form almost transverse topological foliations except in some singular points, hence, we can still exploit hyperbolic features in the case of non-trivial holonomy.

Conley-Theory in the leaf space. If the holonomy is finite, but non-trivial, we can nevertheless say something about the dynamics of F on the quotient because we still have a homeomorphism F on a compact metric space X endowed with stable and unstable equivalence classes. We are quite close to a topological hyperbolic map, hence, we show - with the help of the decomposition of the chain-recurrent set - that we can recover in the proof of Theorem 2.7 a spectral decomposition of the chain-recurrent set F . Hence, first we define the relevant objects in this context following [Con78]. A set $Y \subset X$ is called a *chain-recurrent set* if for every point $x \in Y$ there exists a finite chain of points $x = x_0, x_1, \dots, x_k = x$ such that $d(F(x_i), x_{i+1}) < \epsilon$ for every $\epsilon > 0$. A set Y is called *chain-transitive* if any two points $x, y \in Y$ for every $\epsilon > 0$ can be joined by a finite ϵ -chain $x = x_0, x_1, \dots, x_k = y$ such that $d(f(x_i), x_{i+1}) < \epsilon$ for $i = 0, \dots, n - 1$. We denote with $\text{CR}(F)$ the chain-recurrent set which is the union of the equivalence classes which are called chain-recurrent classes and coincide with the chain-transitive sets. More precisely, we can characterize the chain-recurrent class with the help of Ω -sets of $x \in X$ define by

$$\begin{aligned} \Omega(x, F) &:= \{y \in X \mid \forall \epsilon > 0 : \exists \epsilon\text{-chain from } y \text{ to } x\}, \\ \Omega^*(x, F) &:= \{y \in X \mid \forall \epsilon > 0 : \exists \epsilon\text{-chain from } x \text{ to } y\}. \end{aligned}$$

Then every chain-recurrent class coincides with the intersection $\Omega(x, F) \cap \Omega^*(x, F)$, and it is a closed and F -invariant set. We call $A \subset X$ a *Conley attractor* if there exists a neighborhood U of A such that $F(\bar{U}) \subset \text{int}(U)$ and $\bigcap_{n \geq 0} F^n U = A$. We call a set $R \subset X$ a *Conley repeller* if there exists a neighborhood U of R such that $F^{-1}(\bar{U}) \subset \text{int}(U)$ and $\bigcap_{n \geq 0} F^{-n} U = R$.

Orbifold structure on V . A leaf space M/\mathcal{F} is said to have an *orbifold structure* if there is a countable cover (V_i) of M by \mathcal{F} -saturated open sets $V_i \subset M$ such that any V_i is diffeomorphic to the flat bundle $\tilde{L}_i \times_{H_i} T_i$ where H_i is a finite holonomy group of L_i acting linearly on the smooth transversal T_i and \tilde{L}_i the holonomy cover of L_i such that $\tilde{L}_i/H_i = L_i$. Then there is an open embedding $\phi_i : T_i/H_i \rightarrow M/\mathcal{F}$ and $\phi_i(T_i/H_i) \cong T_i/H_i$ form an open cover of the leaf space M/\mathcal{F} . If the compact foliation with finite holonomy is smooth, then we can conclude from the Reeb Stability Theorem that the leaf space V has an orbifold structure. Every sufficiently small neighborhood

in V/\mathcal{W}^c of a leaf $W^c(x)$ is then homeomorphic to \mathbb{R}^q/Γ_x where $\Gamma_x \subset O(q)$ and $q = \text{codim } \mathcal{W}^c$. But the assumption of a smooth foliation is essential such that we obtain holonomy groups as subgroups of the diffeomorphism group of a ball rather than a homeomorphism group. In that case Bochner proved in [Boc45] that any compact group of smooth transformations on a smooth manifold acts in a neighborhood of a fixed point linearly (in appropriate coordinates). In the case of a codimension-2 foliation it is known due to Theorem 1.14 by Kerékjártó that any finite group action is conjugate to a linear orthogonal action, and we use this result in our proofs below. The leaf space is locally a 2-dimensional orbifold and they are all classified by its singular points, in our case by the leaves with non-trivial holonomy group. But in codimension-3 there exists a counterexample by Bing in [Bin52] of a 2-periodic transformation of S^3 into itself that is not conjugate to a product of rotations, reflections and translations. So in higher codimensions, we cannot make use of the orbifold structure of M/\mathcal{W}^c and apply theorems e.g. about the structure of fixed point sets of the holonomy groups. So we remark that in general in codimension ≥ 3 the leaf space M/\mathcal{W}^c cannot be known to be an orbifold a priori. Nevertheless it remains an interesting question if the dynamical restrictions of the partially hyperbolic systems on the foliations and holonomy groups allow the existence of such a non-differentiable action of a finite holonomy group.

1.3.3 Shadowing Lemma for compact center foliations with finite holonomy

In this section we prove the Shadowing Lemma on the leaf space M/\mathcal{W}^c for the homeomorphism F induced by a partially hyperbolic C^1 -diffeomorphism $f : M \rightarrow M$ with an invariant compact center foliation \mathcal{W}^c with finite holonomy.

First, we reconstruct the classical proof of the Shadowing Lemma by Bowen in [Bow75] in the setting of a hyperbolic C^1 -diffeomorphism F on a smooth compact manifold M . It is quite helpful to consider this proof in all its details in order to extract the essentially required properties of F and M for accomplishing the proof.

The second part of this section we start with a list of five properties which are necessary in order to prove the Shadowing Lemma in the setting of a partially hyperbolic diffeomorphism with a compact center foliation with trivial holonomy, and in the following, we recover these enumerated properties, and therefore the proof of the Shadowing Lemma. We finish this section with conferring this construction on the case of a compact center foliation with

non-trivial finite holonomy.

We remark that this section does not impose any restrictions on the dimension or codimension of the center foliation.

Classical proof of the Shadowing Lemma

Theorem 1.49 (Classical Shadowing Lemma). *Let $F : M \rightarrow M$ be a hyperbolic C^1 -diffeomorphism on a smooth compact manifold M . Then F has the pseudo-orbit tracing property.*

We call a sequence $\{x_j\}_{j \in \mathbb{Z}}$ of points $x_j \in M$ a δ -pseudo orbit of F if $d(x_j, F(x_{j-1})) < \delta$ for all $j \in \mathbb{Z}$. We show that for every $\epsilon > 0$ there exists $\delta > 0$ such that every δ -pseudo orbit $\{x_j\}_{j \in \mathbb{Z}}$ of F is ϵ -shadowed by an orbit of F , i.e. there exists $z \in M$ such that $d(F^j(z), x_j) < \epsilon$ for all $j \in \mathbb{Z}$.

The diffeomorphism F has continuous stable and unstable foliations \mathcal{W}^s and \mathcal{W}^u . On each stable and unstable manifold a metric d_s and d_u respectively can be defined with the help of the lengths of smooth paths inside a single leaf. We denote for $\eta > 0$ with $W_\eta^s(x)$ the local stable manifold defined by the connected component of x inside $W^s(x) \cap B_\eta(x)$ and with $W_\eta^u(x)$ the analogously defined local unstable manifold of x .

We recall that the local product structure of M implies that for every $\eta_0 > \eta > 0$ there exists δ such that the local stable and unstable manifolds of diameter η intersects in exactly one point whenever $d(x, y) < \delta$, i.e. $W_\eta^s(x) \cap W_\eta^u(y) =: [x, y]$. The point of intersection $[x, y]$ depends continuously on x and y . Further, we utilize the hyperbolicity of F , so we recall that there exist constants $C > 1$ and $0 < \lambda < 1$ such that for all $x \in M$ and $y \in M$ with $d(x, y) < \delta$ and $W_\eta^s(x) \cap W_\eta^u(y) =: [x, y]$ it hold

$$\begin{aligned} d_s(F^n(x), F^n([x, y])) &< C\lambda^n \delta, \text{ for all } n \geq 0, \\ d_u(F^{-n}([x, y]), F^{-n}(y)) &< C\lambda^n \delta, \text{ for all } n \geq 0. \end{aligned}$$

Especially, it holds that $d_s(x, [x, y]) < C\delta$ and $d_u(y, [x, y]) < C\delta$ whenever $d(x, y) < \delta$. Further, it holds that $d(x, [x, y]) \leq d_s(x, [x, y])$ and $d(y, [x, y]) \leq d_u(y, [x, y])$.

We choose $N > 0$ sufficiently big such that $2C^2\lambda^N < 1$ and we denote for simplicity λ^N with Λ . In the following we consider pseudo-orbits of F^N and prove the statement for F^N . We abbreviate F^N with g . If the Shadowing Lemma holds for F^N it also holds for F as the following Lemma shows:

Lemma 1.50. *Let $f : X \rightarrow X$ be a homeomorphism on a compact metric space (X, d) . Then f has the pseudo-orbit tracing property if f^k has the pseudo-orbit orbit tracing property for some $k \in \mathbb{N}$.*

1.3. Dynamics on the leaf space

Proof. Let $\epsilon > 0$ be given. Then there exists $\epsilon > \epsilon_1 > 0$ such that for each ϵ_1 -pseudo orbit $\{x_i\}_{i=0}^k$ it holds $d(f^i(x_0), x_i) < \frac{1}{2}\epsilon$ for all $0 \leq i \leq k$ and $\max_{0 \leq i \leq k} d(f^i(x), f^i(y)) < \frac{1}{2}\epsilon$ whenever $d(x, y) < \epsilon_1$. Let $\epsilon_1 > 0$ as above. Then there exists $\delta_1 > 0$ such that each δ_1 -pseudo orbit of f^k is ϵ_1 -shadowed by some point. We remark that for fixed $\delta_1 > 0$ there exists $\delta > 0$ such that every δ -finite pseudo orbit of f is δ_1 -shadowed by a finite orbit of f . We fix these $\epsilon_1, \delta_1 > 0$ and $\delta > 0$ and Let $\{y_i\}_{i \in \mathbb{Z}}$ be a δ -pseudo orbit of f . Then we define $x_i = y_{ki}$ and fix $i \in \mathbb{Z}$. Then for every $0 \leq j \leq k$ it is $d(f^j(y_{ki}), y_{ki+j}) < \delta_1$ and for $j = k$ it is $d(f^k(y_{ki}), y_{ki+k}) = d(f^k(x_i), x_{i+1}) < \delta_1$. Hence, it is a δ_1 -pseudo orbit of f^k and there exists y such that $d(f^{kj}(y), x_j) = d(f^{kj}(y), y_{kj}) < \epsilon_1$ for $j \in \mathbb{Z}$. On the other hand, since $\{y_{ki+j}\}_{j=0}^k$ is a ϵ_1 -pseudo orbit for f it follows that $d(f^j(y_{ki}), y_{ki+j}) < \frac{\epsilon}{2}$ for $0 \leq j \leq k$ and that $d(f^{ki+j}(y), f^j(y_{ki})) < \frac{\epsilon}{2}$ for $0 \leq j \leq k$. Therefore, it is $d(f^{ki+j}(y), y_{ki+j}) < \epsilon$ for $0 \leq j \leq k$ and since $i \in \mathbb{Z}$ was chosen arbitrarily, we have $d(f^n y, y_n) < \epsilon$ for $n \in \mathbb{Z}$. \square

Now we start the proof of the Shadowing Lemma for $F^N =: g$.

Proof. Given $\epsilon > 0$. We choose $\delta > 0$ such that the local manifolds $W_\eta^u(x)$ and $W_\eta^s(y)$ intersects uniquely whenever $d(x, y) < 2\delta$. Further, we choose $\delta > 0$ sufficiently small such that $\frac{2C^2\delta}{1-\Lambda} < \epsilon$. We consider an arbitrary δ -pseudo orbit $\{x_j\}$ of g .

We construct a sequence $\{z_j\}_{j \geq 0}$ of points $z_j \in M$ such that the accumulation point z of this sequence defines the required orbit $\{g^j z\}_{j \geq 0}$.

Lemma 1.51. *There exists a sequence $\{z_j\}_{j \geq 0}$ such that*

$$(I1) \quad d(x_{j+2}, g^{j+2}(z_j)) < 2\delta,$$

$$(I2) \quad d(x_k, g^k(z_j)) < 2C^2\delta \sum_{i=0}^{j-k} \Lambda^i < \epsilon, \text{ for } 0 \leq k \leq j.$$

If Lemma 1.51 is proved the accumulation point z of the sequence $\{z_j\}_{j \geq 0}$ fulfills

$$d(x_k, g^k(z)) < 2C^2\delta \frac{1}{1-\Lambda} < \epsilon.$$

By shifting the index with $g^{-j}(z_{-j}) =: \tilde{z}_j$ and $x_{-j} =: \tilde{x}_0$ for $j \geq 0$, the negative indices are covered as well with the same construction. Hence, the proof is finished. \square

Proof. [Lemma 1.51] We construct the sequence $\{z_j\}_j$ inductively. We define

$$g(z_0) = W_\eta^u(g(x_0)) \cap W_\eta^s(x_1).$$

The point $g(z_0)$ and hence z_0 is uniquely defined by the choice of $\delta > 0$ and the local product structure of M . Now we claim that properties (I1) and (I2) are fulfilled if we define points z_j recursively for $j \geq 2$ by

$$g^j(z_{j-1}) := W_\eta^u(g^j(z_{j-2})) \cap W_\eta^s(x_j).$$

Lemma 1.52. *If $g^j(z_{j-1}) := W_\eta^u(g^j(z_{j-2})) \cap W_\eta^s(x_j)$ for $j \geq 1$, then properties (I1) and (I2) are fulfilled for all $j \geq 1$.*

So the proof of Lemma 1.52 finishes the proof of Lemma 1.51. \square

Proof. [Lemma 1.52] We prove this by induction. Assuming that the statement is true for $j \geq 1$ we prove it for $j + 1$. Let

$$g^{j+1}(z_j) := W_\eta^u(g^{j+1}(z_{j-1})) \cap W_\eta^s(x_{j+1}).$$

First, we have to show that $g^{j+1}(z_j)$ is a uniquely defined point. Observe that

$$d(g^{j+1}(z_{j-1}), x_{j+1}) < d(g^{j+1}(z_{j-1}), g(x_j)) + d(g(x_j), x_{j+1}). \quad (1.1)$$

By (I1) and the inductive assumption it is $d_s(g^j(z_{j-1}), x_j) < 2C\delta$ and further, it is $g^j(z_{j-1}) \subset W_\eta^s(x_j)$. Hence, it is $d_s(g^{j+1}(z_{j-1}), g(x_j)) < 2C^2\Lambda\delta$. By utilizing $2C^2\Lambda < 1$ and that $\{x_j\}$ is a pseudo-orbit we get for the inequality (1.1)

$$d(g^{j+1}(z_{j-1}), x_{j+1}) < \delta + \delta < 2\delta. \quad (1.2)$$

So, $g^{j+1}(z_j)$ is well-defined as the intersection point of the local stable and unstable manifolds.

We prove now (I2). For $k = j + 1$ it follows

$$\begin{aligned} d(x_{j+1}, g^{j+1}(z_{j+1})) &< d(x_{j+1}, g^{j+1}(z_j)) + d(g^{j+1}(z_j), g^{j+1}(z_{j+1})) \\ &< 2C\delta + d(g^{j+1}(z_j), g^{j+1}(z_{j+1})), \\ &\text{with } g^{j+1}(z_j) \subset W_\eta^s(x_{j+1}). \end{aligned} \quad (1.3)$$

As $g^{j+2}(z_{j+1}) \in W_\eta^u(g^{j+2}(z_j))$ it follows by applying g^{-1} that

$$d_u(g^{j+1}(z_j), g^{j+1}(z_{j+1})) < 2C^2\Lambda\delta.$$

Hence, inequality (1.3) becomes

$$\begin{aligned} d(x_{j+1}, g^{j+1}(z_{j+1})) &< 2C\delta + 2C^2\Lambda\delta, \\ &< 2C^2\delta(1 + \Lambda). \end{aligned} \quad (1.4)$$

1.3. Dynamics on the leaf space

For $k \leq j$ it follows

$$d(x_k, g^k(z_{j+1})) < d(x_k, g^k(z_{k-1})) + \sum_{i=0}^{j-k+1} d(g^k(z_{k+i}), g^k(z_{k+i-1})) \quad (1.5)$$

It is $g^{k+i+1}(z_{k+i}) \in W_\eta^s(g^{k+i+1}(z_{k+i-1}))$ and therefore by applying $g^{-(i+1)}$ we get

$$d_s(g^k(z_{k+i}), g^k(z_{k+i-1})) < 2C^2\delta\Lambda^{i+1}.$$

The inequality (1.5) becomes

$$\begin{aligned} d(x_k, g^k(z_{j+1})) &< 2C\delta + 2C^2\delta \sum_{i=0}^{j-k+1} \Lambda^{i+1} \\ &< 2C\delta + 2C^2\delta \sum_{i=1}^{j-k+2} \Lambda^i \\ &< 2C^2\delta \sum_{i=0}^{j-k+2} \Lambda^i. \end{aligned} \quad (1.6)$$

This proves (I2) for $(j+1)$ and finishes the proof of Lemma 1.52. \square

Difficulties of the Shadowing Lemma for the leaf space

The adaption of the proof of the Shadowing Lemma to the leaf space of the center foliation leads to two main difficulties:

- The points in the pseudo-orbits are now center manifolds. Thus the distance between the leaves may be naturally defined in several ways. Given two nearby leaves, one tries to project one center leaf onto the stable manifold of the other along unstable leaves, as we do for points in the proof of the Shadowing Lemma. That is always possible if the holonomies of the center leaves are trivial. However, even in that case, it is more difficult to compare the stable and unstable distance of these leaves with the projection and the initial distance between the leaves.
- If the holonomies are not trivial, it is not always possible to project a leaf onto the stable manifold of an other along the unstable leaves. One can locally bypass this difficulty by considering holonomy covers. However, the leaves have several lifts to this cover so that the projection is no more uniquely defined.

In order to separate the difficulties we will first present (see Section 1.3.3 below) the Shadowing Lemma assuming that the holonomies are trivial. Then we will solve the difficulties induced by non-trivial finite holonomies in Section 1.3.3.

Compact center foliation with trivial holonomy:

Theorem 1.53 (Shadowing Lemma). *Let $f : M \rightarrow M$ be a partially hyperbolic C^1 -diffeomorphism with a compact invariant center foliation \mathcal{W}^c with trivial holonomy. Then the induced homeomorphism $F : M/\mathcal{W}^c \rightarrow M/\mathcal{W}^c$ on the leaf space has the pseudo-orbit tracing property.*

Recall that we have already proven that the leaf space M/\mathcal{W}^c under the assumptions above is a compact metric space endowed with the Hausdorff metric d_H . As the center holonomy is trivial, the leaf space is a compact topological manifold. Further we showed that the stable and unstable equivalence classes of F coincide with the stable and unstable topological foliations induced by the center-stable and center-unstable foliations \mathcal{W}^{cs} and \mathcal{W}^{cu} in M . We prove Theorem 1.53 following the classical proof of the Shadowing Lemma. There exists a finite open cover $\{U_i\}_{i=1}^k$ of \mathcal{W}^c -saturated neighborhoods with Lebesgue number $\delta > 0$. Then there exist constants $C > 1$ and $0 < \lambda < 1$ such that the following hold:

- (B1) Given a suitable $\eta > 0$. For any $W^c(x), W^c(y) \in M$, if the Hausdorff distance $d_H(W^c(x), W^c(y)) < \delta$, the intersection of $\mathcal{W}^c(W_\eta^s(x))$ and $\mathcal{W}^c(W_\eta^u(y))$ is a unique center leaf $W^c(z)$.
- (B2) There exist local maps $\Delta_s : U_i \times U_i \rightarrow \mathbb{R}$ and $\Delta_u : U_i \times U_i \rightarrow \mathbb{R}$ where $U_i \in \{U_i\}$ such that if $d_H(W^c(x), W^c(y)) < \delta$ it holds that

$$\begin{aligned} \Delta_s(W^c(x), W^c(y)) &< C d_H(W^c(x), W^c(y)) \text{ and} \\ \Delta_u(W^c(x), W^c(y)) &< C d_H(W^c(x), W^c(y)). \end{aligned}$$

- (B3) For any $W^c(x)$ and $W^c(y)$ with $d_H(W^c(x), W^c(y)) < \delta$ one has

$$d_H(W^c(x), W^c(y)) \leq \Delta_s(W^c(x), W^c(y)) + \Delta_u(W^c(x), W^c(y)).$$

Thus,

- if $W^c(y) \subset \mathcal{W}^c(W_\eta^s(x))$, then $d_H(W^c(x), W^c(y)) \leq \Delta_s(W^c(x), W^c(y))$,
- if $W^c(y) \subset \mathcal{W}^c(W_\eta^u(x))$, then $d_H(W^c(x), W^c(y)) \leq \Delta_u(W^c(x), W^c(y))$.

1.3. Dynamics on the leaf space

(B4) For $W^c(z) \subset \mathcal{W}^c(W_\eta^u(y))$, it is implied that

$$\Delta_u(f^{-n}W^c(z), f^{-n}W^c(x)) \leq C\lambda^n\delta \quad \text{for } n \geq 0.$$

(B5) For $W^c(z) \subset \mathcal{W}^c(W_\eta^s(x))$, it is implied that

$$\Delta_s(f^nW^c(z), f^nW^c(x)) \leq C\lambda^n\delta \quad \text{for } n \geq 0.$$

With these properties (B1)-(B5) above we will be able to apply Bowen's proof to show the pseudo-orbit tracing property for the induced homeomorphism F on the leaf space M/\mathcal{W}^c . Hence, we proceed with establishing the enumerated properties above such that we can afterwards adopt Bowen's proof directly to our setting.

Proving the properties (B1)-(B5). We need several Lemmata to obtain the five properties (B1)-(B5). Denote with q the codimension of \mathcal{W}^c :

Lemma 1.54. *Let \mathcal{W}^c be a compact foliation with trivial holonomy of a compact manifold M . Then there exists a finite open cover $\{U_i\}_{i=1}^k$ of M of \mathcal{W}^c -saturated neighborhoods such that U_i is homeomorphic to the trivially foliated product $W^c(x) \times T$ where $W^c(x) \subset U_i$ and T is a smoothly embedded q -manifold transverse to $W^c(x)$ at x . Further, there exists $\delta_1 > 0$ such that for every center leaf $W^c(x)$ there exists $i \in \{1, \dots, k\}$ such that $W^c(x) \subset U_i$ and $W^c(y) \subset U_i$ whenever $d_H(W^c(x), W^c(y)) < \delta_1$.*

Proof. As the center foliation \mathcal{W}^c is a compact foliation with trivial holonomy and M is a compact manifold, the Reeb Stability Theorem implies that there exists a finite cover $\{U_i\}_{i=1}^k$ of M of \mathcal{W}^c -saturated trivializing neighborhoods U_i , such that $U_i \simeq W^c(x) \times T$ where $W^c(x) \subset U_i$ and T is a smoothly embedded manifold transverse to $W^c(x)$ at x . Every leaf $W^c(y) \subset U_i$ is homeomorphic to $W^c(x)$. As M is compact and U_i are \mathcal{W}^c -saturated neighborhoods there exists a Lebesgue number $\delta_1 > 0$ with respect to the compact metric space $(M/\mathcal{W}^c, d_H)$ such that for every center leaf $W^c(x)$ there exists $i \in \{1, \dots, k\}$ such that $W^c(x) \subset U_i$ and $W^c(y) \subset U_i$ whenever $d_H(W^c(y), W^c(x)) < \delta_1$. \square

In the next lemma we prove the existence of a second appropriate cover such that each open set is trivially foliated as a product.

Lemma 1.55. *Let $f : M \rightarrow M$ be a partially hyperbolic C^1 -diffeomorphism with a f -invariant compact center foliation \mathcal{W}^c with trivial holonomy. Then there exists a finite open cover $\{V_i\}_{i=1}^l$ of \mathcal{W}^c -saturated sets such that every*

set V_i is homeomorphic to $W^c(x) \times T$ and T is a smoothly embedded manifold transverse to $W^c(x)$ and trivially foliated as a product by the induced stable and unstable foliations on T . Further, there exists $\delta > 0$ such that for every center leaf $W^c(x)$ there exists $i \in \{1, \dots, l\}$ such that $W^c(x) \subset V_i$ and $W^c(y) \subset V_i$ whenever $d_H(W^c(x), W^c(y)) < \delta$.

Proof. Let $\{U_i\}_{i=1}^k$ be the cover of Lemma 1.54. Let $W^c(x) \subset U_i$. As f is dynamically coherent according to Theorem 1.24, we find a smaller W^c -saturated neighborhood $V_i \subset U_i$ such that the transversal T restricted to V_i is trivially bifoliated by stable and unstable foliations as a product. As M is compact, we can cover M by a finite number of such W^c -saturated neighborhoods. With the same argument as in Lemma 1.54 there exists a Lebesgue number $\delta > 0$ for this cover with the required properties. \square

The next lemma provides the announced property (B1):

Lemma 1.56. *There exists $\mu > 0$ and $\eta > 0$ such that*

- *For all $x, y \in M$ if $d_H(W^c(x), W^c(y)) \leq \mu$ then there exists a unique $W^c(z_{x,y})$ such that $W^c(z_{x,y}) = \mathcal{W}^c(W_\eta^s(x)) \cap \mathcal{W}^c(W_\eta^u(y))$.*
- *For every $x' \in W^c(x), y' \in W^c(y)$ it is $W^c(z_{x,y}) = W^c(z_{x',y'})$.*

Proof. Let $\{V_i\}$ and $\delta > 0$ be given as in Lemma 1.55. Given $x, y \in M$ with $d_H(W^c(x), W^c(y)) < \delta$ and let V_i such that $W^c(x), W^c(y) \subset V_i$. Then for every $\xi \in W^c(x)$ there exists $\zeta \in W^c(y)$ such that $d(\xi, \zeta) < \delta$. Because of the product structure of V_i there exists $C > 1$ such that the intersection of $\mathcal{W}^c(W_{C\delta}^s(\xi)) \cap W_{C\delta}^u(\zeta) = z_{\xi,\zeta}$ is unique. It is $W^c(z_{\xi,\zeta}) \subset \mathcal{W}^c(W_{C\delta}^s(\xi)) \cap \mathcal{W}^c(W_{C\delta}^u(\zeta))$, and therefore - as $C\delta > d_s(\xi, z_{\xi,\zeta}) \geq d(\xi, z_{\xi,\zeta}) - W^c(z_{\xi,\zeta}) \subset \mathcal{W}^c(B_{C\delta}(\xi))$. For $\delta > 0$ there exists $\eta > 0$ such that $\mathcal{W}^c(B_\eta(\xi)) \subset B_H(W^c(\xi), \delta) = B_H(W^c(x), \delta)$ and hence, we choose $\mu \leq \delta$ such that $\eta \leq C\mu$ and such that this inclusion holds. Then we repeat the construction above for $d_H(W^c(x), W^c(y)) < \mu$ and obtain $W^c(z_{\xi,\zeta}) \subset V_i$. Take any pair of points $x' \in W^c(x), y' \in W^c(y)$ such that $d(x', y') < \mu$ and assume that $W^c(z_{x',y'}) \neq W^c(z_{\xi,\zeta})$. As they are both equally contained in V_i there exists a su -path $\gamma = \gamma_s \cup \gamma_u$ from ξ to $W^c(z_{x',y'})$ with $l(\gamma) < C\mu$. As $W^c(z_{x',y'}) \not\subset \mathcal{W}^c(W_\eta^s(\xi))$ it is $l(\gamma_u) > 0$. By taking f^n -iterates the distance between ξ and $W^c(z_{x',y'})$ would grow while the distance between x' and $W^c(z_{x',y'})$ shrinks contradicting the property above that two points on two center leaves sufficiently close to each other forces the Hausdorff distance to be small, too, assuming compact leaves with finite holonomy. Hence, $W^c(z_{x',y'}) = W^c(z_{\xi,\zeta})$ can be concluded. \square

Notation:

- We denote with $W_{loc}^{cs}(x) = \mathcal{W}^c W_\eta^s(x)$ and with $W_{loc}^{cu}(x) = \mathcal{W}^c W_\eta^u(x)$ obtained in the Lemma above. This notation depends a priori from the point x chosen in the leaf. However, the second item of the lemma tells us that this ambiguity does not lead to an ambiguity of the intersection leaf $W^c(z_{x,y})$ whenever one consider leaves at Hausdorff distance less than μ .
- We call *stable path* and we denote with $\gamma_s : [0, 1] \rightarrow M$ a smooth path which lies entirely inside a single stable leaf $W^s(\gamma_s(0))$. Analogously, we define an *unstable path* and denote it with γ_u .
- The distance d_s inside a stable leaf is defined as follows for any $p, q \in W^s(x)$:

$$d_s(p, q) := \inf \{l(\gamma_s) \mid \gamma_s(0) = p, \gamma_s \subset W_{loc}^s(p), \gamma_s(1) = q\}.$$

Analogously, we define the distance d_u inside an unstable leaf.

- Therefore, we can define the stable distance between a point $p \in W^c(x)$ and a sufficiently close center leaf $W^c(y)$ by

$$d_s(p, W^c(y)) := \inf \{l(\gamma_s) \mid \gamma_s \subset W_{loc}^s(x), \gamma_s(0) = p, \gamma_s(1) \in W_{loc}^s(p) \cap W_{loc}^{cu}(y)\}.$$

In the same way, the distance d_u inside an unstable leaf is defined.

Now we can formulate the following Lemma:

Lemma 1.57. *Let $f : M \rightarrow M$ be a partially hyperbolic C^1 -diffeomorphism with a compact invariant center foliation \mathcal{W}^c with trivial holonomy. Fix a constant $\delta > 0$ as in Lemma 1.55 (associated to a finite cover $\{V_i\}_{i=1}^l$). Then there exists a constant $C > 1$ such that for any two center leaves $W^c(x), W^c(y)$ with $d_H(W^c(x), W^c(y)) < \delta$ it is*

$$\begin{aligned} \max_{p \in W^c(x)} d_s(p, W^c(y)) &\leq C d_H(W^c(x), W^c(y)) \text{ and} \\ \max_{p \in W^c(x)} d_u(p, W^c(y)) &\leq C d_H(W^c(x), W^c(y)). \end{aligned}$$

Proof. We fix a $\delta > 0$ and a finite cover $\{V_i\}$ as in Lemma 1.55. We consider two center leaves $W^c(x), W^c(y) \subset V_i$ with $d_H(W^c(x), W^c(y)) < \delta$. Recall that $V_i \simeq W^c(x) \times T$ and that the transverse manifold T is subfoliated as

a product by the local stable and unstable foliations \mathcal{W}_{loc}^s and \mathcal{W}_{loc}^u . Hence, the whole neighborhood V_i is trivially foliated by the three foliations \mathcal{W}_{loc}^s , \mathcal{W}_{loc}^u and \mathcal{W}^c . As $d_H(W^c(x), W^c(y)) < \delta$, for every $p \in W^c(x)$ there exists a unique intersection point $z_p \in W_{loc}^s(p) \cap W_{loc}^{cu}(y)$ by the local product structure. Therefore we can calculate $d_s(p, z_p) = d_s(p, W^c(y))$. By the transversality of the stable and unstable foliations, depending on the angle of intersection of both foliations, there exists a constant $C > 1$ such that $d_s(p, z_p) \leq Cd(p, z_p) \leq Cd_H(W^c(x), W^c(y))$ for all $p \in W^c(x)$. As V_i is trivially foliated as a product, the center leaves are all compact and the distance d_s varies continuously with $p \in W^c(x)$ the maximum is also bounded by $Cd_H(W^c(x), W^c(y))$. \square

Remark 1.58. *The constant $C > 1$ in Lemma 1.57 above depends on the angle of intersection of the local stable and unstable foliation. The closer the angle is to $\frac{\pi}{2}$ the closer to 1 the constant C can be chosen. It is always possible to choose a metric, equivalent to the canonical smooth Riemannian metric on M , but not differentiable, such that the stable and unstable foliations intersect orthogonally. By approaching with δ to zero, i.e. by choosing a sufficiently small foliated neighborhood, the local diffeomorphism from the transversal T to an open disk \mathbb{D}^q in \mathbb{R}^q gets closer and closer to an isometry with respect to the original metric and hence, the constant C can be chosen arbitrarily close to 1.*

We need the following lemma to obtain later well-defined maps Δ_s and Δ_u :

Lemma 1.59. *Let $f : M \rightarrow M$ be a partially hyperbolic C^1 -diffeomorphism with a compact invariant center foliation \mathcal{W}^c with trivial holonomy. Let $\delta > 0$ be sufficiently small such that every local center-stable and local center-unstable leaf inside a trivializing neighborhood intersects exactly once. Then the constant $C > 1$ of Lemma 1.57 does not depend on the choice of the finite cover $\{V_i\}_{i=1}^k$.*

Proof. We choose two arbitrary finite covers $\{V_i\}_{i=1}^k$ and $\{W_j\}_{j=1}^l$ as in Lemma 1.55 such that $W^c(x), W^c(y) \subset V_i$ and $W^c(x), W^c(y) \subset W_j$ for some i and j whenever $d_H(W^c(x), W^c(y)) < \delta$. Fix two leaves $W^c(x), W^c(y)$ with $d_H(W^c(x), W^c(y)) < \delta$. Then it follows that $W^c(x), W^c(y) \subset V_i$ and $W^c(x), W^c(y) \subset W_j$ for some i and j . As the holonomy is trivial, the intersection $V_i \cap W_j$ is a trivializing neighborhood and $W^c(y), W^c(x) \subset V_i \cap W_j$. So, applying Lemma 1.57 to the cover $\{V_i\}$, it follows

$$\max_{p \in W^c(x)} d_s(p, W^c(y)) < Cd_H(W^c(x), W^c(y)).$$

1.3. Dynamics on the leaf space

As $d_s(p, W^c(y)) = d_s(p, W_{loc}^s(p) \cap W_{loc}^{cu}(y))$ and $W_{loc}^{cu}(y), W_{loc}^{cs}(x) \subset V_i \cap W_j$ by the definition of the local \mathcal{W}^c -saturated stable and unstable manifolds, all paths γ_s taken for defining d_s lie inside $V_i \cap W_j$, and hence the maximum in both covers is equally bounded by $Cd_H(W^c(x), W^c(y))$. \square

Let $W^c(x), W^c(y)$ be two center leaves with $d_H(W^c(x), W^c(y)) < \delta$ then we define the local functions Δ_u and Δ_s as following:

$$\Delta_u(W^c(x), W^c(y)) := \max \left\{ \max_{p \in W^c(x)} d_u(p, W^c(y)), \max_{q \in W^c(y)} d_u(W^c(x), q) \right\}.$$

The local function Δ_u along strong stable leaves is defined in an analogous way. Due to Lemma 1.57 and Lemma 1.59 these local functions along strong unstable and strong stable leaves of two center leaves sufficiently close are well-defined.

As a direct consequence of Lemma 1.57 one gets the following corollary which provides our announced property (B2):

Corollary 1.60. *For any two center leaves $W^c(x), W^c(y)$ with $d_H(W^c(x), W^c(y)) < \delta$ it is*

$$\begin{aligned} \Delta_s(W^c(x), W^c(y)) &\leq Cd_H(W^c(x), W^c(y)), \quad \text{and} \\ \Delta_u(W^c(x), W^c(y)) &\leq Cd_H(W^c(x), W^c(y)). \end{aligned}$$

Property (B3) is now given by the next lemma:

Lemma 1.61. *For any pair of center leaves $W^c(x), W^c(y) \subset M$ with $d_H(W^c(x), W^c(y)) < \delta$ it is*

$$d_H(W^c(x), W^c(y)) \leq \Delta_s(W^c(x), W^c(y)) + \Delta_u(W^c(x), W^c(y)).$$

Thus, if $W^c(y) \subset \mathcal{W}^c(W_{loc}^s(x))$ and $d_H(W^c(x), W^c(y)) < \delta$, then $d_H(W^c(x), W^c(y)) \leq \Delta_s(W^c(x), W^c(y))$, and the analog holds for Δ_u .

Proof. By the definition of d_H and Δ_s it is easily seen that the statement follows from the fact that the distance inside the manifold $d(p, q)$ is always less equal than the distance inside a leaf $d_s(p, q)$, i.e. $d(p, q) \leq d_s(p, q)$ for all $p, q \in W_{loc}^s(x)$. \square

We have now proved the existence of maps Δ_s, Δ_u and their required properties of the maps. In the following corollary we prove the remaining properties (B4) and (B5) in order to proceed with Bowen's proof of the Shadowing Lemma:

Corollary 1.62. *Fix an arbitrary cover $\{V_i\}$ and $\delta > 0$ as in Lemma 1.55. Then there exist constants $C > 1$ and $0 < \lambda < 1$ such that the following items hold:*

1. For $W^c(z) \subset W_{loc}^{cu}(x)$, it is implied that

$$\Delta_u(f^{-n}W^c(z), f^{-n}W^c(x)) \leq C\lambda^n\delta \quad \text{for } n \geq 0.$$

2. For $W^c(z) \subset W_{loc}^{cs}(x)$, it is implied that

$$\Delta_s(f^nW^c(z), f^nW^c(x)) \leq C\lambda^n\delta \quad \text{for } n \geq 0.$$

Proof. The two items are directly implied by the definition of the distances Δ_u and Δ_s with the help of stable and unstable paths and the partial hyperbolicity of f . \square

Adapting Bowen's proof of the Shadowing Lemma. With the Lemmata 1.54 - 1.61 and Corollary 1.62 we are now able to follow the proof by Bowen. We call a pseudo-orbit with respect to F in the leaf space M/\mathcal{W}^c a \mathcal{W}^c -pseudo orbit if it is lifted to M . We show that for every $\epsilon > 0$ there exists $\delta > 0$ such that for every δ - \mathcal{W}^c -pseudo-orbit $\{W^c(x_i)\}$ of F with $d_H(W^c(f(x_i)), W^c(x_{i+1})) < \delta$ there is $W^c(w) \subset M$ such that $d_H(W^c(f^i w), W^c(x_i)) < \epsilon$. Firstly, we pick an integer $N > 0$ such that $\lambda^N 2C^2 < 1$, for simplicity we denote λ^N with Λ and f^N with g . We show that any \mathcal{W}^c -pseudo-orbits of g can be shadowed by an orbit of center leaves. As we showed in Lemma 1.50 this implies that any \mathcal{W}^c -pseudo-orbit of f can be shadowed by an orbit of center leaves.

Given $\epsilon > 0$ we choose $\delta > 0$ such that $\frac{2C^2\delta}{1-\Lambda} < \epsilon$. Assume $\delta > 0$ small enough such that $W_{loc}^{cs}(x)$ and $W_{loc}^{cu}(y)$ intersect uniquely whenever $d_H(W^c(x), W^c(y)) < 2\delta$.

Let $\{W^c(x_i)\}_{i \in \mathbb{Z}}$ be a δ - \mathcal{W}^c -pseudo orbit for $g =: f^N$, i.e. it is $d_H(W^c(g(x_i)), W^c(x_{i+1})) < \delta$ for $i \in \mathbb{Z}$, hence, our Lemmata above can be applied. We have to show that there exists a orbit $\{W^c(g^i z)\}_{i \in \mathbb{Z}}$ of center leaves that ϵ -shadows this δ - \mathcal{W}^c -pseudo-orbit.

For this reason we construct for every integer $j \geq 0$ a center leaf $W^c(z_j)$ such that its g^k -iterates are ϵ -close to $W^c(x_k)$ for all $0 \leq j \leq k$. Then the accumulation leaf $W^c(z)$ of the sequence $\{W^c(z_j)\}_{j \geq 0}$ fulfills

$$d_H(g^i W^c(z), W^c(x_i)) \leq \epsilon \quad \text{for } i \in \mathbb{N}.$$

By shifting the indexes we achieve that the whole orbit of $W^c(z)$ ϵ -shadows the δ -pseudo orbit $\{W^c(x_i)\}$. Hence, we start with the following Lemma:

1.3. Dynamics on the leaf space

Lemma 1.63. *For every integer $j \geq 0$ there exists a center leaf $W^c(z_j) \subset M$ such that*

$$d_H(g^k W^c(z_j), W^c(x_k)) \leq \epsilon \quad \text{for } 0 \leq k \leq j.$$

Proof. [Lemma 1.63] We construct the sequence $\{W^c(z_j)\}_{j \geq 0}$ inductively. It holds that $d_H(gW^c(x_0), W^c(x_1)) < \delta$. Therefore the intersection leaf

$$W^c(z_0) := W_{loc}^{cu}(g(x_0)) \cap W_{loc}^{cs}(x_1)$$

is well-defined.

Claim: We claim that for every $j \geq 0$ there exists a center leaf $W^c(z_j)$ such that

$$(I1) \quad d_H(W^c(g^{j+2}(z_j)), W^c(x_{j+2})) < 2\delta,$$

$$(I2) \quad d_H(W^c(g^k(z_j)), W^c(x_k)) < 2C^2\delta \left(\sum_{i=0}^{j-k} \Lambda^i \right) < \epsilon \quad \text{for } 0 \leq k \leq j.$$

We show the Claim by induction. The inductive step is proved inside the following Lemma:

Lemma 1.64. *For $j \geq 2$ let the center leaf $W^c(z_{j-1})$ be defined by*

$$g^j(W^c(z_{j-1})) = W_{loc}^{cu}(g^j(z_{j-2})) \cap W_{loc}^{cs}(x_j).$$

Then the center leaf $W^c(z_{j-1})$ fulfills the following properties

$$(I1) \quad d_H(W^c(g^{j+1}(z_{j-1})), W^c(x_{j+1})) < 2\delta$$

$$(I2) \quad d_H(W^c(g^k(z_{j-1})), W^c(x_k)) < 2C^2\delta \left(\sum_{i=0}^{j-k} \Lambda^i \right) \quad \text{for } 0 \leq k \leq j-1.$$

Then the properties 1.3.3 and 1.3.3 give us

$$d_H(g^k W^c(z_j), W^c(x_k)) \leq \frac{2C^2\delta}{1-\Lambda} < \epsilon$$

for $0 \leq k \leq j$ as required and Lemma 1.63 is proved. \square

Hence, it remains the proof of the inductive step in Lemma 1.64:

Proof. [Lemma 1.64] First, we have to show that $W^c(z_j)$ can be defined by

$$g^{j+1}(W^c(z_j)) = W_{loc}^{cu}(g^{j+1}(z_{j-1})) \cap W_{loc}^{cs}(x_{j+1}).$$

Observe that

$$\begin{aligned} d_H(W^c(g^{j+1}(z_{j-1})), W^c(x_{j+1})) &< d_H(W^c(g^{j+1}(z_{j-1})), W^c(g(x_j))) \\ &\quad + d_H(W^c(g(x_j)), W^c(x_{j+1})). \end{aligned} \quad (1.7)$$

By (I1) and the inductive assumption it is $\Delta_s(W^c(g^j(z_{j-1})), W^c(x_j)) < 2C\delta$ and further, it is $W^c(g^j(z_{j-1})) \subset W_{loc}^{cs}(x_j)$. Hence, it is $\Delta_s(W^c(g^{j+1}(z_{j-1})), W^c(g(x_j))) < 2C^2\Lambda\delta$. By utilizing $2C^2\Lambda < 1$ and that $\{W^c(x_i)\}$ is a δ -pseudo orbit the inequality (1.7) becomes

$$d_H(W^c(g^{j+1}(z_{j-1})), W^c(x_{j+1})) < \delta + \delta < 2\delta.$$

As $\delta > 0$ is chosen sufficiently small such that this intersection is unique we obtain a unique leaf $W^c(z_j)$. We prove now (I2). For $k = j + 1$ it follows

$$\begin{aligned} d_H(W^c(x_{j+1}), W^c(g^{j+1}(z_{j+1}))) &< d_H(W^c(x_{j+1}), W^c(g^{j+1}(z_j))) \\ &\quad + d_H(W^c(g^{j+1}(z_j)), W^c(g^{j+1}(z_{j+1}))) \\ &< 2C\delta + d(W^c(g^{j+1}(z_j)), W^c(g^{j+1}(z_{j+1}))), \\ &\quad \text{with } W^c(g^{j+1}(z_j)) \subset W_{loc}^{cs}(x_{j+1}). \end{aligned} \quad (1.8)$$

As $W^c(g^{j+2}(z_{j+1})) \in W_{loc}^{cu}(g^{j+2}(z_j))$ it follows by applying g^{-1} that

$$\Delta_u(W^c(g^{j+1}(z_j)), W^c(g^{j+1}(z_{j+1}))) < 2C^2\Lambda\delta.$$

Hence, inequality (1.8) becomes

$$\begin{aligned} d_H(W^c(x_{j+1}), W^c(g^{j+1}(z_{j+1}))) &< 2C\delta + 2C^2\Lambda\delta, \\ &< 2C^2\delta(1 + \Lambda). \end{aligned} \quad (1.9)$$

For $k \leq j$ it follows

$$\begin{aligned} d_H(W^c(x_k), W^c(g^k(z_{j+1}))) &< d_H(W^c(x_k), W^c(g^k(z_{k-1}))) \\ &\quad + \sum_{i=0}^{j-k+1} d_H(W^c(g^k(z_{k+i})), W^c(g^k(z_{k+i-1}))) \end{aligned} \quad (1.10)$$

It is $W^c(g^{k+i+1}(z_{k+i})) \in W_{loc}^{cu}(g^{k+i+1}(z_{k+i-1}))$ and therefore by applying $g^{-(i+1)}$ we get

$$\Delta_s(W^c(g^k(z_{k+i})), W^c(g^k(z_{k+i-1}))) < 2C^2\delta\Lambda^{i+1}.$$

The inequality (1.10) becomes

$$\begin{aligned}
 d_H(W^c(x_k), W^c(g^k(z_{j+1}))) &< 2C\delta + 2C^2\delta \sum_{i=0}^{j-k+1} \Lambda^{i+1} \\
 &< 2C\delta + 2C^2\delta \sum_{i=1}^{j-k+2} \Lambda^i \\
 &< 2C^2\delta \sum_{i=0}^{j-k+2} \Lambda^i. \tag{1.11}
 \end{aligned}$$

This finishes the proof of Lemma 1.64. \square

Compact center foliation with non-trivial finite holonomy.

Theorem 1.65 (Shadowing Lemma). *Let $f : M \rightarrow M$ be a partially hyperbolic C^1 -diffeomorphism with a compact invariant center foliation \mathcal{W}^c with finite holonomy. Then the induced homeomorphism $F : M/\mathcal{W}^c \rightarrow M/\mathcal{W}^c$ has the pseudo-orbit tracing property.*

We want to prove the case of a compact center foliation with finite holonomy in an analogous way as the case of a compact center foliation with trivial holonomy by recovering the five required properties (B1)-(B5) for the proof above in the new setting. The main point is to define new local functions Δ_s and Δ_u and suitable distance Δ_H between center leaves such that the properties (B1)-(B5) are fulfilled.

There exists a finite open cover $\{U_i\}_{i=1}^k$ of \mathcal{W}^c -saturated neighborhoods and $\delta > 0$. Then there exist constants $C > 1$ and $0 < \lambda < 1$ such that the following hold:

(B1) There is a distance Δ_H on M/\mathcal{W}^c topologically equivalent to d_H , and $\eta > 0$ with the following properties:

For any $W^c(x), W^c(y) \subset M$, if $\Delta_H(W^c(x), W^c(y)) < \delta$, the intersection of $\mathcal{W}^c(W_\eta^s(x))$ and $\mathcal{W}^c(W_\eta^u(y))$ contains a center leaf $W^c(z_{x,y})$ with

$$\begin{aligned}
 \Delta_H(W^c(z_{x,y}), W^c(x)) &\leq C\Delta_H(W^c(x), W^c(y)) \text{ and} \\
 \Delta_H(W^c(z_{x,y}), W^c(y)) &\leq C\Delta_H(W^c(x), W^c(y))
 \end{aligned}$$

(B2) There exist local maps $\Delta_s : U_i \times U_i \rightarrow \mathbb{R}$ and $\Delta_u : U_i \times U_i \rightarrow \mathbb{R}$ where $U_i \in \{U_i\}$ such that if $\Delta_H(W^c(x), W^c(y)) < \delta$ it holds that

$$\begin{aligned}
 \Delta_s(W^c(x), W^c(z_{x,y})) &< C\Delta_H(W^c(x), W^c(y)) \text{ and} \\
 \Delta_u(W^c(z_{x,y}), W^c(y)) &< C\Delta_H(W^c(x), W^c(y)),
 \end{aligned}$$

where $W^c(z_{x,y})$ is the intersection leaf as in (B1).

(B3) For any $W^c(x)$ and $W^c(y)$ with $\Delta_H(W^c(x), W^c(y)) < \delta$ one has

$$\Delta_H(W^c(x), W^c(y)) \leq \Delta_s(W^c(x), W^c(z_{x,y})) + \Delta_u(W^c(z_{x,y}), W^c(y))$$

Thus,

if $W^c(y) \subset \mathcal{W}^c(W_\eta^s(x))$, then $d_H(W^c(x), W^c(y)) \leq \Delta_s(W^c(x), W^c(y))$,

if $W^c(y) \subset \mathcal{W}^c(W_\eta^u(x))$, then $d_H(W^c(x), W^c(y)) \leq \Delta_u(W^c(x), W^c(y))$.

(B4) For $W^c(z) \subset \mathcal{W}^c(W_\eta^u(y))$, it is implied that

$$\Delta_u(f^{-n}W^c(z), f^{-n}W^c(x)) \leq C\lambda^n\delta \quad \text{for } n \geq 0.$$

(B5) For $W^c(z) \subset \mathcal{W}^c(W_\eta^s(x))$, it is implied that

$$\Delta_s(f^nW^c(z), f^nW^c(x)) \leq C\lambda^n\delta \quad \text{for } n \geq 0.$$

Difficulties of non-trivial finite holonomies. In this paragraph we recall the local picture of a compact foliation with finite holonomy and explain why the proof in the case of trivial holonomies has to be changed.

Every compact center leaf with a finite holonomy group has, as a consequence of the Reeb Stability Theorem, a saturated neighborhood which is homeomorphic to a flat bundle foliation (cp. Section 1.1). This neighborhood has a finite holonomy cover such that the lifted center leaves have only trivial holonomy. The first idea might be to prove the Shadowing Lemma by proving it in these local holonomy covers where the holonomy is trivial. But the example as described in Example 1.12 and 1.39 illustrates the difficulties which arise when trying to adapt the proof of the Shadowing Lemma in this way. First, the intersection leaf between local center-unstable and local center-stable leaves with non-trivial holonomy is not unique. Lifting it to the local holonomy cover does not remove the difficulties because there are usually several lifted leaves in the holonomy cover and its number differ depending on the order of the holonomy group. Further, we have to assure that close lifted leaves in the cover remains close in the base. It is necessary to define a new distance between center leaves which resolves this problem. To obtain unstable and stable distances, we have to choose well the lifted center leaves in order to be able to define projections along stable and unstable leaves which are a priori not well-defined. We start with the definition of a new metric Δ_H between center leaves which is locally invariant under covering maps of holonomy covers and therefore it allows us to work locally in the holonomy covers where the lifted center leaves have trivial holonomy.

Definition of a new metric Δ_H between center leaves adapted to holonomy covers. First, we show the existence of appropriate covers.

Notation: We denote a \mathcal{W}^c -saturated ball with respect to the Hausdorff metric d_H by

$$B_H(W^c(x), \delta) := \{W^c(y) \subset M \mid d_H(W^c(x), W^c(y)) < \delta\}$$

and a ball with respect to the usual Riemannian metric d on M by

$$B_\delta(x) := \{y \in M \mid d(x, y) < \delta\}.$$

Lemma 1.66. *Let \mathcal{W}^c be a compact foliation with finite holonomy of a compact manifold M . Then there exists a finite open cover $\{U_i\}_{i=1}^k$ of \mathcal{W}^c -saturated sets such that:*

1. *Let Hol denote the holonomy group of maximal order inside U_i . There exist covering maps $q_i : \tilde{U}_i \rightarrow U_i$ such that $\tilde{U}_i / \text{Hol} = U_i$ and \tilde{U}_i is trivially foliated as a product by the lifted center leaves. Every lift $\tilde{W}^c(x) \subset q_i^{-1}W^c(x)$ has only trivial holonomy.*
2. *There exists $\delta_1 > 0$ such that for all $W^c(x)$ there exists $i \in \{1, \dots, k\}$ such that $B_H(W^c(x), \delta_1) \subset U_i$.*

Proof. The statement is a direct implication of the Reeb Stability Theorem 1.6, the compactness of M and the existence of a Lebesgue number for a finite cover of a compact manifold. \square

We call such a cover $\{U_i, q_i\}$ with finite coverings $q_i : \tilde{U}_i \rightarrow U_i$ as above a *holonomy cover* of M . We lift the Riemannian metric d on M to \tilde{d} on these local covers \tilde{U}_i in order to define our new distance Δ_H between center leaves in M . If two points $x, y \in \tilde{U}_i$ are in the same connected component, the metric \tilde{d} is exactly the Riemannian metric d . Otherwise, we set $\tilde{d}(x, y) := 1$. There exist $\eta > 0$ such that for every two points $x, y \in \tilde{U}_i$ with $\tilde{d}(x, y) < \eta$ the covering map p is then an isometry with respect to this metric \tilde{d} on \tilde{U} and d on U . We denote \tilde{d} on \tilde{U}_i for simplicity with d again. We define a metric \tilde{d}_H between lifted center leaves in \tilde{U}_i in the usual manner as Hausdorff metric with the help of \tilde{d} and we denote it by d_H again. We define the diameter of a \mathcal{W}^c -saturated set $A \subset M$ by $\text{diam}_H A := \sup \{d_H(W^c(x), W^c(y)) \mid W^c(x), W^c(y) \subset A\}$.

Lemma 1.67. *Let $f : M \rightarrow M$ be a C^1 -diffeomorphism with a f -invariant compact center foliation \mathcal{W}^c with finite holonomy and $\{U_i, q_i\}$ a holonomy cover with Lebesgue number $\delta_1 > 0$ as in Lemma 1.66. Then there exists a finite holonomy cover $\{V_i, p_i\}_{i=1}^l$ with the following properties:*

1. The $\text{diam}_H V_i < \frac{1}{2}\delta_1$ for every $i = 1, \dots, l$ is less than $\frac{1}{2}\delta_1$. There exists j such that V_i injects trivially into U_j such that $q_j|_{\tilde{V}_i} = p_i$ defines the covering map of V_i , and V_i is relatively compact inside U_j .
2. Every lift \tilde{V}_i is trivially foliated as a product by the lifted local stable, unstable and center foliations.
3. There exists $\delta_0 > 1$ such that for every $W^c(x) \subset M$ there exists $i \in \{1, \dots, l\}$ such that $B_H(W^c(x), \delta_0) \subset V_i$.

Proof. We just have to shrink the precedent cover $\{U_i\}$ in the appropriate way. By the dynamical coherence, established in Theorem 1.26, we know that there exists a neighborhood V_i with the required properties. So we can construct such a finite cover and hence, there exists a Lebesgue number δ_0 for this finite cover of a compact manifold. \square

Remark 1.68. • By the construction of the holonomy cover $\{V_i\}$ with respect to $\{U_i\}$ we can conclude that for every neighborhood V_i there exists j such that the boundary of \tilde{V}_i is far from the boundary of U_j as $\tilde{V}_i \subset B_H(W^c(x), \frac{1}{2}\delta_1) \subset B_H(W^c(x), \delta_1) \subset U_j$ for some $W^c(x) \subset V_i$.

- For every lifted center leaves $\tilde{W}^c(x), \tilde{W}^c(y)$ of $W^c(x), W^c(y) \subset V_i$ it holds that

$$d_H(\tilde{W}^c(x), \tilde{W}^c(y)) \geq d_H(W^c(x), W^c(y)).$$

If $\tilde{W}^c(x), \tilde{W}^c(y) \subset \tilde{V}_i$ are in the same connected component, their distance is greater or equal by the definition of d_H on \tilde{V}_i , otherwise it is by definition $d_H(\tilde{W}^c(x), \tilde{W}^c(y)) = 1$ and therefore greater than $d_H(W^c(x), W^c(y)) < \text{diam}_H V_i < \frac{1}{2}\delta_1$.

- Therefore and by the finiteness of the cover, there exists $\delta_1^* > 0$ such that for every $x \in M$ and $i \in \{1, \dots, l\}$ with $B_H(W^c(x), \delta_0) \subset V_i$ it follows that $B_H(\tilde{W}^c(x), \delta_1^*) \subset \tilde{V}_i$ and $B_H(\tilde{W}^c(x), \delta_1^*) \cap \partial\tilde{V}_i = \emptyset$.

Lemma 1.69. Let $\{U_i, q_i\}$ be a holonomy cover as in Lemma 1.66 and $\{V_i, p_i\}_{i=1}^l$ and $\delta_0 > 0$ as in Lemma 1.67.

For every $\delta^* > 0$ with $\delta^* < \delta_1^*$ there exists $0 < \delta < \frac{1}{2}\delta_0$, such that for all $x \in M$ and $i \in \{1, \dots, l\}$ with $B_H(W^c(x), \delta_0) \subset V_i$, it holds that for every $\tilde{W}^c(x) \subset p_i^{-1}W^c(x)$ and for every $W^c(y) \subset B_H(W^c(x), \delta)$ there exists $\tilde{W}^c(y) \subset p_i^{-1}W^c(y)$ such that $\tilde{W}^c(y) \subset B_H(\tilde{W}^c(x), \delta^*)$.

Proof. We recall that we showed in Lemma 1.9 that for every compact foliation \mathcal{F} with finite holonomy the following holds: For every $x \in M$ and

1.3. Dynamics on the leaf space

every $\delta^* > 0$ there exists $\delta > 0$ such that $\mathcal{F}(B_\delta(x)) \subset B_H(F(x), \delta^*)$ where $F(x)$ denotes the leaf through x . This is a direct consequence of the Reeb Stability Theorem.

A priori we are now in a non-compact situation inside a local neighborhood V_i . But by the choice of our cover $\{V_i\}$, every V_i is relatively compact inside a larger neighborhood U_j of the holonomy cover $\{U_i\}$. Hence, \bar{V}_i is a compact space foliated by the compact foliation \mathcal{W}^c with finite holonomy. Further, by the choice of δ_0 for every $0 < \delta < \frac{1}{2}\delta_0$ the ball $B_H(W^c(x), \delta) \subset V_i$ and bounded away from the boundary of V_i . For every $W^c(x) \subset V_i$ there exists a saturated neighborhood U_x such that its lift \tilde{U}_x is trivially foliated as a product. By the relative compactness of V_i we can cover V_i by a finite number of such saturated neighborhoods $\{V_i^j\}_j$ such that each \tilde{V}_i^j is trivially foliated as a product by $\tilde{\mathcal{W}}^c$. Let $x \in M$ be an arbitrary point and $i \in \{1, \dots, l\}$ such that $B_H(W^c(x), \delta_0) \subset V_i$. Let $\delta^* > 0$ be given. Let $\tilde{W}^c(x) \subset \tilde{V}_i^j$ and $\tilde{W}^c(x) = \tilde{W}^c(x_i)$ where $x_i \in p_i^{-1}x$. Then there exists $\delta_j > 0$ such that $\tilde{\mathcal{W}}^c(B_{\delta_j}(x_i)) \subset B_H(\tilde{W}^c(x_i), \delta^*) \subset \tilde{V}_i^j$. If necessary, we shrink $\delta_j > 0$ such that $p_i|_{B_{\delta_j}(x)}$ is an isometry. Then for every $W^c(y) \subset V_i^j$ with $d_H(W^c(x), W^c(y)) < \delta_j$ there exists $y \in W^c(y)$ such that $d(x, y) < \delta_j$ and there exists $y_i \in p_i^{-1}y$ such that $d(x_i, y_i) < \delta_j$. Hence, $\tilde{W}^c(y_i) \subset \tilde{\mathcal{W}}^c(B_{\delta_j}(x_i)) \subset B_H(\tilde{W}^c(x_i), \delta^*)$. By taking the minimum of these δ_j and defining it as δ and repeating this procedure for all neighborhoods V_i we get the searched $\delta > 0$ which fulfills the statement of the Lemma globally. □

Lemma 1.70. *Given holonomy covers $\{U_i, q_i\}$ as in Lemma 1.66 and $\{V_i, p_i\}_{i=1}^l$ and δ_0 as in Lemma 1.67. Then there exists $\delta_0^* > 0$ such that for all $x \in M$, $i, j \in \{1, \dots, l\}$ such that $B_H(W^c(x), \delta_0) \subset V_i \cap V_j$, for all $x_1 \in p_i^{-1}(x), x_2 \in p_j^{-1}(x)$ there exists an isometry*

$$I : B_H(\tilde{W}^c(x_1), \delta_0^*) \rightarrow B_H(\tilde{W}^c(x_2), \delta_0^*)$$

such that $p_j \circ I = \text{id}_M \circ p_i$.

Proof. We fix a holonomy cover $\{V_i\}_{i=1}^l$ and δ_0 as in Lemma 1.67. We take $x \in M$ and $i, j \in \{1, \dots, l\}$ such that $B_H(W^c(x), \delta_0) \subset V_i \cap V_j$ and $B_H(W^c(x), \frac{1}{2}\delta_0)$ is away from the border of $V_i \cap V_j$. Recall that the cover $\{V_i\}$ is chosen such that each V_i is relatively compact inside some neighborhood U_j . We construct a smooth disk through $x \in M$ transverse to the foliation \mathcal{W}^c by taking a disk $D_{x, 2\delta_0^*} \subset E^s(x) \oplus E^u(x)$ of diameter $2\delta_0^*$ around $0 \in T_x M$ where we choose $\delta_0^* > 0$ sufficiently small such that the image of this disk

under the exponential map is entirely contained inside $B_H(W^c(x), \frac{1}{2}\delta_0)$. We consider now the image of $D_{x,2\delta_0^*}$ under the local diffeomorphism \exp_x which is a submanifold transverse to $\mathcal{W}^c(x)$ and inside $V_i \cap V_j$ which we call $D_{x,2\delta_0^*}$ again. The covering maps p_i and p_j are local isometries and $V_i \cap V_j$ is a relatively compact set, hence, we can cover $D_{x,2\delta_0^*}$ with a finite number of open sets which are sent isometrically onto open sets in $p_i^{-1}D_{x,2\delta_0^*}$ and $p_j^{-1}D_{x,2\delta_0^*}$ respectively. So, there are isometries I_i, I_j for the whole transversal disk $D_{x,2\delta_0^*}$. We can continue these isometries I_i, I_j to the saturate $\mathcal{W}^c(D_{x,2\delta_0^*})$ by continuing the maps I_i, I_j along every leaf. The uniform continuity of I_i, I_j by the relative compactness of $V_i \cap V_j$ and the compactness of each leaf imply that open saturated sets are mapped onto open saturated sets. The saturate $\mathcal{W}^c(D_{x,2\delta_0^*})$ is then mapped isometrically with respect to the Hausdorff metric d_H . It is $B_H(\tilde{W}^c(x), \delta_0^*) \subset p_i^{-1}\mathcal{W}^c(D_{x,2\delta_0^*})$ and hence, the Lemma is proved. \square

Corollary 1.71. *For all $x, y \in M$ it holds: If there exists $i \in \{1, \dots, l\}$ such that $B_H(W^c(x), \delta_0) \subset V_i$ and if there exist $x_i \in p_i^{-1}(x)$ and $y_i \in p_i^{-1}(y)$ such that $d_H(\tilde{W}^c(x_i), \tilde{W}^c(y_i)) < \delta_0^*$ then for all j such that $B_H(W^c(x), \delta_0) \subset V_j$, for all $x_j \in p_j^{-1}(x)$ there exists $y_j \in p_j^{-1}(y)$ such that $d_H(\tilde{W}^c(x_j), \tilde{W}^c(y_j)) = d_H(\tilde{W}^c(x_i), \tilde{W}^c(y_i)) \leq \delta_0^*$.*

Proof. This is a direct implication of Lemma 1.70. \square

We fix $\delta > 0$ with $\delta < \frac{1}{2}\delta_0$ in M corresponding to δ_0^* following Lemma 1.69. We define for every pair $W^c(x), W^c(y)$ of center leaves the following distance:

$$\Delta_H(W^c(x), W^c(y)) := \begin{cases} \frac{1}{2}\delta_0^*, & \text{if } d_H(W^c(x), W^c(y)) \geq \delta \\ \min \left\{ \frac{1}{2}\delta_0^*, \inf \left\{ d_H(\tilde{W}^c(x_i), \tilde{W}^c(y_i)) \mid x_i \in p_i^{-1}(x) \right\} \right\} \end{cases}.$$

We denote with a ball with respect to this new distance by

$$B_{\Delta_H}(W^c(x), \delta) := \{W^c(y) \subset M \mid \Delta_H(W^c(x), W^c(y)) < \delta\}.$$

Lemma 1.69 implies that:

Corollary 1.72. Δ_H is a distance and it is topologically equivalent to d_H , i.e. for $x \in M$ and all $\delta^* > 0$ there exist $\delta_{\min}, \delta_{\max} > 0$ with $\delta_{\min}, \delta_{\max} < \frac{1}{2}\delta_0$ such that

$$B_H(W^c(x), \delta_{\min}) \subset B_{\Delta_H}(W^c(x), \delta^*) \subset B_H(W^c(x), \delta_{\max}). \quad (1.12)$$

1.3. Dynamics on the leaf space

Proof. The positive definiteness and symmetry are directly inherited by d_H . For the triangle inequality we have to consider different cases:

Case I: Let $W^c(x), W^c(y) \subset M$ be two center leaves with $d_H(W^c(x), W^c(y)) \geq \delta$. Then it is $\Delta_H(W^c(x), W^c(y)) = \frac{1}{2}\delta_0^*$. If for any $W^c(z)$ one of the pairs $W^c(x), W^c(z)$ or $W^c(y), W^c(z)$ has a Hausdorff distance $d_H \geq \delta$, the triangle inequality is fulfilled. If $d_H(W^c(z), W^c(x)) < \delta$ and $d_H(W^c(z), W^c(y)) < \delta$, then there exists a lifted center leaf $\tilde{W}^c(z)$ such that the minimum of $d_H(\tilde{W}^c(z), \tilde{W}^c(x))$ is attained and less than $\frac{1}{2}\delta_0^*$ (otherwise the inequality is implied), and the same holds for $W^c(z), W^c(x)$. Hence, there exists lifted center leaves of $W^c(x)$ and $W^c(y)$ which lie in the same δ_0^* -neighborhood of a lift of $W^c(z)$ contradicting the assumption of Case I.

Case II: Let $W^c(x), W^c(y) \subset M$ be two center leaves with $d_H(W^c(x), W^c(y)) < \delta$. Hence, there exist lifted center leaves $\tilde{W}^c(x), \tilde{W}^c(y)$ which attain the minimum of the Hausdorff distances between lifted center leaves. Let $W^c(z)$ be any other center leaf with a Hausdorff distance $d_H < \delta$ with respect to $W^c(x)$ and $W^c(y)$, otherwise the triangle inequality is trivially implied. We choose lifted center leaves $\tilde{W}_1^c(z)$ and $\tilde{W}_2^c(z)$ such that $\Delta_H(W^c(x), W^c(z)) = d_H(\tilde{W}^c(x), \tilde{W}_1^c(z))$ and $\Delta_H(W^c(y), W^c(z)) = d_H(\tilde{W}^c(y), \tilde{W}_2^c(z))$. With Corollary 1.71 we can conclude that if $d_H(\tilde{W}^c(y), \tilde{W}_2^c(z)) \leq \frac{1}{2}\delta_0^*$ is minimal then for any other lifted center leaf of $W^c(z)$, especially for $\tilde{W}_1^c(z)$ there exists another lifted center leaf $\tilde{W}_1^c(y)$ of $W^c(y)$ such that

$$d_H(\tilde{W}^c(y), \tilde{W}_2^c(z)) = d_H(\tilde{W}_1^c(y), \tilde{W}_1^c(z)) \leq \frac{1}{2}\delta_0^*.$$

Then it is $d_H(\tilde{W}^c(x), \tilde{W}_1^c(y)) \leq \delta_0^*$. Hence, we obtain the following

$$\begin{aligned} \Delta_H(W^c(x), W^c(y)) &= d_H(\tilde{W}^c(x), \tilde{W}^c(y)) \\ &\leq d_H(\tilde{W}^c(x), \tilde{W}_1^c(y)) \\ &\leq d_H(\tilde{W}^c(x), \tilde{W}_1^c(z)) + d_H(\tilde{W}_1^c(z), \tilde{W}_1^c(y)) \\ &= \Delta_H(W^c(x), W^c(z)) + \Delta_H(W^c(z), W^c(y)) \end{aligned}$$

Topological equivalence: We now show that Δ_H is a topologically equivalent distance to d_H . Let $x \in M$ and δ^* be given. If $\delta^* \geq \frac{1}{2}\delta_0^*$, then $B_{\Delta_H}(W^c(x), \delta^*) = M$ and the inclusion (1.12) is easily fulfilled for $\delta_{\max} > 0$ chosen greater than the diameter of M/\mathcal{W}^c and $\delta_{\min} > 0$ any smaller number.

If $\delta^* < \frac{1}{2}\delta_0^*$, then with Lemma 1.69 there exists $\delta_{\min}(\delta^*) > 0$ such that $B_H(W^c(x), \delta_{\min}) \subset B_{\Delta_H}(W^c(x), \delta^*)$. As $\delta^* < \frac{1}{2}\delta_0^*$ and δ_0^* was chosen sufficiently small in Lemma 1.70 we can choose $\delta_{\max} = \delta_0$ such that the \mathcal{W}^c -

saturated set $B_{\Delta_H}(W^c(x), \delta^*) \subset B_H(W^c(x), \delta_0)$. This shows the topological equivalence between both distances. \square

Proving the properties (B1)-(B5). The properties are proved for the cover $\{V_i\}$ and $\frac{1}{2}\delta_0^* > 0$ as defined above. We choose an appropriate $\eta > 0$ as in the proof for trivial holonomy and define equally for lifted center leaves $\tilde{W}^c(\tilde{W}_\eta^s(x)) = \tilde{W}_{loc}^{cs}(x)$ and $\tilde{W}^c(\tilde{W}_\eta^u(x)) = \tilde{W}_{loc}^{cu}(x)$.

We start with establishing property (B1). We defined in the preceding paragraph the metric Δ_H between center leaves and showed in Corollary 1.72 that Δ_H is actually a metric and topologically equivalent to d_H . We fix $\delta > 0$ corresponding to $\frac{1}{2}\delta_0^*$. Let $W^c(x), W^c(y) \in M$ be any pair of center leaves and assume in the following that $W^c(x), W^c(y)$ fulfill the assumptions of Lemma 1.70, i.e. $d_H(W^c(x), W^c(y)) < \delta$. Then there exist lifted center leaves $\tilde{W}^c(x), \tilde{W}^c(y)$ in the holonomy cover such that the minimum of the Hausdorff distances is attained, i.e.

$$\Delta_H(W^c(x), W^c(y)) = d_H(\tilde{W}^c(x), \tilde{W}^c(y)) \leq \frac{1}{2}\delta_0^*.$$

Hence, these lifted center leaves intersect in a center leaf

$\tilde{W}^c(z_{x,y}) \subset \tilde{W}_{loc}^{cu}(x) \cap \tilde{W}_{loc}^{cs}(y)$ in the holonomy cover such that the following inequalities hold

$$d_H(\tilde{W}^c(x), \tilde{W}^c(z_{x,y})) < Cd_H(\tilde{W}^c(x), \tilde{W}^c(y)), \text{ and} \quad (1.13)$$

$$d_H(\tilde{W}^c(y), \tilde{W}^c(z_{x,y})) < Cd_H(\tilde{W}^c(x), \tilde{W}^c(y)). \quad (1.14)$$

The choice of the lifted center leaves $\tilde{W}^c(x), \tilde{W}^c(y)$ might not be unique nor is the choice of the intersection leaf $\tilde{W}^c(z_{x,y})$. But we know by the trivial holonomy of the lifted center leaves and the product structure that an intersection leaf $\tilde{W}^c(z_{x,y})$ exists which fulfills the inequalities above. This implies property (B1). In the following, we choose three lifted center leaves with the properties above and we fix them to define the stable and unstable distances.

For property (B2) we choose for any pair $W^c(x), W^c(y) \subset M$ with $d_H(W^c(x), W^c(y)) < \delta$ a pair of lifted center leaves $\tilde{W}^c(x), \tilde{W}^c(y)$ with $d_H(\tilde{W}^c(x), \tilde{W}^c(y)) = \Delta_H(W^c(x), W^c(y))$ and an intersection leaf $\tilde{W}^c(z_{x,y})$ which fulfills the inequalities (1.13) and (1.14). Then we define

$$\Delta_s(W^c(x), W^c(y)) := \Delta_s(\tilde{W}^c(y), \tilde{W}^c(z_{x,y})),$$

$$\Delta_u(W^c(x), W^c(y)) := \Delta_u(\tilde{W}^c(x), \tilde{W}^c(z_{x,y})).$$

The inequalities in (B2) are then directly implied by the properties (B2) of Δ_s and Δ_u for center leaves with trivial holonomies.

1.3. Dynamics on the leaf space

The subsequent properties (B3)-(B5) are direct consequences of the definition of Δ_s and Δ_u and the corresponding properties (B3)-(B5) in the case of a center foliation with trivial holonomy.

Adapting Bowen's proof of the Shadowing Lemma. We choose N sufficiently big such that $2C^2\lambda^N < 1$. We denote λ^N with Λ and f^N with g . Let $\epsilon > 0$ be given. First, there exists $\epsilon^* > 0$ such that for every $x \in M$ it is $B_{\Delta_H}(W^c(x), \epsilon^*) \subset B_H(W^c(x), \epsilon)$. Then we choose $\delta^* < \frac{1}{4}\delta_0^*$ such that $\frac{2C^2\delta^*}{1-\Lambda} < \epsilon^*$. Then there exists $\delta > 0$ such that for all $x \in M$ it is $B_H(W^c(x), \delta) \subset B_{\Delta_H}(W^c(x), \delta^*)$. Let $\{W^c(x_i)\}_{i \in \mathbb{Z}}$ be a δ -pseudo-orbit with respect to d_H and g .

We construct a sequence $\{W^c(z_j)\}_{j \geq 0}$ of center leaves such that the accumulation point is the searched orbit which ϵ -shadows the pseudo-orbit. First, we define $W^c(z_0)$ in the following way. It is $d_H(W^c(x_1), W^c(g(x_0))) < \delta$, therefore there exist lifted center leaves $\tilde{W}^c(x_1), \tilde{W}^c(g(x_0))$ such that

$$d_H(\tilde{W}^c(x_1), \tilde{W}^c(g(x_0))) = \Delta_H(W^c(x_1), W^c(g(x_0))) < \delta^*.$$

Hence, there exist

$$\tilde{W}^c(z_0) \subset \tilde{W}_{loc}^{cs}(x_1) \cap \tilde{W}_{loc}^{cu}(g(x_0))$$

such that $\tilde{W}^c(z_0)$ fulfills the inequalities (1.13) and (1.14).

Claim: We claim, that for every $j \geq 0$ there exists a lifted center leaf $\tilde{W}^c(z_j)$ such that

(I1) there exist lifted center leaves $\tilde{W}^c(g^{j+2}(z_j)), \tilde{W}^c(x_{j+2})$ such that $d_H(\tilde{W}^c(g^{j+2}(z_j)), \tilde{W}^c(x_{j+2})) < 2\delta^*$, and

(I2) there exist lifted center leaves $\tilde{W}^c(g^k(z_j)), \tilde{W}^c(x_k)$ such that

$$\tilde{W}^c(g^k(z_j)), \tilde{W}^c(x_k) < 2C^2\delta^* \sum_{i=0}^{j-k} \Lambda^i < \epsilon^*, \text{ for } 0 \leq k \leq j.$$

If we take the accumulation point of the sequence of $\{W^c(z_j)\}$ in M we can conclude with (I2) that

$$\Delta_H(W^c(g^k(z)), W^c(x_k)) < \epsilon^* \text{ for } k \geq 0.$$

This implies $d_H(W^c(g^k(z)), W^c(x_k)) < \epsilon$ for $k \geq 0$ and this proves the Lemma. So let us prove the claim by induction. Let $\tilde{W}^c(z_j)$ be constructed

fulfilling (I1) and (I2). By (I1) we get that there exist lifted leaves $\tilde{W}^c(g^{j+2}(z_j))$ and $\tilde{W}^c(x_{j+2})$ at a distance $< 2\delta^*$, by the choice of δ^* we find $\tilde{W}^c(g^{j+2}(z_{j+1}))$ in the intersection $\tilde{W}_{loc}^{cu}(g^{j+2}(z_j))$ with $\tilde{W}_{loc}^{cs}(x_j)$ such that inequalities (1.13) and (1.14) are fulfilled. We can establish then items (I1) and (I2) in exactly the same way as in the proof for trivial holonomy.

1.4 Orientability and covering spaces

As we assume a one-dimensional stable and/ or unstable bundle the question of orientability of the stable and/or unstable bundle is essential for the understanding of the holonomy homeomorphisms along center leaves. A foliation is called *transversely orientable* if the determinant of the Jacobian of any holonomy map $c_{\alpha\beta}$ is positive. In our case, where every holonomy map $c_{\alpha\beta}$ is only continuous, we say that a foliation \mathcal{F} is transversely non-orientable if the direct product $T \times [0, 1]$ of a smooth manifold T embedded transverse to \mathcal{F} is contained in M by gluing together at one end $T \times \{0\}$ and $T \times \{1\}$ at the other end with a single reflection. This is equivalent to the existence of a orientation-reversing holonomy homeomorphism. In the case of a transversely non-orientable codimension-one foliation this means that the Moebius strip is contained in M in such a way that it intersects the foliation in circles. Every leaf of a codimension-one foliation has a subgroup of $\text{Homeo}((-1, 1))$ the group of germs of homeomorphism on $(-1, 1)$ as holonomy group. Consequently, it has either one or two elements, depending if the normal bundle is oriented or not. In the special case of a codimension-one foliation it is therefore crucial to lift the foliation to the cover of orientation of the normal bundle where the holonomy of the lifted foliation is eliminated. We use this technique a lot during the proof of our main theorems and therefore we state here some facts about orientation covers:

If a connected n -manifold M is not orientable, it has a canonical connected 2-fold orientation cover $p : \tilde{M} \rightarrow M$ such that \tilde{M} is orientable. If there is a foliation \mathcal{F} on M , the covering map p lifts \mathcal{F} to a well defined foliation $\tilde{\mathcal{F}} = p^*\mathcal{F}$. There is a corresponding construction such that $p^*\mathcal{F}$ is transversely orientable. This is the content of the following Theorem (proved in [CC00]):

Theorem 1.73. *Let (M, \mathcal{F}) be a foliated manifold, M connected. If M is nonorientable and/ or \mathcal{F} is not transversely orientable, then there is a connected covering space (either 2-fold or 4-fold) $p : \tilde{M} \rightarrow M$ such that \tilde{M} is orientable and the lifted foliation $\tilde{\mathcal{F}}$ is unique and transversely orientable. In this case, the leaves of $\tilde{\mathcal{F}}$ are all orientable.*

1.4. Orientability and covering spaces

If E^s and E^u are non-oriented we define $p : \tilde{M} \rightarrow M$ as the orientation cover of both E^s and E^u by

$$\tilde{M} := \{(x, s_x, u_x) \mid s_x \text{ orientation of } E^s(x), u_x \text{ orientation of } E^u(x)\}.$$

It is 4-folded and connected. The center-stable and center-unstable foliations are lifted to transversely orientable foliations $p^*\mathcal{W}^{cs} = \tilde{\mathcal{W}}^{cs}$ and $p^*\mathcal{W}^{cu} = \tilde{\mathcal{W}}^{cu}$. A homeomorphism $c : \tilde{M} \rightarrow \tilde{M}$ is called *covering transformation* if $p \circ c = p$. Every covering transformation permutes therefore the elements of each fiber. They form a group, $\text{Aut}(p)$, which acts on every fiber. As every fiber $p^{-1}(x)$ consists of four points the covering transformation can be either trivial or exchanging the orientations of $E^s(x)$ and/or $E^u(x)$. The automorphism group $\text{Aut}(p)$ is therefore isomorphic to $\mathbb{Z}_2 \times \mathbb{Z}_2$, the Klein four-group, as any non-trivial element has order 2.

Every cover has the *path lifting property*:

Theorem 1.74 (Path-lifting property). *If $p : \tilde{M} \rightarrow M$ is a cover and if $\gamma : [0, 1] \rightarrow M$ is a path in M with $\gamma(0) = x$ and $\tilde{x} \in p^{-1}(x)$ then there exists a unique path $\tilde{\gamma}$ in \tilde{M} such that $p \circ \tilde{\gamma} = \gamma$ and $\tilde{\gamma}(0) = \tilde{x}$.*

Consider a closed path γ with $\gamma(0) = \gamma(1) = x$ such that it is orientation-reversing of E^s and orientation-preserving of E^u . If we lift γ to the unique path $\tilde{\gamma}_1$ in the orientation cover \tilde{M} with $\tilde{\gamma}_1(0) = \tilde{x} \in p^{-1}x$ then $\tilde{\gamma}_1(1) \neq \tilde{\gamma}_1(0)$. So we can lift γ to the unique path $\tilde{\gamma}_2$ with $\tilde{\gamma}_2(0) = \tilde{\gamma}_1(1)$ and return to $\tilde{x} = \tilde{\gamma}_2(1)$ again. So the closed path $\tilde{\gamma} = \tilde{\gamma}_2 \circ \tilde{\gamma}_1$ with $\tilde{\gamma}(0) = \tilde{\gamma}(1) = \tilde{x}$ projects onto 2γ . The pre-image $p^{-1}\gamma$ has two connected components and both projects onto 2γ . The same holds if we exchange E^s and E^u . Now suppose that E^s and E^u are not oriented along the path γ . Then we need again two turns of γ to obtain a closed path $\tilde{\gamma}$ in the orientation cover. The pre-image $p^{-1}\gamma$ has again two connected components and both projects onto 2γ .

If we suppose that both E^s and E^u are oriented along the path γ then the lifted path $\tilde{\gamma}$ is closed and the pre-image $p^{-1}\gamma$ has four connected components.

A cover is called *regular* if the automorphism group $\text{Aut}(p)$ acts transitively on each fiber. The orientation cover above is always regular and $p : \tilde{M} \rightarrow M$ is a principal $\text{Aut}(p)$ -bundle where $\text{Aut}(p)$ is considered as a discrete topological group. The manifold M is homeomorphic to $\tilde{M}/\text{Aut}(p)$.

An application of the path lifting property is the following classical proposition which will be used in the context of the Reeb Stability Theorem 1.6:

Proposition 1.75. *The map $p_{\#} : \pi_1(\tilde{M}, \tilde{x}) \rightarrow \pi_1(M, x)$ induced by a covering space $p : \tilde{M} \rightarrow M$ with $p(\tilde{x}) = x$ is injective. The image subgroup*

$p_{\#}(\pi_1(\tilde{M}, \tilde{x})) < \pi_1(M, x)$ consists of homotopy classes of loops in M based at x whose lifts to \tilde{M} at \tilde{x} are loops.

The cardinality of every fiber $p^{-1}x$, called number of sheets, equals $\frac{|\pi_1(M, x)|}{|p_{\#}(\pi_1(\tilde{M}, \tilde{x}))|}$.

If the cover is regular we know that the group of covering transformations $\text{Aut}(p)$ is isomorphic to $\pi_1(M, x) / p_{\#}(\pi_1(\tilde{M}, \tilde{x}))$; especially, in the case of a universal cover it holds that the group $\text{Aut}(p)$ is isomorphic to the fundamental group $\pi_1(M, x)$. This will be useful for calculating the order of holonomy groups.

If E^s is non-orientable we define $p : \tilde{M}^s \rightarrow M$ as the orientation cover of E^s by

$$\tilde{M}^s := \{(x, s_x) \mid s_x \text{ orientation of } E^s(x)\}.$$

It is a 2-fold cover and connected. The automorphism group $\text{Aut}(p)$ is isomorphic to \mathbb{Z}_2 and is generated by the identity and a covering transformation with exchanges the orientation of $E^s(x)$. We define \tilde{M}^u in an analogous way to be the orientation cover of E^u .

We can lift the partially hyperbolic diffeomorphism $f : M \rightarrow M$ to a diffeomorphism $\tilde{f} : \tilde{M} \rightarrow \tilde{M}$ by $\tilde{f}(x, s_x, u_x) := (f(x), s_{f(x)}, u_{f(x)})$ as the stable and unstable bundle are df -invariant and \tilde{f} is equivariant under the action of the orientation-reversing automorphisms in $\text{Aut}(p)$, i.e. $\tilde{f}(cx) = c\tilde{f}(x)$ for any $c \in \text{Aut}(p)$. So, the map \tilde{f} is clearly partially hyperbolic.

2

Compact center foliations with finite holonomy under restrictions on the codimension

2.1 Main theorems

We summarize the main theorems of this thesis which we prove step by step in the subsequent sections. We start with the easiest result in the case of a compact center foliation of codimension two.

Theorem A. *Let $f : M \rightarrow M$ be a partially hyperbolic C^1 -diffeomorphism on a compact smooth connected manifold M . Assume that the center foliation \mathcal{W}^c is an invariant compact foliation and $\text{codim } \mathcal{W}^c = 2$. Then the following statements hold:*

1. *The center leaves with non-trivial holonomy are isolated and its number is either four or zero. They lie on periodic orbits. Every non-trivial holonomy homeomorphism is a rotation by π .*
2. *The leaf space M/\mathcal{W}^c is either a 2-orbifold with four elliptic points and underlying manifold a 2-sphere or it is a 2-torus.*
3. *The system can be lifted to a partially hyperbolic system $\tilde{f} : \tilde{M}^u \rightarrow \tilde{M}^u$ on the 2-fold cover \tilde{M}^u of orientation of E^u such that $\pi : \tilde{M}^u \rightarrow \tilde{M}^u/\tilde{\mathcal{W}}^c$ is a fiber bundle, the leaf space $\tilde{M}^u/\tilde{\mathcal{W}}^c$ is \mathbb{T}^2 and \tilde{f} projects to $F : \mathbb{T}^2 \rightarrow \mathbb{T}^2$ which is conjugate to a linear Anosov map.*

Remark 2.1. *The result above that there exists a finite cover of M such that the holonomy of the lifted center foliation is trivial is not as obvious*

as it may seem at the first glance. There exist 2-dimensional orbifolds, so-called bad orbifolds, which are not finitely covered by a manifold. Hence, the existence of such a cover in our case is due to the facts that the orbifold structure on the leaf space has its offspring in a compact foliation with finite holonomy and that there exists a partially hyperbolic diffeomorphism on the manifold M .

In the case of a codimension-3 center foliation we get the following respective result:

Theorem B. *Let $f : M \rightarrow M$ be a partially hyperbolic C^1 -diffeomorphism with a f -invariant compact center foliation with finite holonomy. Assume $\dim E^s = 2$ and $\dim E^u = 1$. Then the following statements hold:*

1. *Every non-trivial holonomy homeomorphism is $-\text{id}$, and the center leaves with non-trivial holonomy are isolated and lie on periodic orbits.*
2. *The leaf space M/W^c is either a 3-orbifold $\mathbb{T}^3/(-\text{id})$ with 8 singular points or a 3-torus.*
3. *The system can be lifted to a partially hyperbolic system $\tilde{f} : \tilde{M}^u \rightarrow \tilde{M}^u$ on the 2-fold cover \tilde{M}^u of orientation of E^u such that $\pi : \tilde{M}^u \rightarrow \tilde{M}^u/\tilde{W}^c$ is a fiber bundle, the leaf space \tilde{M}^u/\tilde{W}^c is \mathbb{T}^3 and \tilde{f} projects to $F : \mathbb{T}^3 \rightarrow \mathbb{T}^3$ conjugate to a linear Anosov map.*

In higher codimensions under the assumption of a one-dimensional unstable bundle we obtain a similar result. We recall that a partially hyperbolic diffeomorphism f is called *centrally transitive* if there exists a dense forward orbit of center leaves, i.e. there exists $x \in M$ such that $\overline{\bigcup_{n \in \mathbb{N}} f^n W^c(x)} = M$. Clearly, any transitive f is centrally transitive.

Theorem C. *Let $f : M \rightarrow M$ be a partially hyperbolic C^1 -diffeomorphism on a compact smooth connected manifold M . Assume that the center foliation W^c is a f -invariant compact foliation with finite holonomy and $\dim E^u = 1$. Then the following statements hold:*

1. *The diffeomorphism f is centrally transitive.*
2. *Center leaves with non-trivial holonomy are isolated. Every non-trivial holonomy homeomorphism is conjugate to $-\text{id}$. Lifted to the orientation cover of E^u the lifted center leaves have only trivial holonomy.*

2.1. Main theorems

3. *The system can be lifted to a partially hyperbolic system $\tilde{f} : \tilde{M}^u \rightarrow \tilde{M}^u$ on the 2-fold cover \tilde{M}^u of orientation of E^u such that $\pi : \tilde{M}^u \rightarrow \tilde{M}^u/\tilde{\mathcal{W}}^c$ is a fiber bundle, the leaf space $\tilde{M}^u/\tilde{\mathcal{W}}^c$ is \mathbb{T}^q , where $q = \text{codim } \mathcal{W}^c$ and \tilde{f} projects to $F : \mathbb{T}^q \rightarrow \mathbb{T}^q$ conjugate to a linear Anosov map.*

Remark 2.2. *As a consequence, any partially hyperbolic C^1 -diffeomorphism $f : M \rightarrow M$ with a compact f -invariant center foliation with trivial holonomy and a one-dimensional unstable bundle looks locally like a skew product of a linear Anosov map and the action of f in the center direction: As $\pi : M \rightarrow M/\mathcal{W}^c$ is a fiber bundle there exists a local trivialization. Let $U \subset M/\mathcal{W}^c$ be a trivializing neighborhood of $x \in M/\mathcal{W}^c$ sufficiently small such that there is another trivializing neighborhood V of $f(x)$ with $f(\pi^{-1}U) \subset \pi^{-1}V$ and F_x denotes the fiber of x , homeomorphic to $W^c(x)$, then it is*

$$\phi_V \circ f|_{\pi^{-1}U} = (A, \psi(x)) \circ \phi_U$$

where $\phi_U : \pi^{-1}U \rightarrow U \times F_x$ is a homeomorphism, the map A is a linear Anosov map on the $\text{codim } \mathcal{W}^c$ -torus and $\psi : U \rightarrow \text{Homeo}(F_x, F_{Ax})$ a continuous map with $\psi(x)(y) = f|_{W^c(x)}(y)$. The diffeomorphism f might not be a global skew product.

We prove every theorem in a separate section because the techniques involved are quite different. The first theorem has a quite straightforward proof while the second and third include techniques special to codimension three and a one-dimensional unstable direction respectively.

In the case of a higher-dimensional unstable bundle, e.g. $\dim E^u = 2$, the center holonomy might not be eliminated in the orientation cover of E^u and there may exist submanifolds of center leaves with non-trivial holonomy. Nevertheless, we can lift the whole system to a finite cover and obtain a partially hyperbolic system with a center foliation with trivial holonomy.

Theorem D. *Let $f : M \rightarrow M$ be a partially hyperbolic C^1 -diffeomorphism on a compact smooth connected manifold M . Assume that the center foliation \mathcal{W}^c is a f -invariant compact foliation with finite holonomy and $\dim E^s = \dim E^u = 2$. Then the following statements hold:*

1. *In the 2-fold cover \tilde{M} of orientation of E^s (or E^u) the center leaves of the lifted foliation $\tilde{\mathcal{W}}^c$ with non-trivial holonomy are isolated and hence, there are only finitely many.*
2. *Assume that the center holonomy is trivial in the orientation cover of E^s and E^u . If F is centrally transitive and if E^s and E^u are not oriented, then there exist \mathcal{W}^c -saturated two-dimensional tori $\mathcal{W}^c(T_1), \dots, \mathcal{W}^c(T_n)$*

foliated by a one-dimensional stable and one-dimensional unstable foliation which are interchanged by f . Lifted to the 4-fold cover \tilde{M} of orientation of E^s and E^u and pushed to the leaf space $\tilde{M}/\tilde{\mathcal{W}}^c$ there are two-dimensional tori $\tilde{T}_1, \dots, \tilde{T}_n$, interchanged by F and $F|_{\tilde{T}_i}$ is conjugate to a linear Anosov map.

2.2 General lemmata

First, we prove some results in the case of a one-dimensional unstable bundle E^u which we use in every proof. Since the partially hyperbolic diffeomorphism $f : M \rightarrow M$ is dynamically coherent as shown in Theorem 1.24, every center leaf $W^c(x)$ is a connected component of $W^{cs}(x) \cap W^{cu}(x)$. Let $\phi : D^q \rightarrow M$ be a smooth embedding of a q -dimensional disk D^q where $q = \text{codim } \mathcal{W}^c$, $\phi(0) = x$ and $\phi(D^q) =: T$ is transverse at x to $W^c(x)$. Then \mathcal{W}^{cs} and \mathcal{W}^{cu} induce foliations on T , called \mathcal{T}^s and \mathcal{T}^u respectively. Let $H : U \rightarrow V$ be a holonomy homeomorphism of $W^c(x)$ with $U, V \subset T$ open neighborhoods of x . It is $H(x) = x$. We denote with H_γ a holonomy homeomorphism generated by $\gamma \in \pi_1(W^c(x), x)$, with H_γ^u a holonomy homeomorphism of the center-stable foliation generated by $\gamma \in \pi_1(W^c(x), x)$ and with H_γ^s a holonomy homeomorphism of the center-unstable foliation.

The unstable bundle E^u is one-dimensional.

Lemma 2.3. *Let $f : M \rightarrow M$ be a C^1 -partially hyperbolic system with a f -invariant compact center foliation \mathcal{W}^c with finite holonomy. Assume $\dim E^u = 1$. For all $\gamma \in \pi_1(W^c(x), x)$, the holonomy map $H_\gamma : T \rightarrow T$ is a cartesian product $H_\gamma^u \times H_\gamma^s$. If E^u is oriented, then it holds $H_\gamma^u \equiv \text{id}$.*

Proof. Let $\gamma \in \pi_1(W^c(x), x)$ be an arbitrary closed path. The path γ is tangent to a leaf of \mathcal{W}^{cs} and to a leaf of \mathcal{W}^{cu} as the center foliation \mathcal{W}^c is subordinate to both foliations. As transversal for H_γ^u we can choose T_x^u , for H_γ^s in an analogous way T_x^s . As f is dynamically coherent and \mathcal{T}^u and \mathcal{T}^s are induced transversal foliations on T , the holonomy $H_\gamma|_{T_x^u}$ coincides with H_γ^u , in an analogous way the holonomy map $H_\gamma|_{T_x^s}$ coincides with H_γ^s . Locally, the transversal foliations \mathcal{T}^s and \mathcal{T}^u induce a product structure on T . So T is homeomorphic to an open set $U \subset \mathbb{R}^q$ with $q = \dim E^s + \dim E^u$ such that the stable and unstable plaques in T are mapped to the canonical coordinates in U . Therefore H_γ is the cartesian product of $H_\gamma^u \times H_\gamma^s$ and preserves the foliations \mathcal{T}^u and \mathcal{T}^s . If E^u is oriented, then \mathcal{W}^{cs} is a transversely orientable codimension-1 foliation and every holonomy homeomorphism $H_\gamma^u : T_x^u \rightarrow T_x^u$ is conjugate to the identity due to Lemma 1.13. \square

2.2. General lemmata

In the following proofs we consider sets of center leaves with a maximal holonomy group, and it is crucial for the proofs to know that such sets are f -invariant. Hence, we need the following:

Lemma 2.4. *Let $\text{Hol}(W^c(x), x)$ be a finite holonomy group of a compact leaf $W^c(x)$. Let $H_\gamma \in \text{Hol}(W^c(x), x)$ be a periodic holonomy homeomorphism. Then the period of $H_\gamma : T \rightarrow T$ is constant along an orbit of f , i.e. the period of $H_{f \circ \gamma}$ is equal to the period of H_γ . Every holonomy group $\text{Hol}(W^c(f^k(x)), f^k(x))$ for $k \in \mathbb{Z}$ is isomorphic to the holonomy group $\text{Hol}(W^c(x), x)$ of $W^c(x)$.*

Proof. Let $H_\gamma \in \text{Hol}(W^c(x), x)$ be a periodic holonomy homeomorphism. Let $k \in \mathbb{N}$ be the period of H_γ . The path $f \circ \gamma$ generates a holonomy homeomorphism of $W^c(f(x))$. Because of the invariance of the foliations we conclude that $H_{f \circ \gamma} = f \circ H_\gamma \circ f^{-1} : f(T) \rightarrow f(T)$. Hence, the period of $H_{f \circ \gamma}$ is equally k . This induces a bijection between the holonomy homeomorphisms $H_\gamma \in \text{Hol}(W^c(x), x)$ and $H_{f \circ \gamma} \in \text{Hol}(W^c(f(x)), f(x))$. Accordingly, the order of the whole holonomy group is constant along a f -orbit. \square

Hence, we can say that f is equivariant under Hol , i.e. $f(H(y)) = H(f(y))$ for any $H \in \text{Hol}$ and $y \in T$.

We define the following set A of all points $x \in M$ whose center leaves have a holonomy group $\text{Hol}(W^c(x))$ of maximal order.

Lemma 2.5. *Let $f : M \rightarrow M$ be a partially hyperbolic C^1 -diffeomorphism with a compact f -invariant center foliation with finite holonomy. Then the following hold:*

1. *There exists a point $x \in M$ such that the order*

$$|\text{Hol}(W^c(x), x)| = \max_{y \in M} |\text{Hol}(W^c(y), y)|$$

is maximal.

2. *Assume $\dim E^u = 1$ and E^u is oriented. Then the set*

$$A := \{y \in M \mid |\text{Hol}(W^c(y))| = |\text{Hol}(W^c(x))|\}$$

is closed, f -invariant and for any $y \in A$ it holds $T_y^u \subset A$.

Proof. Due to the Reeb Stability Theorem 1.6 the map $x \in M \mapsto |\text{Hol}(W^c(x), x)|$ is locally upper semi-continuous and as M is compact there is always a point $x \in M$ with a holonomy group of maximal order. So we can show the

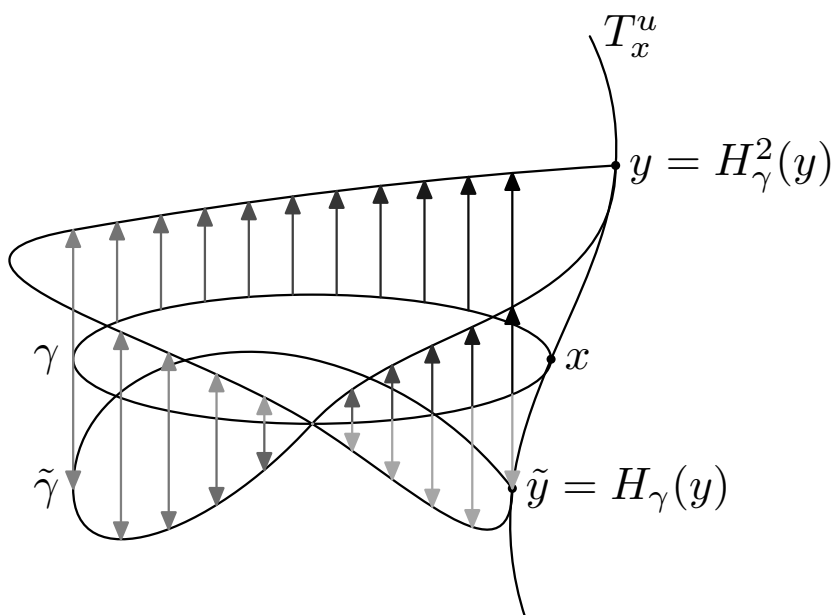

Figure 2.1: The holonomy map $H : T \rightarrow T$ reverses the orientation of E^u along γ . The path $\tilde{\gamma}$ denotes the lift of γ from $W^c(x)$ to $W^c(y)$.

second item: First of all, the set A is f -invariant because the holonomy is constant along orbits of f as we showed in Lemma 2.4 above. Due to the Reeb Stability Theorem 1.6 the map $x \in M \mapsto |\text{Hol}(W^c(x))|$ is locally upper semi-continuous so A defined by the maximum is a closed set.

Since \mathcal{W}^{cs} is a transversely orientable codimension-1 foliation every holonomy homeomorphism maps T_x^u trivially onto itself. The map H_γ^u coincides with $H_\gamma|_{T_x^u}$ and therefore the holonomy group $\text{Hol}(W^c(y))$ restricted to T_x^u for every $y \in T_x^u$ is trivial. Choose the transversal T at x to $W^c(x)$ such that $T \subset V$ where V is the neighborhood of Theorem 1.6. Then for every $y \in T_x^u$ it is $|\text{Hol}(W^c(y))| \leq |\text{Hol}(W^c(x))|$ and $p : W^c(y) \rightarrow W^c(x)$ is a covering space. For every $y \in V$ the holonomy group $\text{Hol}(W^c(y), y)$ equals the isotropy subgroup of $\text{Hol}(W^c(x), x)$ for y . As every point $y \in T_x^u$ is fixed by the entire group $\text{Hol}(W^c(x), x)$, both holonomy groups coincide and $|\text{Hol}(W^c(y), y)| = |\text{Hol}(W^c(x), x)|$ is implied. \square

As an implication we obtain that the set A of center leaves with a holonomy group of maximal order is \mathcal{W}^{cu} -saturated if the unstable bundle is one-dimensional and oriented.

Corollary 2.6. *Under the assumptions of Lemma 2.5 and further, that*

$\dim E^u = 1$ and E^u is oriented, the set A as defined above is \mathcal{W}^{cu} -saturated.

Proof. As M is a compact manifold and every center leaf is compact with finite holonomy we can find a finite cover of M (and especially of $W^{cu}(x)$) by normal neighborhoods $p_i : V_i \rightarrow W^c(x)$ as in Lemma 2.5 above. In every neighborhood V_i it holds that $W_{loc}^{cu}(x) \subset A$ for every $x \in A$ and it follows $W^{cu}(x) \subset A$. \square

2.2.1 Transitivity on the leaf space

The most important theorem in this section is the following proof of central transitivity of f under the assumption of a one-dimensional unstable direction. It relies on the simplified proof by Hiraide in [Hir01] of Newhouse's theorem ([New70]) that every codimension-one Anosov diffeomorphism is transitive. The idea of Hiraide's proof can be used, but we encounter a lot of difficulties as points in our case are substituted by compact center manifolds. The main ingredient to accomplish the proof nevertheless is the Shadowing Lemma 1.65 which we proved in the setting of a compact center foliation with finite holonomy.

The following Theorem is identical to Theorem C(1).

Theorem 2.7 (Theorem C(1)). *Let $f : M \rightarrow M$ be a partially hyperbolic C^1 -diffeomorphism with a compact f -invariant center foliation with finite holonomy. Suppose that $\dim E^u = 1$. Then f is centrally transitive.*

Remark 2.8. *First, we observe that Theorem 2.7 proved under the additional assumption of an orientable unstable bundle E^u implies Theorem 2.7. If the unstable bundle is non-orientable, the whole system f can be lifted to a partially hyperbolic system \tilde{f} on the 2-cover \tilde{M} of orientation of E^u and \tilde{f} fulfills all the assumptions of Theorem 2.7 plus orientability of E^u , hence, the diffeomorphism \tilde{f} is centrally transitive and consequently, f is centrally transitive.*

In the following we assume that E^u is oriented. As a consequence, the center-stable foliation \mathcal{W}^{cs} is without holonomy. The proof of the theorem divides into the following two steps:

Proposition 2.9. *Under the assumptions of Theorem 2.7, the diffeomorphism f is centrally chain transitive, i.e. $F : M/\mathcal{W}^c \rightarrow M/\mathcal{W}^c$ is chain transitive.*

Proposition 2.10. *Let $f : M \rightarrow M$ be a partially hyperbolic C^1 -diffeomorphism with a compact center foliation with finite holonomy. If f is centrally chain transitive, then f is centrally transitive.*

The proof of Proposition 2.10 relies heavily on the Shadowing Lemma 1.65 such that the statement could not be proven without the pseudo-orbit tracing property.

Clearly, Proposition 2.9 and Proposition 2.10 imply Theorem 2.7. For the elementary definitions of the Conley Theory we refer the reader to Subsection 1.3.2 in Chapter 1. We start with the proof of Proposition 2.9:

Proof. [Proposition 2.9] Let f be a partially hyperbolic C^1 -diffeomorphism with a compact center foliation \mathcal{W}^c with finite holonomy. We denote with $\text{CR}(F)$ the chain-recurrent set of F which is a union of chain-recurrent classes.

We need the following preliminary result about the chain-recurrent classes of F before we can proceed with the proof:

Lemma 2.11. *1. The induced homeomorphism $F : M/\mathcal{W}^c \rightarrow M/\mathcal{W}^c$ on the leaf space has only finitely many chain-recurrent classes.*

2. $M = \bigcup_{W^c(x) \in \text{CR}(F)} W^{cs}(x)$.

Proof. For simplicity of notation we denote the pre-image $\pi^{-1}\Omega_i \subset M$ of any chain-recurrent class $\Omega_i \subset \text{CR}(F)$ with Ω_i again as long as it does not cause confusion.

Assume there are infinitely many chain-recurrent classes. Then there is a foliated neighborhood $U \subset M$ such that Ω_1 and Ω_2 intersect U where Ω_1 and Ω_2 denote two disjoint chain-recurrent classes in $\text{CR}(F)$. We can define sets $A := \{z \in U \mid \omega(z) \in \Omega_1\}$ and $A^* := \{z \in U \mid \omega(z) \notin \Omega_1\}$. These sets are disjoint and f -invariant. Then $\Omega_1 \subset A$ and $\Omega_2 \subset A^*$. As Ω_1 and Ω_2 lie sufficiently close there exists a su -path from $x_1 \in \Omega_1$ to $x_2 \in \Omega_2$. So, there is a point $z \in W^s(x_1) \cap W^u(x_2)$. As $d(f^n z, f^n x_1) \rightarrow 0$ for $n \rightarrow \infty$ and as Ω_1 is f -invariant and closed, this implies $\omega(z) \in \Omega_1$ and hence $z \in A$. At the same time, it holds $d(f^{-n} z, f^{-n} x_2) \rightarrow 0$ for $n \rightarrow \infty$ and as Ω_2 is also f -invariant and closed, it is $\alpha(z) \in \Omega_2$. But $W^u(x_2) = W^u(z) \subset A$, contradicting the construction, and hence, $\Omega_1 = \Omega_2$. As we can cover M by finitely many foliated neighborhoods, there exist only finitely many Ω_i , $i = 1, \dots, k$ such that $\bigcup_{i=1}^k \Omega_i = \text{CR}(F)$. Now we proceed with the proof of the second item of the Lemma.

Let $x \in M$ be any point. Then $\pi\omega(x) \in \Omega \subset \text{CR}(F)$ where Ω denotes a chain-recurrent class Ω in $\text{CR}(F)$. There exists an iterate $n > 0$ such that $W^c(f^n x)$ is in a small \mathcal{W}^c -saturated neighborhood of $W^c(\omega(x))$. So the unstable leaf $W^u(y)$ for $y \in W^c(\omega(x))$ intersects the stable leaf $W^s(f^n x)$ in a point z . As $d(f^{-n} z, f^{-n} y) \rightarrow 0$ for $n \rightarrow \infty$ it follows $\alpha(z) \subset \Omega$ as Ω is closed and f -invariant. At the same time $z \in W^s(f^n x)$ and as $\omega(x) \in \Omega$ it

2.2. General lemmata

is implied $\omega(z) \in \Omega$. Consequently, $z \in \Omega$ and by $z \in W^s(f^n x)$ it follows $x \in W^{cs}(\Omega)$. \square

The following corollary is a direct implication of Lemma 2.11 and states the existence of a repeller of F :

Corollary 2.12. *There exists a chain-recurrent class $\Omega \subset \text{CR}(F)$ which is a repeller, i.e. there exists a neighborhood $U \supset \Omega$ such that $F^{-1}(\overline{U}) \subset U$ and $\bigcap_{n \geq 0} F^{-n}U = \Omega$.*

Proof. Due to Lemma 2.11 there are only finitely many chain-recurrent classes $\bigcup_{i=1}^k \Omega_i = \text{CR}(F)$. The chain-recurrent classes can be ordered by connecting orbits, i.e. $\Omega_i \leq \Omega_j$ if there exists a finite collection of chain-recurrent classes $\Omega_{k_0} = \Omega_i, \dots, \Omega_{k_l} = \Omega_j$ and points $x_0, \dots, x_l \in M$ such that $\alpha(x_n) \in \Omega_{k_{n-1}}$ and $\omega(x_n) \in \Omega_{k_n}$ for $n = 0, \dots, l$. As there are only finitely many, there exists a minimal chain-recurrent class denoted by Ω with respect to this order. Then we consider an isolating neighborhood $U \supset \Omega$. For any $x \in U$ it is $\alpha(x) \in \Omega$, because otherwise Ω would not be the minimal set. So, it is implied that $\bigcap_{n \geq 0} F^{-n}U = \Omega$ and $F^{-1}(\overline{U}) = U$, and Ω is a repeller. \square

So we consider a repeller $\pi^{-1}\Omega \subset M$ and denote it by Ω again and a neighborhood $U \supset \pi^{-1}\Omega$. Especially, $U \cap \Omega_j = \emptyset$ for any other chain-recurrent class Ω_j . For all $x \in \Omega$ it is $W^{cs}(x) \subset \Omega$. To show Proposition 2.9 we show the following Lemma:

Lemma 2.13 (Principal Lemma). *Assume there exists a repeller $\Omega \neq M$. Then there exists $y \in U$ such that $W^{cs}(y) \subset U$ and $y \notin U$.*

With this Lemma we can finish the proof of Proposition 2.9 in the following way: There exists $y \in U$ such that $W^{cs}(y) \subset U$. As $\bigcup_{W^c(x) \in \text{CR}(F)} W^{cs}(x) = M$ with Lemma 2.11 the intersection $W^{cs}(z) \cap \text{CR}(F) \neq \emptyset$. Hence, there exists $j \in \{1, \dots, k\}$ and $z \in \Omega_j$ such that $W^{cs}(z) = W^{cs}(y)$. This implies that $z \in U$ and as U is a repelling neighborhood of Ω , it is $z \in \Omega$, hence $y \in \Omega$. So we have $\Omega = M$. \square

So, we prove now the Principal Lemma 2.13 in several smaller steps:

Lemma 2.14. *There exists finitely many foliated neighborhoods $N_i \subset U$ of the center-stable foliation \mathcal{W}^{cs} , so N_i is homeomorphic to $D_i \times [-1, 1]$ where D_i is a disk of the dimension of \mathcal{W}^{cs} such that $D_i \times \{\pm 1\}$ is either contained in the interior of Ω or it lies outside of Ω .*

Proof. For any $x \in \Omega$ there exists a foliated neighborhood N_x by the local product structure of the transverse foliations \mathcal{W}^{cs} and \mathcal{W}^u . It can be chosen sufficiently small to be contained in U . Because the repeller Ω is compact, we find a finite subcover $\bigcup_{i=1}^t N_i \supset \Omega$ contained in U . As Ω is \mathcal{W}^{cs} -saturated, for any $x \in \Omega$ the whole plaque $D_i \times \{p\}$ of $x \in N_i$ is contained in Ω . Hence, either $D_i \times \{\pm 1\}$ lies entirely inside Ω or no point is contained in Ω . \square

Remark 2.15. *Suppose there does not exist a plaque $D_i \times \{\pm 1\}$ lying outside Ω then the union $\bigcup N_i$ has no boundary so $\bigcup N_i = M$. But the union $\bigcup N_i$ contains a unique chain recurrent class Ω , and hence it is $\Omega = M$, and we would have finished the proof of Proposition 2.9. So, we can assume that there exist such plaques. By changing the orientation of \mathcal{W}^u we can assume that there exists i such that $D_i \times \{1\}$ lies outside Ω .*

In these plaques $D_i \times [-1, 1]$ we choose points $m_i \in \Omega$ which are the maximal points of intersection with respect to the orientation of E^u , i.e. the set $W_+^u(m_i) = \{z \in W^u(m_i) \mid z > m_i\}$ does not intersect Ω .

Lemma 2.16. *There exists a compact set $\Delta \subset W^{cs}(m_1)$ such that*

1. Δ contains all plaques of points m_j where $m_j \in W^{cs}(m_1)$ and
2. $W^{cs}(m_1) \setminus \Delta$ is path-connected.

Proof. For any $m_k \in W^{cs}(m_1)$ there exists a stable leaf which intersects $W^c(m_k)$ and $W^c(m_1)$, hence, we can find a path γ inside this stable leaf of minimal length $c_k > 0$. As any m_k is contained in a unique plaque $D_k(m_k) \subset D_k \times [-1, 1]$, inside this plaque, the length of the stable path varies continuously and there exists a maximal length $C_k > 0$ such that all points inside $D_k(m_k)$ have a stable distance less than C_k from $W^c(m_1)$. As there are only finitely many plaques $D_k(m_k) \subset W^{cs}(m_1)$ there is a maximal $C = \max C_k$. We define Δ as the union of closed disks D^s of size C in every stable leaf inside $W^{cs}(m_1)$ which intersects a plaque $D_k(m_k)$, so it is compact as a finite union of compact sets. In every stable leaf inside $W^{cs}(m_1)$ a disk D^s of size C is removed. As every stable leaf is homeomorphic to \mathbb{R}^k with $k = \dim E^s$ and assume $k \geq 2$, $W^s \setminus D^s$ is path-connected. \square

We denote with $(x, y)^u \subset W_+^u(x)$ the open arc in the unstable leaf with $x < y$ with respect to the orientation of \mathcal{W}^u .

Lemma 2.17. *For all $x \in W^{cs}(m_1) \setminus \Delta$ there exists a unique $y \in W^u(x) \cap \Omega$ such that $(x, y)^u \cap \Omega = \emptyset$.*

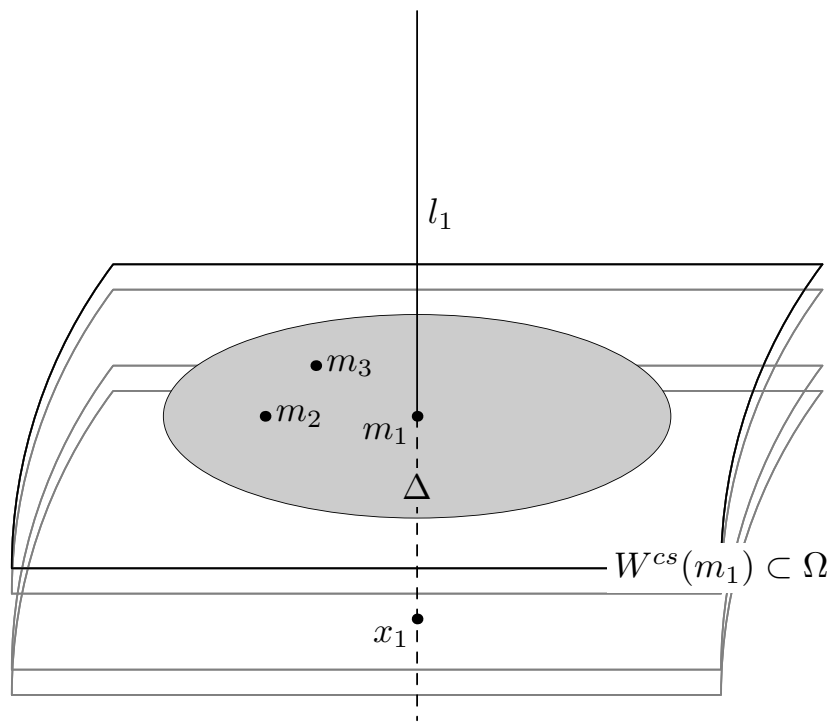

Figure 2.2: There exists a compact set $\Delta \subset W^{cs}(m_1)$ which contains all maximal points $m_1, \dots, m_t \in W^{cs}(m_1)$.

Proof. There exists some plaque $D_i \times \{p\} \subset \Omega$ with $p < 1$ such that x is contained in it. Choose the first point $y \in W_+^u(x) \cap \Omega$ - in sense of orientation of E^u . This is possible because there is no maximal point m_i inside the plaque of x . Otherwise, x would be contained in Δ . Suppose $(x, y)^u \cap \Omega \neq \emptyset$ then there would be a sequence of center-stable plaques intersecting Ω and accumulating at x , but by the holonomy of the center-stable leaves, although m_1 would be accumulated by a sequence of center-stable leaves and this contradicts that $(m_1, z)^u \cap \Omega = \emptyset$ for any $z \in W_+^u(m_1)$. Hence, $(x, y)^u \cap \Omega = \emptyset$ and the Lemma is proved. \square

For every pair of points $x_0, x_1 \in W^{cs}(m_1) \setminus \Delta$ there exists a path $\gamma \subset W^{cs}(m_1) \setminus \Delta$ with $\gamma(0) = x_0$ and $\gamma(1) = x_1$ as $W^{cs}(m_1) \setminus \Delta$ is path-connected. Locally inside a product neighborhood $D_i \times [-1, 1]$, a holonomy map $H_{x_0, x_1}^u : [x_0, y_0]^u \rightarrow [x_1, y_1]^u$ can be defined by $z \mapsto W^{cs}(z)_{loc} \cap [x_1, y_1]^u$. This holonomy is well-defined, i.e. it is independent from γ as it is defined inside a product neighborhood and the holonomy of \mathcal{W}^{cs} as a transversely orientable foliation is trivial. As $W^{cs}(m_1) \setminus \Delta$ is covered by finitely many foliated neighborhoods, we can define the holonomy between any two points $x_0, x_1 \in W^{cs}(m_1) \setminus \Delta$ following the plaques along a path γ connecting x_0 and x_1 .

Lemma 2.18. *Let $y \in W_+^u(m_1)$ be a point sufficiently close to m_1 . Then $W^{cs}(y) \subset U$.*

Proof. Let Δ' be a compact set such that $\Delta \subset \text{int}(\Delta')$. As the center-stable foliation \mathcal{W}^{cs} has only trivial holonomy, for any $y \in W_+^u(m_1)$ sufficiently close to m_1 we can push Δ' to y and obtain a homeomorphic set Δ'_y through y . We fix $y_0 \in \Delta' \setminus \Delta$, then the holonomy map $H_{y_0, x}^u$ is well-defined for any $x \in W^{cs}(m_1) \setminus \Delta$. In this way, we can complete Δ'_y to a manifold by taking $\bigcup_{x \in W^{cs}(m_1) \setminus \Delta} H_{y_0, x}^u(\tilde{y}_0)$ for $\tilde{y}_0 \in W_+^u(y_0) \cap \Delta'_y$. We get a complete manifold because if we repeat the same procedure for any other point $y_1 \in \Delta' \setminus \Delta$ we obtain exactly the same manifold. Hence, it is a complete manifold and as it is contained in $W^{cs}(y)$, it is equal to $W^{cs}(y)$. \square

To finish the proof of Theorem 2.7 we have to prove Proposition 2.10 which is a consequence of the Shadowing Lemma 1.65:

Proof. [Proposition 2.10] In the following we prove that any centrally chain transitive f under the assumptions of Proposition 2.10 is centrally transitive. This is a direct consequence of the Shadowing Lemma which we proved for partially hyperbolic diffeomorphisms with a compact center foliation with finite holonomy in Theorem 1.65: Let $\overline{\Omega(F)} \neq M/\mathcal{W}^c$, then $(M/\mathcal{W}^c) \setminus \overline{\Omega(F)}$ is an open set and for $z \in (M/\mathcal{W}^c) \setminus \overline{\Omega(F)}$ there exists $\epsilon > 0$ such that

2.3. Codimension-2 center foliation.

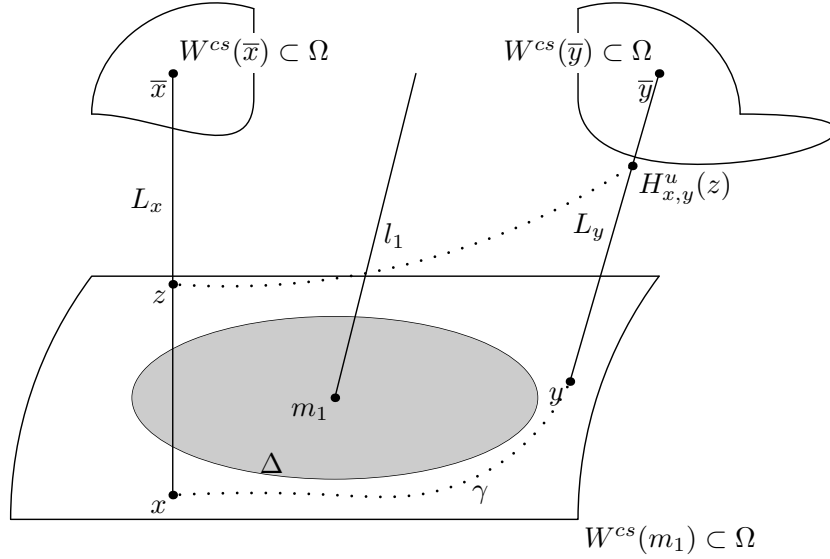

Figure 2.3: We construct a holonomy map $H_{x,y}^u : L_x \rightarrow L_y$ for any $x, y \in W^{cs}(m_1) \setminus \Delta$.

$B_\epsilon(z) \subset (M/\mathcal{W}^c) \setminus \overline{\Omega(F)}$. As F is chain-transitive, for every $\delta > 0$ we find a finite δ -chain $z_0 = z, \dots, z_k = z$ from z to z , such that $d_H(F(z_i), z_{i+1}) < \delta$ for $i = 0, \dots, k-1$. We construct a δ -pseudo orbit by defining $z_{ni} = z_i$ for all $n \in \mathbb{Z}$. By the pseudo-orbit tracing property F there exists for every $\epsilon > 0$ a $\delta > 0$ such that the finite pseudo-orbit $\{z_i\}_{i=0}^k$ is ϵ -shadowed by some point $y \in M/\mathcal{W}^c$, i.e. $d_H(F^i(y), z_i) < \epsilon$ for $i = 0, \dots, k$. Hence, it is $y \in B_\epsilon(z)$ and $f^{nk}(y) \in B_\epsilon(z)$ for all $n \in \mathbb{Z}$ contradicting that $f^k(y) \in B_\epsilon(z)$ is wandering. Hence, $\overline{\Omega(F)} = M/\mathcal{W}^c$ and F is transitive. \square

2.3 Codimension-2 center foliation.

Now we can prove Theorem *A* where both E^s and E^u are assumed to be 1-dimensional:

Let $p : \tilde{M} \rightarrow M$ be the cover of the orientations of E^s and E^u so the center-stable and center-unstable foliation are transversely orientable. The partially hyperbolic diffeomorphism f is lifted to a partially hyperbolic diffeomorphism \tilde{f} on the cover \tilde{M} . We now consider the lifted holonomies. Take the closed path γ with $\gamma(0) = \gamma(1) = x$ from above and consider the holonomy homeomorphism $H_\gamma : U \rightarrow V$ with $H_\gamma(x) = x$ along this path. Then consider a closed path $\tilde{\gamma} \subset \tilde{M}$ with $\tilde{\gamma}(0) = \tilde{x} \in p^{-1}x$ and a transversal \tilde{T} at \tilde{x} . The

lifted foliations $\tilde{\mathcal{W}}^{cs}$ and $\tilde{\mathcal{W}}^{cu}$ induce foliations $\tilde{\mathcal{T}}^s$ and $\tilde{\mathcal{T}}^u$ on \tilde{T} . Now we consider the holonomy map $\tilde{H}_{\tilde{\gamma}} : \tilde{T} \rightarrow \tilde{T}$ along $\tilde{\gamma}$. For simplicity of notation, we assume in the following that both subbundles E^s and E^u are oriented, having in mind the construction above.

Lemma 2.19. *Let $f : M \rightarrow M$ be a partially hyperbolic diffeomorphism with a compact f -invariant center foliation. Assume that $\dim E^s = \dim E^u = 1$ and that both subbundles are oriented. Then for every $x \in M$ and every $\gamma \in \pi_1(W^c(x), x)$ the generated holonomy homeomorphism is the identity, i.e.*

$$H_\gamma \equiv \text{id}.$$

Proof. As the holonomy is assumed to be a finite group, the homeomorphism H_γ is periodic on the transversal T which is homeomorphic to an open disk $\mathbb{D}^2 \subset \mathbb{R}^2$. Then - applying Lemma 1.14 - H_γ is topologically conjugate either to a rotation by $\frac{2\pi}{n}$ or to $-\text{id}$. Since - following Lemma 2.3 - it holds $H_\gamma|_{T_x^u} \equiv \text{id}$ and - with the same argument as \mathcal{W}^{cu} is a transversely oriented codimension-1 foliation - $H_\gamma|_{T_x^s} \equiv \text{id}$, the two axis are fixed by H_γ it must be homeomorphic to the identity. \square

In the following we show that any non-trivial holonomy homeomorphism reverses the orientation of the stable and unstable bundle at the same time and is therefore a rotation by π . For this step we need the density of the center-unstable leaves. In order to obtain this result we consider the leaf space $\tilde{M}/\tilde{\mathcal{W}}^c$ of the lifted center foliation which is a 2-torus and show that the induced map F on this space is conjugate to a hyperbolic toral automorphism and that therefore the induced unstable leaves are dense in the leaf space.

Theorem 2.20. *Let $f : M \rightarrow M$ be a partially hyperbolic diffeomorphism with a compact f -invariant center foliation. Assume that $\dim E^s = \dim E^u = 1$ and that both subbundles are oriented. Then the leaf space $S := M/\mathcal{W}^c$ is a 2-torus.*

Proof. Because the center-stable and center-unstable foliations \mathcal{W}^{cs} and \mathcal{W}^{cu} are transversely orientable and of codimension 1 the center-stable and center-unstable holonomies H^u and H^s are trivial. This implies that the center foliation \mathcal{W}^c has trivial holonomy, as shown in Lemma 2.19 above. The quotient space $S := M/\mathcal{W}^c$ is therefore a compact topological surface. The foliations \mathcal{W}^{cs} and \mathcal{W}^{cu} are subfoliated by the stable and center foliation and the unstable and center foliation respectively, so they induce two topological oriented foliations \mathcal{W}^s and \mathcal{W}^u on S as explained in more detail in the introductory

2.3. Codimension-2 center foliation.

subsection 1.3.1. Therefore S is an oriented compact and connected surface. As there exists a codimension-1 foliation on S , the Euler characteristic of S has to be zero (cp. [Thu76]) and as it is oriented it has to be the 2-torus. \square

Corollary 2.21. *The induced map $F : S \rightarrow S$ is conjugate to a hyperbolic toral automorphism.*

Proof. The induced map F is expansive as it is shown in Theorem 1.37. Lewowicz has shown in [Lew89] that every expansive homeomorphism of a 2-torus is conjugate to a hyperbolic toral automorphism. \square

In the following we do not assume that E^s or E^u are oriented. Now we can proceed to show that any non-trivial holonomy homeomorphism of \mathcal{W}^c is conjugate to a rotation by π . We define a set A of all center leaves with a holonomy homeomorphism reversing the orientation of E^s and preserving the orientation of E^u and show that A is empty. As a first step we prove that A coincides locally with T_x^u . So we define the set

$$A := \left\{ W^c(x) \mid \exists \gamma \subset W^c(x) \text{ closed path : } \begin{array}{l} E^s \text{ not oriented along } \gamma, \\ E^u \text{ oriented along } \gamma \end{array} \right\}.$$

Lemma 2.22. *Let $f : M \rightarrow M$ be a partially hyperbolic diffeomorphism with a compact f -invariant center foliation. Assume that $\dim E^s = \dim E^u = 1$. Then the set A as defined above is empty.*

Proof. We consider the 2-fold covering $p : \tilde{M}^u \rightarrow M$ of orientation of E^u and define

$$\begin{aligned} \tilde{A} &:= \left\{ \tilde{W}^c(x) \mid \exists \tilde{\gamma} \subset \tilde{W}^c(x) : \begin{array}{l} E^s \text{ not oriented along } \tilde{\gamma} \end{array} \right\} \\ &= \left\{ \tilde{W}^c(x) \mid \left| \text{Hol} \left(\tilde{W}^c(x) \right) \right| = 2 \right\}. \end{aligned}$$

It is $p\tilde{A} = A$, and it contains all center leaves with a holonomy group isomorphic to \mathbb{Z}_2 and therefore of maximal order. So we can apply Lemma 2.5 and conclude that \tilde{A} is a \tilde{f} -invariant, closed set and $\tilde{T}_x^u \subset \tilde{A}$ for any $x \in \tilde{A}$. By applying the Reeb Stability Theorem 1.6 there exists a saturated neighborhood \tilde{V} of $\tilde{W}^c(x)$ and we consider a point $y \in \tilde{V} \setminus \tilde{T}_x^u$. Because of the local product structure and $\tilde{T}_x^u \subset \tilde{A}$ we can assume that $y \in T_x^s$ for some $x \in \tilde{A}$. Then $p : \tilde{W}^c(y) \rightarrow \tilde{W}^c(x)$ is a cover and the holonomy group $\text{Hol}(W^c(y))$ equals the subgroup of $\text{Hol}(W^c(x))$ whose elements fix $W^c(y)$. But as any non-trivial holonomy homeomorphism of $\text{Hol}(W^c(x))$ reverses the orientation of E_x^s , the center leaf $W^c(y)$ is only fixed by the trivial subgroup, hence it is itself trivial and the cover p is 2-fold. Accordingly, $y \notin \tilde{A}$.

This implies that the set A coincides in a neighborhood with the local unstable manifold $W_{loc}^u(W^c(x))$. Because the projected map $F : S \rightarrow S$ of f is conjugate to a hyperbolic toral automorphism - as shown in Corollary 2.21 -, the projection of every center-unstable leaf $\pi W^{cu}(x)$ is dense in M/\mathcal{W}^c . Therefore and since A is a \mathcal{W}^c -saturated set A itself must be dense in T , so $A = T$ is implied. But at the same time, \tilde{A} coincides locally with \tilde{T}_x^u and no other point in the neighborhood is contained in \tilde{A} , therefore \tilde{A} must be empty, and also A . \square

The analogous statement holds for the set

$$A' := \{W^c(x) \mid \exists \gamma \text{ path on } W^c(x) : E^u \text{ not oriented along } \gamma, \\ E^s \text{ oriented along } \gamma\}.$$

Consider an arbitrarily chosen holonomy homeomorphism $H : T \rightarrow T$ at $x \in M$ with period $n > 1$. Then according to Theorem 1.14 either H is orientation-preserving and fixes only a single point or H is orientation-reversing and the set of fixed points is a simple arc which divides T into two topological discs which are permuted by H . Since H preserves the foliations \mathcal{T}^s and \mathcal{T}^u there cannot exist an arc not equal T_x^s or T_x^u . Since we have shown in Lemma 2.22 that there cannot be H such that T_x^s is fixed but T_x^u not, H must be orientation-preserving and only x is fixed by H . All non-trivial holonomy groups are therefore generated by a homeomorphism that is conjugate to a rotation by π . As the fixed point of any non-trivial homeomorphism is a single point the center leaves with non-trivial holonomy are isolated.

By Lemma 2.19 we conclude that any non-trivial holonomy group is isomorphic to \mathbb{Z}_2 generated by a rotation by π . The leaf space M/\mathcal{W}^c is a compact 2-orbifold with a manifold cover by the 2-torus. So it is implied that the Euler characteristic $\chi(M/\mathcal{W}^c)$ of M/\mathcal{W}^c is also zero. On the other hand we can calculate the Euler characteristic of the orbifold, also known as the Riemann-Hurwitz formula, by

$$\chi(M/\mathcal{W}^c) = \chi(X) - \sum_{i=1}^n \left(1 - \frac{1}{p_i}\right),$$

where X is the underlying space of the orbifold with n elliptic points of order p_i . We have $p_i = 2$ for every elliptic point, so we get $\chi(X) = \frac{n}{2}$. Because of the classification of compact surfaces by its Euler characteristic we can conclude that either $n = 0$ and $X = M/\mathcal{W}^c$ is \mathbb{T}^2 or $n = 4$ and $X = \mathbb{S}^2$. The last statement of Theorem A - the existence of a 2-fold cover such that all center holonomy is eliminated, the quotient map onto the leaf space defines a fiber bundle over \mathbb{T}^2 and \tilde{f} projects onto a linear Anosov automorphism - was established during the proof above.

Example 2.23 ([BW05a]). *Recall Example 1.39 above. Now we have seen that it represents a very typical example of a 3-dimensional partially hyperbolic system with compact center leaves with non-trivial holonomy.*

Let \mathbb{T}^3 be the usual compact 3-torus. Define an action S of \mathbb{Z}_2 on \mathbb{T}^3 by $(x, y, z) \mapsto (-x, -y, z + \frac{1}{2})$.

Then the quotient $M := \mathbb{T}^3 / (x, y, z) \sim S(x, y, z)$ is a compact smooth 3-manifold. It is a \mathbb{S}^1 -bundle $\pi : M \rightarrow B$ over a 2-orbifold B with fibers $\pi^{-1}(x) \cong \{x\} \times \mathbb{S}^1$. The space B is not a manifold because there are four singular leaves corresponding to the fix points of the action of \mathbb{Z}_2 on \mathbb{T}^2 : $(0, 0), (0, \frac{1}{2}), (\frac{1}{2}, 0), (\frac{1}{2}, \frac{1}{2})$. The holonomy group of these four leaves is nontrivial. The orbifold B looks like \mathbb{S}^2 with four singular points.

On the 3-manifold M there exists a partially hyperbolic system $F_\phi : M \rightarrow M$ defined in the following way: Take a product of a linear Anosov map

$A : \mathbb{T}^2 \rightarrow \mathbb{T}^2$ and a rotation $z \mapsto \phi(z) + \frac{1}{2}$ where ϕ is a symmetric map: $\phi \circ (-\text{id}) = \phi$ such that this product commutes with the action of S on M : $F_\phi \circ S = S \circ F_\phi$. The center foliation is $\{\{x, y\} \times \mathbb{S}^1 / (x, y, z) \sim S(x, y, z)\}$ of \mathbb{T}^3 under the group action of \mathbb{Z}_2 . It is a compact foliation with finite holonomy groups.

2.4 Codimension-3 center foliation

In the next Theorem B we consider the case of a codimension-3 center foliation. We assume a f -invariant compact center foliation with finite holonomy. We lift the system $f : M \rightarrow M$ to the 4-fold orientation cover \tilde{M} of E^u and E^s to a partially hyperbolic system $\tilde{f} : \tilde{M} \rightarrow \tilde{M}$. We define as above the set A of all center leaves with a holonomy group of maximal order. We show that this set equals \tilde{M} and that therefore any holonomy group \tilde{H}^s of the center-unstable foliation and any holonomy group \tilde{H}^u of the center-stable foliation is trivial in the 4-fold cover \tilde{M} .

The bundles E^s and E^u are oriented.

Lemma 2.24. *Let $f : M \rightarrow M$ be a partially hyperbolic C^1 -diffeomorphism with a f -invariant compact center foliation \mathcal{W}^c with finite holonomy. Assume $\dim E^s = 2$ and $\dim E^u = 1$ and that both bundles are oriented. Then every center leaf has trivial holonomy.*

Proof. We define the set

$$A := \left\{ x \in M \mid |\text{Hol}(W^c(x))| = \max_{y \in M} |\text{Hol}(W^c(y))| \right\}$$

and show that it is M and that therefore the maximal order of holonomy is one. As the center-stable foliation \mathcal{W}^{cs} is a transversely oriented codimension-1 foliation, its holonomy group H^u is everywhere trivial and therefore the set A is \mathcal{W}^{cu} -saturated as shown in more detail in Lemma 2.5 above. By Theorem 1.33 any center-unstable leaf is non-compact. Let $W^{cu}(x) \subset A$ for some $x \in M$. Because $W^{cu}(x)$ is non-compact it accumulates at $z \in M$ and as A is closed, $W^c(z) \subset A$. Consider a foliated neighborhood U of z and the holonomy group $\text{Hol}(W^c(z))$ of $W^c(z)$. Any holonomy homeomorphism $H_\gamma \in \text{Hol}(W^c(z))$ has the representation $H_\gamma = H_\gamma^s \times H_\gamma^u$ where $H_\gamma^u \equiv \text{id}$. Consider a smooth embedding $T := \phi(\mathbb{D}^2) \subset U$ of $\mathbb{D}^2 \subset \mathbb{R}^2$ such that T is transverse to $W^{cu}(z)$. Then assuming H_γ^s to be non-trivial, $H_\gamma^s : T \rightarrow T$ has either a single isolated fixed point and is orientation-preserving or it has an arc of fixed points and is orientation-reversing. As $W^{cu}(x)$ is non-compact there are infinitely many plaques intersecting T and its intersection points are accumulating at z . As $W^c(z) \subset A$, the order of the holonomy group of $W^c(z)$ is maximal and equal to the order of the holonomy group of $W^c(x)$, accordingly, every intersection point must be fixed by the whole holonomy group of $W^c(z)$. Therefore H_γ^s has to have an arc of fixed points and is therefore orientation-reversing, but this is a contradiction to the assumption that E^s is oriented. Therefore H_γ^s has to be the identity, and any holonomy group in M is trivial. □

The unstable bundle E^u is oriented. From now on we consider the 2-fold orientation cover \tilde{M}^u of E^u and the lifted partially hyperbolic system $\tilde{f} : \tilde{M}^u \rightarrow \tilde{M}^u$. As we have shown in Lemma 2.24 above the maximal order of holonomy in \tilde{M}^u is 2 and every holonomy group is, if not trivial, generated by a 2-periodic holonomy homeomorphism in H^s . We show that the set

$$A := \{W^c(x) \mid |\text{Hol}(W^c(x))| = 2\}$$

of leaves with non-trivial holonomy group is empty. This is done in several smaller lemmata. So, first we prove the following:

Lemma 2.25. *Let E^u be oriented and $\dim E^u = 1$. Lifted to the orientation cover \tilde{M}^s of E^s the connected components of \tilde{A}/\tilde{W}^c are 2-tori. Every torus T is invariant under F , and $F|_T$ is conjugate to a linear Anosov map.*

Proof. The set A is \mathcal{W}^{cu} -saturated and closed as shown in Lemma 2.5. Assume that A is non-empty and $W^{cu}(x) \subset A$ for some $x \in M$. As the center-unstable leaf $W^{cu}(x)$ is non-compact it accumulates at a point $z \in M$,

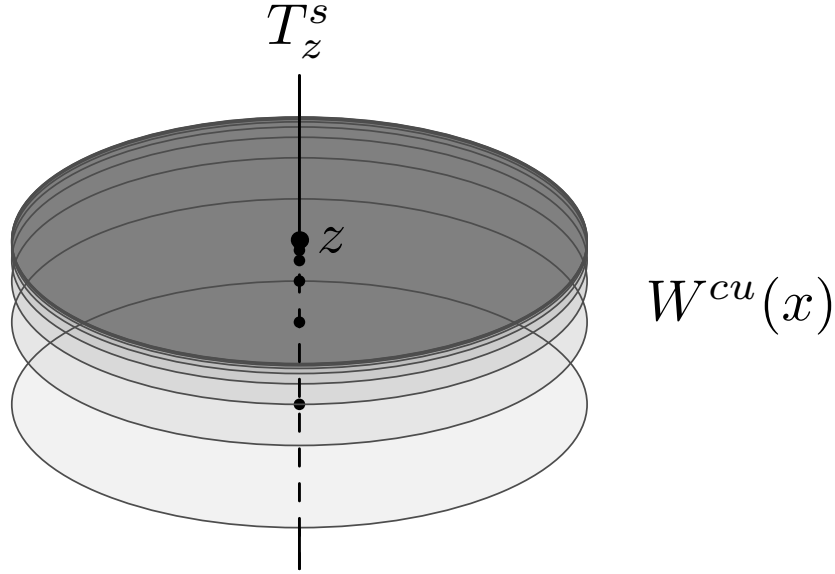

Figure 2.4: Unstable plaques of $W^{cu}(x)$ are accumulating at z , i.e. the intersection points $W^{cu}(x) \cap T_z^s$ accumulates at z

and $W^c(z) \subset A$ because A is closed. We consider the holonomy group $\text{Hol}(W^c(z))$ which is isomorphic to \mathbb{Z}_2 . Therefore there is a closed path $\gamma \subset W^c(z)$ which generates the subgroup of all non-trivial holonomy homeomorphisms H_γ^s . Infinitely many plaques of the center-unstable leaf $W^{cu}(x)$ intersect T_z^s accumulating at z , hence the subgroup generated by H_γ^s has a line segment Σ of fixed points as argued in Lemma 2.24, and $\Sigma \subset A$ is implied. This holds for any $x \in A$ and therefore we get a foliation of A by stable lines. Further, A is foliated by W^{cu} .

We lift A to the 2-fold cover \tilde{A} of orientation of E^s . Then $\tilde{A}/\tilde{\mathcal{W}}^c$ is a compact surface foliated by two one-dimensional foliations. Hence, every connected component \tilde{A}_0 of $\tilde{A}/\tilde{\mathcal{W}}^c$ has Euler characteristic zero and is by Thurston in [Thu76] the 2-torus or the Klein bottle. But any foliation of the Klein bottle has a compact leaf as it is shown by H. Kneser in [Kne24]. Because the one-dimensional unstable foliation on $\tilde{A}_0/\tilde{\mathcal{W}}^c$ has no compact leaf we conclude that $T := \tilde{A}_0/\tilde{\mathcal{W}}^c \cong \mathbb{T}^2$.

Since A is f -invariant, the set $\tilde{A}/\tilde{\mathcal{W}}^c$ is invariant under F . Both foliations are also invariant under F because the order of holonomy is constant along a f -orbit and coincides with the stable and unstable equivalence classes with respect to $F|_{\tilde{A}/\tilde{\mathcal{W}}^c}$. The finitely many tori $T \subset \tilde{A}/\tilde{\mathcal{W}}^c$ are interchanged by F and consequently, there is k such that $F^k : T \rightarrow T$ is a homeomorphism for

any torus T . As F is expansive, $F^k|_T$ is expansive and it is conjugate to a linear Anosov map on $\tilde{A}/\tilde{\mathcal{W}}^c$. □

The transitivity of F and Lemma 2.25 imply that the set A is empty:

Corollary 2.26. *The set A is empty.*

Proof. Consider the 2-cover \tilde{M}^s of the orientation of E^s . There exist tori $T \subset V := \tilde{M}/\tilde{\mathcal{W}}^c$ as shown in Lemma 2.25 above that are invariant under F^k and $F^k|_T$ is conjugate to a linear Anosov map. In Theorem 2.7 it is shown that F is transitive, and therefore we can apply Theorem 1.47 by Vieitez and conclude that the manifold V is a 3-torus. Further, due to Theorem 1.48 by Hiraide, the homeomorphism F is conjugate to a hyperbolic automorphism, and so is F^k . Hence, any F^k -invariant connected set is either a point or the whole 3-torus (cp. [Hir71]). Therefore there can't exist any F^k -invariant 2-tori in V , and A is empty. □

The bundles E^u and E^s are not oriented. We have shown above that in the orientation cover of E^u the lifted center leaves have only trivial holonomy. It remains to prove that the center leaves with non-trivial holonomy are isolated and what the non-trivial holonomy homeomorphisms look like.

Lemma 2.27. *Let $f : M \rightarrow M$ be a partially hyperbolic C^1 -diffeomorphism with an invariant compact center foliation with finite holonomy. Assume $\dim E^u = 1$ and $\dim E^s = 2$. Then the center leaves with non-trivial holonomy are isolated.*

Proof. We have shown above in Corollary 2.26 that the only non-trivial homeomorphisms of the center foliation are of period 2 and reverses the orientation of the unstable bundle. Denote such a non-trivial homeomorphism along a closed curve γ with $\gamma(0) = x$ by $H_\gamma = H_\gamma^s \times H_\gamma^u$. The homeomorphism $H_\gamma^u : T_x^u \rightarrow T_x^u$ has the single point x as fixed point while the homeomorphism $H_\gamma^s : T_x^s \rightarrow T_x^s$ by Theorem 1.14 is either the identity, a rotation by π or a reflection. First, we show that $|H^u| = |H^s| = 2$. Then we have to show that any H_γ^s is a rotation by π and cannot be a reflection what implies that the leaves with non-trivial holonomy are isolated.

Lemma 2.28. *Let $f : M \rightarrow M$ be a partially hyperbolic C^1 -diffeomorphism with an invariant compact center foliation with finite holonomy. Assume $\dim E^u = 1$ and that for any holonomy group $H = (H^s, H^u)$ it is $|H^s| \leq |H^u| = 2$. Then it holds $|H^s| = |H^u|$.*

Proof. For this purpose we define the set

$$A := \{x \in M \mid |H^s| < |H^u| = 2\}.$$

It is a f -invariant set in M . The set is locally saturated by center-stable leaves, i.e. for any $x \in A$ there exists a neighborhood $U_x \subset W^s(x)$ such that $U_x \subset A$. We show that the boundary of this neighborhood U_x is also contained in A . For this reason take a sequence $(x_n)_{n \in \mathbb{N}}$ with $x_n \in U_x$ converging to $y \in \partial U_x$. Then for sufficiently big $n \in \mathbb{N}$ the center leaf $W^c(x_n)$ is a cover $p : W^c(x_n) \rightarrow W^c(y)$ of $W^c(y)$. Consider a closed path $\gamma \in \pi_1(W^c(x_n), x_n)$ such that $H_\gamma^u \not\equiv \text{id}$ and $H_\gamma^s \equiv \text{id}$. Then the path $\gamma * := p_\# \gamma \in \pi_1(W^c(y))$ and because $H_\gamma^s \equiv \text{id}$, the interior of the set of fixed points of the holonomy homeomorphism $H_{\gamma*}^s$ is not empty. Applying Theorem 1.16 we get $H_{\gamma*}^s = \text{id}$. As the orientation of E^u is a continuous property the holonomy homeomorphism $H_{\gamma*}^u$ has to reverse the orientation of E^u , too. This implies that $y \in A$ and A is therefore closed in \mathcal{W}^s and \mathcal{W}^{cs} -saturated. The center-stable leaf $W^{cs}(x)$ as a non-compact leaf has to accumulate at a point $z \in M$ and $W^c(z) \subset A$ as A is closed in \mathcal{W}^{cs} . Consider the holonomy group of $W^c(z)$. The embedded one-dimensional disk $T = \phi(\mathbb{D}^1)$ transversal to $W^{cs}(z)$ is intersected by infinitely many plaques of $W^{cs}(x)$ which are accumulating at z such that any holonomy homeomorphism $H_\gamma^u : T \rightarrow T$ has to be the identity. Therefore the group H^u of $W^c(z)$ has to be trivial contradicting $W^c(z) \subset A$, and A has to be the empty set. \square

In the following we exclude the possibility that the holonomy acts as a reflection in the stable direction.

For this purpose we suppose that there exists a non-trivial homeomorphism $H_\gamma = H_\gamma^s \times H_\gamma^u$ of the center foliation which reverses the orientation of the stable and unstable bundle at the same time. The homeomorphism $H_\gamma^u : T_x^u \rightarrow T_x^u$ has the single point x as fixed point while the homeomorphism $H_\gamma^s : T_x^s \rightarrow T_x^s$ by Theorem 1.14 has a line segment $\sigma \subset W^{cs}(x)$ as set of fixed points.

Therefore σ is the set of fixed points of H_γ . As the holonomy along this set is of maximal order σ is closed, and it is f -invariant. We show that σ has to be bounded and therefore compact:

Lemma 2.29. *The set σ of fixed points with maximal holonomy is bounded.*

Proof. Assume $\sigma \subset W^{cs}(x)$ is unbounded. As M is compact, the set σ accumulates at a point $z \in M$ such that σ intersects the local transversal T_z^u infinitely many times. So consider the holonomy of $W^c(z) \subset \sigma$. Any non-trivial holonomy homeomorphism $H_\gamma^u : T_z^u \rightarrow T_z^u$ has a single isolated

fixed point and is orientation-reversing but this is a contradiction to $\sigma \cap T_z^u$ accumulating at z . Therefore σ is bounded. \square

The set σ is compact and f -invariant. It may consist of several connected components which are interchanged by f . So consider one connected component σ_0 with positive length $l(\sigma_0) > 0$. As σ lies inside the stable foliation, the length of the component σ_0 is stretched under the action of f^{-1} . So the length $l(f^{-n}\sigma_0)$ tends to infinity. But now the same argument as above can be applied.

So we can conclude that any non-trivial holonomy homeomorphism acts as a reflection in the unstable direction and a rotation by π in the stable direction and therefore the center leaves with non-trivial holonomy are isolated. Any non-trivial holonomy homeomorphism is topologically conjugate to $-\text{id}$. \square

We now prove the last statement:

Lemma 2.30. *Any non-trivial holonomy homeomorphism H of $W^c(x)$ for any $x \in M$ is equal to $-\text{id}$.*

Proof. We already know that the holonomy group of any center leaf $W^c(x)$ with non-trivial holonomy is isomorphic to \mathbb{Z}_2 and that any non-trivial holonomy homeomorphism H is conjugate to $-\text{id}$. The map H is orientation-reversing in the unstable direction and 2-periodic. First, assume that E^u is oriented, then the leaf space M/\mathcal{W}^c is \mathbb{T}^3 and F is conjugate to a linear Anosov map A . Clearly, the map A is transitive. We can therefore conclude that there exists a transverse measure $\mu = \{\mu_I\}$, the Margulis measure, for the stable foliation \mathcal{W}^s which is invariant under holonomy and which is positive on non-empty open intervals and finite on finite subsets of unstable leaves. It is maximizing the entropy of A . As the map A acts expanding along every unstable leaf $W^u(x)$ and every unstable leaf is one-dimensional it is uniquely - up to renormalization by a constant factor - defined to be the Lebesgue measure. It is further H -invariant, and hence, H is identical with $-\text{id}$. As any unstable leaf is dense and the holonomy homeomorphism H is continuous H has to be $-\text{id}$ everywhere. \square

Remark 2.31. *The last Lemma 2.30 holds also in the case of a one-dimensional unstable bundle E^u .*

2.5 Codimension-(1+k) center Foliation

In the case of a codimension-2 and codimension-3 center foliation we could utilize that under the dynamical assumptions of the respective theorems the

leaf space is known to be a 2-torus and 3-torus. But in higher codimension there is no such a theorem in the topological case. In 1970, Franks showed in [Fra70] that any transitive Anosov diffeomorphism with a one-dimensional unstable direction is conjugate to a hyperbolic toral automorphism. Combined with the result by Newhouse in [New70] that any Anosov diffeomorphism with a one-dimensional unstable direction is transitive we conclude that any Anosov diffeomorphism with a one-dimensional unstable direction is conjugate to a hyperbolic toral automorphism. We have already proved in Theorem 2.7 the central transitivity of f which is part (1) of Theorem C. It remains to prove the theorem by Franks to the case of a topological, non-differentiable hyperbolic map on a topological manifold.

Proof of Theorem C(2). We can proceed directly with the proof of Theorem C (2) and show that the holonomy of every center leaf is trivial if the unstable bundle E^u is one-dimensional and oriented and that otherwise center leaves with non-trivial holonomy are isolated. Further it is shown that every non-trivial holonomy homeomorphism is conjugate to $-\text{id}$. Recall that it is shown in Theorem 1.32 that f is dynamically coherent. Consider a local transversal T at x to $W^c(x)$ and the foliations \mathcal{T}^s and \mathcal{T}^u induced by \mathcal{W}^{cs} and \mathcal{W}^{cu} respectively on T . We define the set

$$A := \left\{ W^c(x) \mid |\text{Hol}(W^c(x))| = \max_{y \in M} |\text{Hol}(W^c(y))| \right\}$$

of center leaves with holonomy of maximal order. This set is non-empty as $x \in M \mapsto |\text{Hol}(W^c(x))|$ is locally upper-semicontinuous and M is compact. We have shown in Lemma 2.5 that A is \mathcal{W}^{cu} -saturated, closed and f -invariant.

Lemma 2.32. *Let $f : M \rightarrow M$ be a centrally transitive partially hyperbolic C^1 -diffeomorphism with a f -invariant compact center foliation. Assume $\dim E^u = 1$ and E^u to be oriented. Then the holonomy of any center leaf is trivial.*

Proof. As f is centrally transitive, we can find a dense positive orbit $\{W^c(f^n x)\}_{n \geq 0}$ of center leaves.

Lemma 2.33. *Let $\{W^c(f^n x)\}_{n \geq 0}$ be a dense orbit of center leaves. For all $y \in \mathcal{W}^s(\bigcup_{n \geq 0} W^c(f^n x))$ the forward orbit of center leaves $\bigcup_{n \geq 0} W^c(f^n y)$ is dense in M .*

Proof. Consider $y \in \mathcal{W}^s(\bigcup_{n \geq 0} W^c(f^n x))$. Then there exists for some $n \geq 0$ a point $w \in W^c(f^n x)$ such that $W^s(y) = W^s(w)$. As w and y lie on a common stable leaf the center leaves $W^c(y)$ and $W^c(w)$ converge to each other with respect to the Hausdorff metric. So we find $N \geq 0$ such that $d_H(W^c(f^n y), W^c(f^n w)) < \frac{\epsilon}{2}$ for all $n \geq N$. Let $B(z, \epsilon) \subset M$ be a non-empty open ball around an arbitrarily chosen point $z \in M$. As the orbit of center leaves $\bigcup_{n \geq 0} W^c(f^n w)$ is dense in M the orbit $\bigcup_{n \geq N} W^c(f^n w)$ is still dense and we find $m \geq N$ such that $W^c(f^m w) \cap B(x, \frac{\epsilon}{2}) \neq \emptyset$ and hence $W^c(f^m y) \cap B(x, \epsilon) \neq \emptyset$. \square

Choose an arbitrary point $y \in A$ then there exists $n \in \mathbb{N}$ such that sufficiently close to y there is a point $z \in W^c(f^n x)$. Then there is a non-empty intersection $W^u(y) \cap W^{cs}(z) \ni [z, y]$. The point $[z, y]$ is contained in A as A is \mathcal{W}^{cu} -saturated and $[z, y] \in W^{cs}(f^n x)$. So A contains a point $[z, y] \in \mathcal{W}^s(\bigcup_{n \geq 0} W^c(f^n x))$ and therefore the whole orbit of center leaves which is dense according to Lemma 2.33. The set A is therefore the whole manifold M . As leaves with trivial holonomy are generic, this implies that the maximal order of holonomy groups is one and all center leaves have trivial holonomy. \square

We have just showed that the holonomy of every center leaf lifted to the orientation cover of E^u is trivial. The last step to finish the proof of part 2 is to show that every non-trivial holonomy of every center leaf in M , not in the cover, has order 2 and has only isolated fixed points. We have already shown that the order $|H^s|$ of the holonomy group of any center-unstable leaf is always less equal than the order $|H^u|$ of the holonomy group of any center-stable leaf. As the center holonomy is trivial on a 2-fold cover, every holonomy group has at most order two. We can apply Lemma 2.28 to conclude that for any holonomy group $H = (H^s, H^u)$ it holds $|H^s| = |H^u|$. So we only have to show that every non-trivial holonomy homeomorphism has only isolated fixed points.

Lemma 2.34. *Let $f : M \rightarrow M$ be a partially hyperbolic C^1 -diffeomorphism with an invariant compact center foliation with finite holonomy. Assume $\dim E^u = 1$. Then the center leaves with non-trivial holonomy are isolated.*

Proof. We have shown above that the only non-trivial homeomorphism of the center foliation is of period 2 and reverses the orientation of the unstable bundle. We define as usually the set A of all center leaves $W^c(x)$ with a non-trivial holonomy group of order 2.

So we know that any non-trivial holonomy group $\text{Hol}(W^c(x))$ is isomorphic to \mathbb{Z}_2 . So there exists a closed path γ with $\gamma(0) = x$ which generates

the non-trivial holonomy homeomorphisms and we denote such a non-trivial holonomy homeomorphism by $H_\gamma = H_\gamma^s \times H_\gamma^u$. The orientation-reversing homeomorphism $H_\gamma^u : T_x^u \rightarrow T_x^u$ has the single point x as fixed point. We assume that $H_\gamma^s : T_x^s \rightarrow T_x^s$ has non-isolated fixed points, especially x is non-isolated. So there exists a sequence $\{z_n\}_{n \in \mathbb{N}} \subset T_x^s$ of fixed points converging to $x \in T_x^s$. We take a ball $B_r^s(x) \subset W^s(x)$ with sufficiently small $r > 0$ such that it is contained in T_x^s . Then we consider $f^{-n}B_r^s(x)$ with $n \in \mathbb{N}$. For any n the fixed points $f^{-n}z_k$ are still converging to $f^{-n}x$ for $k \rightarrow \infty$. Hence, we find n sufficiently large such that $f^{-n}B_r^s(x)$ lies inside infinitely many plaques of $W^{cs}(f^{-n}x)$ accumulating at $f^{-n}(x)$. So $T_{f^{-n}x}^u$ is intersected infinitely many times by these plaques. The set A of center leaves with maximal holonomy is a closed and f -invariant set, such that $f^{-n}x \in A$ and the intersection points are fixed points of the whole holonomy group. Consequently, the holonomy homeomorphism $H^u : T_{f^{-n}x}^u \rightarrow T_{f^{-n}x}^u$ has to be the identity. At the same time, the order of the holonomy group is constant along a f -orbit contradicting the assumption.

So we can conclude that the center leaves with non-trivial holonomy are isolated. \square

Proof of Theorem C(3). Now we proceed with the proof of Theorem C(3) and show that the leaf space is homeomorphic to a q -torus and F is conjugate to a hyperbolic toral automorphism if E^u is one-dimensional and oriented.

From now on, we assume an oriented unstable bundle E^u . Accordingly, the center foliation \mathcal{W}^c has only trivial holonomy, and the leaf space is a compact topological manifold. We prove Theorem C(3) in two parts:

1. We establish in the following Theorem 2.35 the existence of a family of non-atomic measures on the center-unstable leaves.
2. With the help of this transverse measure we can prove Theorem C(3) by following a proof by Hiraide of Franks' Theorem in [Fra70] which states that any transitive Anosov diffeomorphism $f : M \rightarrow M$ with a codimension-1 stable foliation is conjugate to a hyperbolic toral automorphism. This is the content of Theorem 2.54.

Hiraide presents in [Hir01] a simpler proof than the original by Franks, mainly by using the existence of a transverse holonomy-invariant measure. Its existence is well-known in the case of a transitive Anosov-diffeomorphism but we have to construct it by hand for our special setting.

Construction of the Margulis measure. We start with the construction of the Margulis measure, a family of non-atomic measures with support in the center-unstable leaves.

Theorem 2.35. *Let $f : M \rightarrow M$ be a partially hyperbolic system with a compact f -invariant center foliation with finite holonomy. Suppose that E^u is oriented and one-dimensional. Then there exists a family of measures $\mu^{cu} := \{\mu_A^{cu}\}$ where $A \subset W^{cu}(x)$ is any \mathcal{W}^c -saturated open set with compact closure for some $x \in M$ with the following properties:*

1. *Every measure μ_A^{cu} is a non-atomic measure that is positive on non-empty open \mathcal{W}^c -saturated sets inside a center-unstable leaf.*
2. *Every measure μ_A^{cu} is expanding under the induced action of f .*
3. *The family of measures is invariant under the holonomy along stable leaves.*

Remark 2.36. *Owing to Theorem C(1),(2) we know that f is centrally transitive and that the center foliation has only trivial holonomy under the assumptions of Theorem 2.35.*

Without loss of generality we can assume in the following that f is C^∞ : We can perturb f a bit to obtain an arbitrarily smooth f without changing the implications for the topological properties of F . As F is shown to be conjugate to a hyperbolic toral automorphism F_A it is structurally stable and every sufficiently small perturbation is conjugate to F .

Proof. [Theorem 2.35] We follow the construction of the Margulis measure in [Mar70] and in [HK95].

The road map of the construction is the following:

1. The measure μ_A^{cu} is constructed with the help of the Riesz Representation Theorem by

$$\tilde{L}(\phi) = \int \phi d\mu_A^{cu}(x)$$

where $\phi \in C_c(U)$ is a continuous function whose compact support is contained in an open \mathcal{W}^c -saturated set $U \subset W^{cu}(x)$ and \tilde{L} is a certain linear functional inside some compact subspace of the dual space C^* .

2. First, we have to construct a set C of continuous functions, a dual space C^* and a compact subspace $\overline{C}_2^* \subset C^*$. The function space $C_c(U)$ will be a subset of C .

2.5. Codimension-(1+k) center Foliation

3. Second, we construct a continuous map $\tilde{f} : \overline{C}_2^* \rightarrow \overline{C}_2^*$ such that the linear functional \tilde{L} is the fixed point of this map:

$$\tilde{f}\tilde{L} = \tilde{L}.$$

4. At the end, we can show the required properties (1)-(3) of the measure μ_A^{cu} .

Before we start with the construction of the measure we prove three preliminary lemmata which are used several times during the construction to obtain certain bounds for linear functionals and to show the continuity of the map \tilde{f} .

For every $x \in M$, the center-unstable leaf $W^{cu}(x)$ is a submanifold of M and as such it has a metric d_{cu} and a smooth Lebesgue measure λ_{cu} . We use the Hausdorff metric d_H^{cu} on the set of compact center leaves in one center-unstable leaf $W^{cu}(x)$, this means for any $x, y \in W^{cu}(x)$ it is $d_H^{cu}(W^c(x), W^c(y)) < \epsilon$ if and only if there are ϵ -neighborhoods

$$U_\epsilon := \bigcup_{w \in W^c(x)} \{v \in W^{cu}(x) \mid d_{cu}(v, w) < \epsilon\}$$

of $W^c(x)$ and V_ϵ of $W^c(y)$ such that $W^c(y) \subset U_\epsilon$ and $W^c(x) \subset V_\epsilon$. We denote with $W_r^{cu}(y)$ the set $\{z \in W^{cu}(y) \mid d_H^{cu}(W^c(z), W^c(y)) < r\}$. It is open in $W^{cu}(y)$ by the definition of d_H^{cu} and \mathcal{W}^c -saturated. We call a \mathcal{W}^c -saturated set $A \subset W^{cu}(x)$ open if for $y \in A$ there exists $\delta > 0$ such that $W^c(z) \subset A$ if $d_H^{cu}(W^c(z), W^c(y)) < \delta$ and $z \in W^{cu}(x)$. From now on, we consider the topology

$$\mathcal{T}_x^{cu} := \{A \subset W^{cu}(x) \mid \text{Sat } A = A \text{ and } A \text{ open}\}$$

of \mathcal{W}^c -saturated subsets contained in a single center-unstable leaf $W^{cu}(x)$ for some $x \in M$. Since \mathcal{W}^c is a compact foliation with finite holonomy any saturate $\text{Sat } A = \bigcup_{x \in A} W^c(x)$ of a compact set $A \subset M$ is also compact in M . At the same time, every saturate of an open set is also open in M . If we restrict the foliation \mathcal{W}^c to a center-unstable leaf $W^{cu}(x)$ it is still a compact foliation with finite holonomy. Analogously, the saturate $\text{Sat } A$ of a compact set $A \subset W^{cu}(x)$ is also compact in $W^{cu}(x)$ with respect to the leaf topology of $W^{cu}(x)$.

As f is centrally transitive any center-unstable and center-stable leaf is dense in M as we proved in Lemma 1.44. So, we can prove the following:

Lemma 2.37. *For any $x, y \in M$ and for any $r > 0$ the intersection $W^s(x) \cap W_r^{cu}(y)$ is non-empty.*

Proof. Since the center-unstable and the center-stable leaf are dense it holds for any $x, y \in M$ and for any $r > 0$ that $W^{cs}(x) \cap W_r^{cu}(y) \neq \emptyset$. So there exists $W^c(z) \subset W^{cs}(x) \cap W_r^{cu}(y)$. Then there is a $\tilde{z} \in W^s(x) \cap W^c(z)$ and we can conclude that the intersection $W^s(x) \cap W_r^{cu}(y)$ is non-empty. \square

Let $x, y \in M$ be two arbitrary points. Given $\epsilon > 0$, we call two non-empty sets $A_1 \in \mathcal{T}_x^{cu}, A_2 \in \mathcal{T}_y^{cu}$ ϵ -equivalent if for every $x \in A_1$ and $y \in A_2$ there exist $\delta_1 > 0$ and $\delta_2 > 0$ and a well-defined local holonomy homeomorphism along stable leaves $h^s : W_{\delta_1}^{cu}(x) \rightarrow W_{\delta_2}^{cu}(y)$ defined by $z \mapsto W^s(z) \cap W_{\delta_2}^{cu}(y)$ such that h^s maps A_1 homeomorphically onto A_2 and the distance $d_s(z, h^s(z))$ inside the stable leaf $W^s(z)$ is $< \epsilon$ for all $z \in A_1$.

Remark 2.38. *In the following we consider stable holonomies defined on W^c -saturated sets. Usually, a local holonomy homeomorphism is defined on small disks transversal to W^s , but because of the dynamical coherence we can extend the definition to the W^c -saturate of such a small disk: For any $z \in W_{loc}^{cu}(x)$ with $W^s(z) \cap W_{loc}^{cu}(y) = w$ it holds that for any $\tilde{z} \in W^c(z)$ it is $W^s(\tilde{z}) \cap W_{loc}^{cu}(y) \neq \emptyset$ because $W^c(w) \subset W^{cs}(z)$.*

With this definition, Lemma 2.37 implies the following:

Corollary 2.39. *Let $A \in \mathcal{T}_z^{cu}$ for some $z \in M$. Then there exists $r(A) > 0$ and $\epsilon(A) > 0$ such that for all $x \in M$ the open ball $W_{r(A)}^{cu}(x)$ is $\epsilon(A)$ -equivalent to a subset of A .*

Proof. For any point $x \in M$ there are positive constants $\epsilon(x)$ and $r(x)$ and a neighborhood $U(x)$ such that for any $y \in U(x)$ the local center-unstable leaf $W_{r(x)}^{cu}(y)$ is $\epsilon(x)$ -equivalent to some subset of A . We can now consider a finite covering by sets $U(x_1), \dots, U(x_k)$ with $x_1, \dots, x_k \in M$. Let $\epsilon := \max_{1 \leq i \leq k} \epsilon(x_i)$ and $r := \max_{1 \leq i \leq k} r(x_i)$. Then these are the constants we search. \square

Then the following Lemma holds:

Lemma 2.40. *Let $f : M \rightarrow M$ be a centrally transitive partially hyperbolic C^2 -diffeomorphism with a compact center foliation with trivial holonomy. Let $A \in \mathcal{T}_z^{cu}$ for some $z \in M$ and $r := r(A) > 0$ as in Corollary 2.39. Then there exists a constant $c(A) > 0$ such that*

$$\frac{\lambda_{cu}(f^n(W_r^{cu}(x)))}{\lambda_{cu}(f^n A)} < c(A)$$

for all $n \geq 0$ and $x \in M$.

Proof. To show this Lemma the assumption of higher differentiability of f is necessary, otherwise this Lemma is not true. So, here we need that f is at least C^2 : It is shown by Brin and Pesin in [BP74] and Pugh and Shub in [PS96] that for $x, y \in M$ sufficiently close the holonomy map $h^s : W_{loc}^{cu}(x) \rightarrow W_{loc}^{cu}(y)$ along stable manifolds is absolutely continuous with respect to the measures $\lambda_{cu(x)}$ and $\lambda_{cu(y)}$ and the Jacobian of h^s is bounded from above and away from zero if f is a partially hyperbolic C^2 -diffeomorphism on a smooth manifold. Hence, if we assume $n \geq N$ sufficiently large such that the set $f^n W_r^{cu}(x)$ is sufficiently close to $f^n A$, i.e. it is $\lambda^n \epsilon$ -equivalent by a holonomy h^s to some subset $C \subset f^n A$ where $\lambda < 1$. Then by the absolute continuity we get $\lambda_{cu}(f^n W_r^{cu}(x)) = \text{Jac}(h^s) \lambda_{cu}(C) \leq \text{Jac}(h^s) \lambda_{cu}(f^n A)$. As the Jacobian of h^s is bounded there exists a constant $c(A)$ such that $\lambda_{cu}(f^n W_r^{cu}(x)) < c(A) \lambda_{cu}(f^n A)$. For $n = 0, \dots, N - 1$ the boundedness of the fraction follows from the fact that we have a finite family of continuous holonomy maps establishing the ϵ -equivalence between $f^n W_r^{cu}(x)$ and some subset $C \subset f^n(A)$, for every n there exists a bound and because it is a finite family there exists a common bound for the fraction. \square

Following from now on our road map, we start with the definition of a set C of certain functions whose support is contained in a center-unstable leaf. From now we fix an open set $A \in \mathcal{T}_z^{cu}$ for some $z \in M$ with compact closure in $W^{cu}(z)$. We define the set

$$C := \{ \phi : M \rightarrow \mathbb{R} \mid \exists x \in M : \text{supp}(\phi) \subset W^{cu}(x), \phi|_{\text{supp}(\phi)} \text{ is continuous,} \\ \phi \equiv \text{const along center leaves.} \}$$

of all continuous functions whose support is wholly contained inside one center-unstable leaf and which are constant along center leaves, so their supports are always W^c -saturated sets. Up to now, this set is neither a vector space nor a topological space, and the addition of two functions $\phi, \psi \in C$ is only defined if there exists $x \in M$ such that $\text{supp}(\phi), \text{supp}(\psi) \subset W^{cu}(x)$. This will be repaired in the continuation of the construction.

We continue with the definition of an appropriate topological vector space C^* : We consider the space C^{**} of all maps $l : C \rightarrow \mathbb{R}$. It is closed under addition and scalar multiplication as $a(l_1 + l_2)$ for any $l_1, l_2 \in C^{**}$ and $a \in \mathbb{R}$ is defined by $a(l_1 + l_2)(\phi) = al_1(\phi) + al_2(\phi)$ for all $\phi \in C$. Clearly, the inverse element $-l$ of a map l is just defined by $-l(\phi) \in \mathbb{R}$ for every $\phi \in C$. We show that the space C^{**} is naturally isomorphic to $\prod_{\phi \in C} \mathbb{R}_\phi$ and by this identification we obtain a well-defined topology on C^{**} and we can consider C^{**} as a topological vector space.

Lemma 2.41. *The set $C^{**} := \{l : C \rightarrow \mathbb{R} \mid l \text{ map}\}$ is isomorphic to $\prod_{\phi \in C} \mathbb{R}_\phi$ where $\mathbb{R}_\phi = \mathbb{R}$.*

Proof. We define the isomorphism $\Psi : C^{**} \rightarrow \prod_{\phi \in C} \mathbb{R}_\phi$ by $l \mapsto \prod_{\phi \in C} l(\phi)$. Then Ψ is injective because if $\Psi(l_1) = \Psi(l_2)$ then the maps l_1 and l_2 coincide in all their images and so they are identical, i.e. $l_1 \equiv l_2$. Further, the map Ψ is surjective: For any sequence $\{x_\phi\}_{\phi \in C}$ with $x_\phi \in \mathbb{R}_\phi$ we can define a map $l \in C^{**}$ by $l(\phi) = x_\phi$. It is a homomorphism because it holds for any $\phi \in C$ and $a \in \mathbb{R}$ that $\Psi(a(l_1 + l_2)(\phi)) = a(l_1 + l_2)(\phi) \in \mathbb{R}_\phi$ and $a(l_1 + l_2)(\phi) = al_1(\phi) + al_2(\phi) = a\Psi(l_1(\phi)) + a\Psi(l_2(\phi))$ because of the additive structure of \mathbb{R} . \square

We will thus use the product topology of $\prod_{\phi \in C} \mathbb{R}_\phi$ on C^{**} which coincides with the topology by pointwise convergence (it coincides with the weak*-topology in the case of a linear space as C^{**}). The basis of the product topology consists of $\prod I_\phi$ where $I_\phi \subset \mathbb{R}_\phi$ is an open interval for finitely many $\phi \in C$ and $I_\phi = \mathbb{R}_\phi$ otherwise.

Now, we consider the subset

$$C^* := \{l \in C^{**} \mid l \text{ is linear}\}$$

of all linear functionals $l : C \rightarrow \mathbb{R}$ where we call a functional l *linear* if it fulfills $l(a\phi + b\psi) = al(\phi) + bl(\psi)$ whenever $a\phi + b\psi \in C$ for $\phi, \psi \in C$ and $a, b \in \mathbb{R}$. It is easily calculated that the subset C^* is closed under scalar multiplication and vector addition and thus it is a subspace of the topological vector space C^{**} . We show the following essential property:

Lemma 2.42. *The space C^* is locally convex.*

Proof. As explained above C^* is closed under the scalar multiplication and vector addition defined in C^{**} and therefore it is a subspace of the topological vector space C^{**} . The local convexity is directly implied by the product topology and the local convexity of \mathbb{R} . Recall that a vector space is locally convex if it has a family of seminorms. We get in a natural way a family $\{p_\phi\}_{\phi \in C}$ of seminorms by defining for every $\phi \in C$ a seminorm $p_\phi : C^* \rightarrow \mathbb{R}$ by $l \mapsto |l(\phi)|$. The natural topology induced by this family of seminorms coincides with the product topology. \square

Remark 2.43. *The locally convex topological vector space C^* inherits the completeness of \mathbb{R} . Let $l_n \in C^*$ for $n \geq 0$ be a Cauchy sequence, i.e. for every neighborhood $\prod_\phi I_\phi$ of $0 \in \prod_{\phi \in C} \mathbb{R}_\phi$ there exists $N \in \mathbb{N}$ such that for all $n, m \geq N$ it is $l_n - l_m \in \prod_\phi I_\phi$. As \mathbb{R} is complete, $(l_n - l_m)(\phi)$ converge to zero and so the Cauchy sequence l_n converge in C^* .*

Recall what we are going to do: We want to construct a measure as dual to a linear functional \tilde{L} . This functional \tilde{L} is the fixed point of some map

\tilde{f} on the dual space C^* . To obtain a fixed point we would like to apply the Fixed Point Theorem by Tychonoff. This states that any continuous map of a compact convex subset of a locally convex topological vector space has a fixed point. Therefore we have to construct a compact subspace \overline{C}_2^* of the locally convex topological vector space C^* . For this purpose, we fix a positive function $\phi_0 \in C$ with $\phi_0 > \chi_A$ and define the subsets

$$\begin{aligned} C_1^* &:= \left\{ L \in C^* \mid L = \sum_{i=1}^m c_i L_{n_i}, c_i \geq 0 \right\} \\ C_2^* &:= \{ L \in C_1^* \mid L(\phi_0) = 1 \}, \quad \text{where} \\ L_n(\phi) &:= \int \phi \circ f^{-n} d\lambda_{cu} \text{ for } \phi \in C \text{ and } n \in \mathbb{N}. \end{aligned}$$

The subspace C_2^* consists of linear combinations of $\frac{L_n}{L_n(\phi_0)} =: \tilde{L}_n$ for $n \geq 0$. Hence, the subspace C_2^* is the convex hull of the set $\bigcup_{n \geq 0} \tilde{L}_n$. We show that \overline{C}_2^* is compact.

Lemma 2.44. *The space \overline{C}_2^* is a compact subspace of C^* .*

Proof. We remark that the closed convex hull of a compact subset of a complete locally convex topological vector space is compact. Hence, it is enough to show that the set $\bigcup_{n \geq 0} \tilde{L}_n$ is compact. By the natural embedding of $\overline{C}_2^* \subset C^*$ into $\prod_{\phi \in C} \mathbb{R}_\phi$ the set $\bigcup_{n \geq 0} \tilde{L}_n$ of \tilde{L}_n can be identified by $\tilde{L}_n \mapsto \prod_{\phi \in C} \tilde{L}_n(\phi)$ with a subset of a product $\prod_{\phi \in C} \left[\inf_{n \geq 0} \tilde{L}_n(\phi), \sup_{n \geq 0} \tilde{L}_n(\phi) \right]$ of intervals. If for every $\phi \in C$ the respective interval is compact, we can conclude with the theorem of Tychonoff that any product of compact spaces is compact and hence, the set $\bigcup_{n \geq 0} \tilde{L}_n$ is compact. To do this we just have to show that for every $\phi \in C$ the set of linear functionals $\tilde{L}_n : C \rightarrow \mathbb{R}$ with $\tilde{L}_n = \frac{L_n}{L_n(\phi_0)}$ for $n \geq 0$ are bounded from above and from below.

Lemma 2.45. *For any positive function $\phi \in C$ and any compact W^c -saturated set $K \subset W^{cu}(z)$ for some $z \in M$ there exists a constant $c(K, \phi) > 0$ such that if ψ is a bounded W^{cu} -measurable function with $\text{supp}(\psi) \subset K$, then it holds for any $n \geq 0$*

$$\frac{L_n(\psi)}{L_n(\phi)} < c(K, \phi) \|\psi\|,$$

where $\|\psi\|$ is the essential supremum norm of ψ .

Proof. We define the set $B := \{x \in M \mid \phi(x) > \epsilon\}$. Then we can cover K by N balls $W_{r(B)}^{cu}(x_i)$ with $x_1, \dots, x_N \in M$. It follows

$$\begin{aligned} \int \psi \circ f^{-n} d\lambda_{cu} &\leq \lambda_{cu}(f^n K) \|\psi\| \\ &\leq \sum_{i=1}^N \lambda_{cu}(f^n(W_{r(B)}^{cu}(x_i))) \|\psi\| \text{ by Lemma 2.40} \\ &< Nc(B)\lambda_{cu}(f^n B) \|\psi\| \\ &< \frac{Nc(B)}{\epsilon} \int \phi \circ f^{-n} d\lambda_{cu} \|\psi\|. \end{aligned}$$

So by defining $c(K, \phi) := \frac{Nc(B)}{\epsilon}$ we prove the theorem. \square

It follows from Lemma 2.45 above that $\tilde{L}_n(\phi) < c(\text{supp}(\phi), \phi_0) \|\phi\| =: c_1(\phi)$ and, if $\phi \in C$ is a positive function by interchanging the roles of ϕ and ϕ_0 we get that $\tilde{L}_n(\phi) > \frac{1}{c(\text{supp}(\phi_0), \phi) \|\phi_0\|} =: c_2(\phi)$. So, this implies that $\bigcup_{n \geq 0} \tilde{L}_n$ is isomorphic to a subset of $\prod_{\phi \in C} [c_2(\phi), c_1(\phi)]$ which is a compact set with Tychonoff. The space \overline{C}_2^* is the closure of the convex hull of the set of \tilde{L}_n and therefore it is compact as well. \square

Recall that we construct the measure as dual to a certain functional $\tilde{L} \in \overline{C}_2^*$ which is the fixed point of a certain continuous map \tilde{f} . Hence, we go on with defining \tilde{f} and establishing its continuity. We define a map $\hat{f} : C_1^* \rightarrow C_1^*$ by $\hat{f}(L_n)(\phi) = L_n(\phi \circ f^{-1})$ and a map

$$\begin{aligned} \tilde{f} : \overline{C}_2^* &\rightarrow \overline{C}_2^* \\ \tilde{f}(\tilde{L}_n)(\phi) &= \frac{\hat{f}(L_n)(\phi)}{\hat{f}(L_n)(\phi_0)} = \frac{L_n(\phi \circ f^{-1})}{L_n(\phi_0 \circ f^{-1})} \text{ for } \phi \in C. \end{aligned}$$

At the moment, C is only a set of functions without further structure. In order to show the continuity of this map \tilde{f} we need a concept of ϵ -closeness between functions in C . For this definition we have to introduce two auxiliary functions and the following concept of ϵ -equivalence between two functions in C . Given $\epsilon > 0$, we call two functions $\phi_1, \phi_2 \in C$ ϵ -equivalent if their supports $\text{supp}(\phi_1), \text{supp}(\phi_2)$ are ϵ -equivalent by a well-defined holonomy h^s along stable leaves and if $\phi_2 \circ h^s = \phi_1$.

Now, we define the first auxiliary function. Let $x \in M$ and define the function

$$\phi_x(y) := \frac{1}{\left(1 + \lambda_{cu}\left(W_{r(y)}^{cu}(x)\right)\right)^2}, \quad r(y) := d_H^{cu}(W^c(x), W^c(y)),$$

2.5. Codimension-(1+k) center Foliation

if $y \in W^{cu}(x)$ and $\phi_x(y) = 0$ otherwise. The function ϕ_x is maximal for all $y \in W^c(x)$ and decreases monotonically with increasing radius. It is constant along center leaves. We show that its integral on a center-unstable leaf is bounded which is necessary to obtain a certain bound below.

Lemma 2.46.

$$\int \phi_x(y) d\lambda_{cu} < 2.$$

Proof. We define $U_{i,x} := \left\{ y \in W^{cu} \mid i \leq \lambda_{cu} \left(W_{r(y)}^{cu}(x) \right) < i + 1 \right\}$. It is $\lambda_{cu}(U_{i,x}) \leq 1$. Then it is

$$\int \phi_x(y) d\lambda_{cu} = \sum_{i=0}^{\infty} \int_{U_{i,x}} \phi_x(y) d\lambda_{cu} \leq \sum_{i=0}^{\infty} \frac{1}{(1+i)^2} < 2.$$

□

For any set $A \in \mathcal{T}_z^{cu}$ for some $z \in M$ with compact closure in $W^{cu}(z)$ we define the following second auxiliary function

$$\tilde{\phi}_{x,A}(y) := \int K_{y,A}(z) \phi_x(z) d\lambda_{cu}(z),$$

where $K_{y,A}(z) = 1$ for $z \in \overline{W_{r(A)}^{cu}(y)}$ and $K_{y,A}(z) = 0$ otherwise. The function $\tilde{\phi}_{x,A}$ is constant along center leaves. With the help of this auxiliary function $\tilde{\phi}_{x,A}$ we introduce now the concept of ϵ -closeness: Given $\epsilon > 0$, we call $\phi_1, \phi_2 \in C$ ϵ -close if there exists $\tilde{\phi}_1, \tilde{\phi}_2 \in C$ and $x_1, x_2 \in M$ such that $\tilde{\phi}_1, \tilde{\phi}_2$ are ϵ -equivalent and $|\phi_i(z) - \tilde{\phi}_i(z)| < \epsilon \tilde{\phi}_{x_i,A}(z)$ for all $z \in M$ and $i = 1, 2$.

The concept of ϵ -closeness provides a topology on the set C . Finally, we proceed with the following Lemma that \tilde{f} is continuous.

Lemma 2.47. *The map $\tilde{f} : \overline{C_2^*} \rightarrow \overline{C_2^*}$ as defined above is continuous.*

By the weak*-topology and the definition of \tilde{f} , the map \tilde{f} is continuous if \tilde{L}_n is continuous. This is shown in the following Lemma.

Lemma 2.48. *For any $\phi \in C$ and any $\delta > 0$ there exists an $\epsilon > 0$ such that if $\psi \in C$ is ϵ -close to ϕ , then we have*

$$\left| \tilde{L}_n(\phi) - \tilde{L}_n(\psi) \right| < \delta.$$

Proof. By definition we have

$$\begin{aligned}
 |L_n(\phi) - L_n(\psi)| &= \left| \int \phi \circ f^{-n} d\lambda_{cu} - \int \psi \circ f^{-n} d\lambda_{cu} \right| \\
 &\leq \left| \int \phi \circ f^{-n} - \int \tilde{\phi} \circ f^{-n} d\lambda_{cu} \right| + \left| \int \tilde{\psi} \circ f^{-n} - \int \psi \circ f^{-n} d\lambda_{cu} \right| \\
 &\quad + \left| \int \tilde{\phi} \circ f^{-n} - \int \tilde{\psi} \circ f^{-n} d\lambda_{cu} \right| \\
 &\leq \epsilon \int \tilde{\phi}_{x_1, A} \circ f^{-n} d\lambda_{cu} + \epsilon \int \tilde{\phi}_{x_2, A} \circ f^{-n} d\lambda_{cu} \quad \text{by definition of } \epsilon\text{-close} \\
 &\quad + \left| \int \tilde{\phi} \circ f^{-n} - \int \tilde{\psi} \circ f^{-n} d\lambda_{cu} \right|
 \end{aligned}$$

To obtain certain bounds for the above we need the two following auxiliary Lemmata:

Lemma 2.49. *For any $y \in M$ and $n \geq 0$ it holds*

$$\int \tilde{\phi}_{x, A}(f^{-n}y) d\lambda_{cu} < 2c(A)\lambda_{cu}(f^n A),$$

where $c(A)$ is the constant of Lemma 2.40.

Proof. It is $K_{y, A}(z) = K_{z, A}(y)$. Using this, the Fubini Theorem, Lemma 2.40 and Lemma 2.46 yields

$$\begin{aligned}
 &\int \tilde{\phi}_{x, A}(f^{-n}y) d\lambda_{cu} \\
 &= \int \int K_{f^{-n}y, A}(z) \phi_x(z) d\lambda_{cu}(z) d\lambda_{cu}(y) \\
 &= \int \int K_{z, A}(f^{-n}y) d\lambda_{cu}(y) \phi_x(z) d\lambda_{cu}(z) \\
 &= \int \lambda_{cu}(f^n W_{r(A)}^{cu}(z)) \phi_x(z) d\lambda_{cu}(z) < 2c(A)\lambda_{cu}(f^n A).
 \end{aligned}$$

□

Lemma 2.50. *For any $\delta > 0$ there is $\epsilon > 0$ such that if $\phi_1, \phi_2 \in C$ are ϵ -equivalent then it holds*

$$\left| \int \phi_1 d\lambda_{cu} - \int \phi_2 d\lambda_{cu} \right| < \delta \int |\phi_1| d\lambda_{cu}.$$

2.5. Codimension-(1+k) center Foliation

Proof. There are step functions $\underline{\xi}$ and $\bar{\xi}$ representing upper and lower Riemann sums for $\int \phi_1 d\lambda_{cu}$ that are accurate to within $\frac{\delta}{2} \int |\phi_1| d\lambda_{cu}$. It suffices to show the result for $\underline{\xi}$ and $\bar{\xi}$ and by considering the corresponding ϵ -equivalent step functions for ϕ_2 . As their integrals are just finite sums of ϵ -equivalent sets we only have to show that for a given set $B \subset W^{cu}(z)$ for some $z \in M$ and $\alpha > 0$ there exists η such that for any η -equivalent set B' it holds $|\lambda_{cu}(B) - \lambda_{cu}(B')| < \alpha$. But for $\eta \rightarrow 0$ the holonomy maps between B and B' converge to isometries so the statement follows. \square

Now, applying Lemma 2.49 and dividing by $\int \phi_0 \circ f^{-n} d\lambda_{cu}$ we get

$$\left| \tilde{L}_n(\phi) - \tilde{L}_n(\psi) \right| \leq \epsilon 4c(A) + \frac{\delta}{2c(\text{supp}(\tilde{\phi}), \phi_0)} \int |\tilde{\phi}| d\lambda_{cu}$$

for sufficiently small ϵ due to Lemma 2.50. Remember that $\phi_0 > \chi_A$. It follows

$$\leq \epsilon 4c(A) + \frac{\delta}{2} \quad \text{due to Lemma 2.45.}$$

So by choosing $\epsilon < \frac{\delta}{8c(A)}$ we prove the statement. \square

In the above we have just established the continuity of $\tilde{f} : \overline{C}_2^* \rightarrow \overline{C}_2^*$. In Lemma 2.44 we showed that \overline{C}_2^* is a compact convex subspace of C^* . Hence, we can apply the Fixed Point Theorem by Tychonoff and conclude that there exists $\tilde{L} \in \overline{C}_2^*$ such that

$$\tilde{f}\tilde{L} = \tilde{L}.$$

We showed in Lemma 2.48 that any $L \in C_2^*$ is continuous, and therefore $\tilde{L} \in \overline{C}_2^*$ is continuous.

The last step to construct the measure μ_A^{cu} is to apply the Riesz Representation Theorem. For this we consider the subspace

$$C_c(U) := \{ \phi \in C \mid \text{supp}(\phi) \subset \overline{U} \}$$

where $U \in \mathcal{T}_z^{cu}$ is a fixed open set inside $W^{cu}(z)$ for some $z \in M$ with compact closure endowed with the supremum norm and the space $C(\overline{U})$ of functions $\phi \in C$ which are continuous on \overline{U} with supremum norm. By Lemma 2.48 it is shown that $\tilde{L}|_{C_c(U)}$ is a continuous functional and by the Hahn-Banach Theorem $L|_{C_c(U)}$ extends to a continuous functional \tilde{L} on $C(\overline{U})$. Then there exists by the Riesz Representation Theorem a unique regular Borel measure μ^{cu} on U such that

$$\tilde{L}(\phi) = \int \phi d\mu_{\overline{U}}^{cu}(x)$$

for any $\phi \in C_c(U)$. The measure μ_U^{cu} might not be unique on the boundary $\bar{U} \setminus U$. So we consider two open sets $U_1 \subset U_2 \subset W^{cu}$ with compact closure. Then there exists a non-decreasing sequence of non-negative functions ϕ_i such that $\phi_i \in C_c(U_2)$ and ϕ_i converges pointwise to χ_{U_1} . Then it is implied that

$$\mu_{U_2}^{cu}(U_1) = \tilde{L}|_{U_2}(\chi_{U_1}) = \lim_{i \rightarrow \infty} \tilde{L}(\phi_i).$$

Consequently, for any open set $U \subset W^{cu}$ with compact closure there exists a unique measure μ^{cu} such that $\mu^{cu}(U_0) = \mu_U^{cu}(U_0)$ for any $U_0 \subset U$.

The measure μ^{cu} extends to a measure on the σ -Borel algebra generated by all open sets $A \in \mathcal{T}_z^{cu}$ for every $z \in M$ with compact closure, and it is positive on non-empty open sets because \tilde{L} is bounded from below for any positive function $\phi \in C$, hence, in particular for χ_A where $A \in \mathcal{T}_z^{cu}$ is a non-empty open set.

In the following Lemmata we establish the respective properties of our measure: We start with showing the holonomy-invariance of the measure:

Lemma 2.51 (Holonomy-invariant). *Let $x, y \in M$ be arbitrary points. For any ϵ -equivalent sets $A_1 \in \mathcal{T}_x^{cu}, A_2 \in \mathcal{T}_y^{cu}$ it holds*

$$\mu^{cu}(A_1) = \mu^{cu}(A_2).$$

Proof. Assume that A_1 and A_2 are non-empty. Then Lemma 2.50 implies that

$$\lim_{n \rightarrow \infty} \frac{\lambda_{cu}(f^n A_1)}{\lambda_{cu}(f^n A_2)} = \lim_{n \rightarrow \infty} \frac{L_n(\chi_{A_1})}{L_n(\chi_{A_2})} = 1.$$

It holds the same for any finite linear combination of L_n and hence for the limit \tilde{L} of finite linear combinations. So we get

$$\lim_{n \rightarrow \infty} \frac{\tilde{f}^n \tilde{L}(\chi_{A_1})}{\tilde{f}^n \tilde{L}(\chi_{A_2})} = 1 = \frac{\tilde{L}(\chi_{A_1})}{\tilde{L}(\chi_{A_2})}.$$

□

Lemma 2.52 (Expanding). *There exists $d > 1$ such that $\mu^{cu}(f^n U) = d^n \mu^{cu}(U)$ for any $U \in \mathcal{T}^{cu}$ with compact closure.*

Proof. It is $\tilde{L}(\chi_U) = \tilde{f}^n \tilde{L}(\chi_U)$ and by definition of \tilde{f} this yields $\tilde{L}(\chi_U \circ f^{-n}) = \tilde{L}(\phi_0 \circ f^{-n}) \tilde{L}(\chi_U)$. So we set $d := \tilde{L}(\phi_0 \circ f^{-1})$ and by induction we can show that $\mu^{cu}(f^n U) = \tilde{L}(\chi_U \circ f^{-n}) = d^n \tilde{L}(\chi_U) = d^n \mu^{cu}(U)$. As the support of ϕ_0 is a W^c -saturated set contained in a center-unstable leaf it is expanded by f , so $d > 1$ is implied. □

□

Corollary 2.53. *Let $z \in M$ be an arbitrary point. It holds that $\mu^{cu}(A) = \infty$ if and only if $A \subset W^{cu}(z)$ is a unbounded \mathcal{W}^c -saturated set.*

Proof. If $A \subset W^{cu}(z)$ for some $z \in M$ is an open set with compact closure then $\mu^{cu}(A)$ is finite by construction of the measure. Now consider an unbounded set $A \subset W^{cu}(z)$. Then there exists a sequence (A_n) of open sets $A_n \in \mathcal{T}_z^{cu}$ with compact closure such that $A_n \subset A_{n+1} \subset A$ for all $n \in \mathbb{N}$ and $A_{n+1} \setminus A_n$ has positive measure. Hence, we get an strictly increasing sequence $\mu^{cu}(A_n)$ of real numbers which diverges. \square

Because of the way we constructed μ^{cu} we can easily project it to the leaf space M/\mathcal{W}^c and we define $\mu^u(A) := \mu^{cu}(\pi^{-1}(A))$ where $A \subset W^u(z)$ for some $z \in M$ open with compact closure inside $W^u(z)$ and $\mathcal{W}^u = \pi\mathcal{W}^{cu}$ the topological one-dimensional unstable foliation in the leaf space.

Construction of the homeomorphism between the leaf space and the q -torus. To adopt Hiraide's proof we have to establish Franks' theorem for our case in the following way where M denotes a topological manifold from now on and f the homeomorphism on M induced by a partially hyperbolic diffeomorphism \tilde{f} :

Theorem 2.54. *Let $\tilde{f} : \tilde{M} \rightarrow \tilde{M}$ be a partially hyperbolic C^∞ -diffeomorphism with a compact center foliation with finite holonomy. Assume that E^u is one-dimensional and oriented. Then $f : M \rightarrow M$ on the leaf space M is topologically conjugate to a hyperbolic toral automorphism and M is homeomorphic to a q -torus where q denotes the codimension of the center foliation \mathcal{W}^c .*

Remark 2.55. *We know by Theorem C(1),(2) that the center foliation has only trivial holonomy and that therefore the leaf space M is a compact topological manifold. The center-unstable and center-stable foliations in \tilde{M} projects to transverse stable and unstable topological foliations in M . We recall that the map f is shown to be expansive and transitive on the leaf space M and it has the pseudo-orbit tracing property.*

The projected measure μ^u on the one-dimensional unstable foliation is positive on non-empty open sets and non-atomic. Hence, it is the (smooth) Lebesgue measure (up to multiplication by a constant).

The proof is divided into four main steps:

1. We show in Lemma 2.56 below that there exists a universal cover \overline{M} of M which is homeomorphic to \mathbb{R}^q .

2. Lemma 2.57 states that the fundamental group $\pi_1(M)$ is isomorphic to \mathbb{Z}^m for some $m \in \mathbb{N}$.
3. The lifted map F of f on the universal cover \overline{M} is topologically conjugate to a linear hyperbolic map $A \in \text{GL}(m, \mathbb{Z})$ as it is shown in Lemma 2.59.
4. Finally, we can conclude that this topological conjugacy descends to a topological conjugacy between f and the hyperbolic toral automorphism ϕ_A induced by A establishing a homeomorphism between M and $\mathbb{T}^q = \mathbb{R}^q/\mathbb{Z}^q$ as well.

Proof. We have a uniform local product structure on M so we have a local holonomy homeomorphism $h^u : I \rightarrow J$ where $I \subset W^u(x), J \subset W^u(y)$ are open arcs inside a product neighborhood U defined by $z \in I \mapsto W^s(z) \cap J$. We call any finite composition of local holonomy homeomorphisms a holonomy homeomorphism.

We may assume that $f : M \rightarrow M$ has a fixed point p : In any case it has a periodic point p such that $f^n(p) = p$, so we could prove the statement for $g := f^n$. Then f^n is conjugate to a hyperbolic toral automorphism and this implies that f is conjugate to a hyperbolic toral automorphism.

Therefore, let $p \in M$ be a fixed point for f . We have $\dim \mathcal{W}^u = 1$ and - as E^u in $\pi^{-1}M$ is oriented - we may fix a direction on arcs of \mathcal{W}^u . We will construct the simply connected cover \overline{M} for M by $W^u(p) \times W^s(p)$ and show that it is homeomorphic to \mathbb{R}^q . Let $(x, y) \in W^u(p) \times W^s(p)$. For any $x \in W^u(p)$ we denote with $[p, x]$ the arc inside $W^u(p)$ with end points p and x and for any $z \in W^u(y)$ with $[y, z]$ the arc inside $W^u(y)$ with end points y and z .

Lemma 2.56. *The manifold M has a universal cover*

$$\pi_p : W^u(p) \times W^s(p) \rightarrow M$$

where $\pi_p(x, y) = z$ such that $\mu^u([p, x]) = \mu^u([y, z])$ and the orientation from p to x is consistent with the orientation from y to z . Further, $W^u(p) \times W^s(p)$ is homeomorphic to \mathbb{R}^q where $q = \text{codim } \mathcal{W}^c$.

Proof. The most important step in the construction of the universal cover is to show that the intersection of $W^u(x) \cap W^s(y)$ for any points $x, y \in M$ contains exactly one point. This will be shown with the help of the family of measures μ^u on the unstable leaves. The transverse invariant measure is invariant under a holonomy homeomorphism h^u . Then there exists a point $z \in W^u(y)$ such that

$$\mu^u([p, x]) = \mu^u([y, z])$$

2.5. Codimension-(1+k) center Foliation

and the orientation from p to x is consistent with the orientation from y to z . This point is unique as the measure μ^u is positive on any non-empty open interval, accordingly, if there would be two points $z_1 < z_2$ in $W^u(y)$ it would follow $\mu^u([y, z_2] \setminus [y, z_1]) = \mu^u((z_1, z_2]) = 0$ and hence, $z_1 = z_2$. Further, every unbounded arc I has the measure $\mu^u(I) = \infty$ as we showed in Corollary 2.53.

Therefore the map $\pi_p : W^u(p) \times W^s(p) \rightarrow M$ is well-defined by $(x, y) \mapsto \pi_p(x, y) = z$ such that $\mu([p, x]) = \mu([y, \pi_p(x, y)])$. We showed in Lemma 2.39 that for any $y \in M$ a open arc $(y, z) \subset W^u(x)$ of positive length is ϵ -equivalent to some subset of $W^u(p)$. This means, there exists a holonomy homeomorphism $h^u : (p, x) \mapsto (y, z)$ for some suitable $x \in W^u(p)$. This shows the surjectivity of the map π_p . The point $\pi_p((x, y))$ is contained in a product neighborhood and as μ^u is holonomy-invariant we can conclude that $\pi_p(x, y) \in W^s(x) \cap W^u(y)$ and π_p is continuous (as the canonical coordinates are continuous). If $N \subset M$ is a product neighborhood for z then it is easily seen that $\pi_p^{-1}(N)$ is a union of disjoint sets homeomorphic to N . Further, $W^u(p) \times W^s(p)$ is homeomorphic to $\mathbb{R} \times \mathbb{R}^{q-1}$ as they are stable and unstable foliations by Lemma 1.46, and so the cover is simply connected. It can be concluded that the map $\pi_p : W^u(p) \times W^s(p) \rightarrow M$ is a universal cover for M which will be denoted by \bar{M} in the following. \square

Firstly, we remark that - applying Theorem 1 in [DH72] - we can lift the metric d of M to a metric ρ of \bar{M} and we can find a number $r_0 > 0$ such that

1. If $\bar{x}, \bar{y} \in \bar{M}$ and $\rho(\bar{x}, \bar{y}) \leq 2r_0$ then $d(\pi_p(\bar{x}), \pi_p(\bar{y})) = \rho(\bar{x}, \bar{y})$.
2. If $\bar{x} \in \bar{M}$, $y \in M$ and $d(\pi_p(\bar{x}), y) \leq 2r_0$ then there is a unique $\bar{y} \in \bar{M}$ such that $\bar{y} \in \pi_p^{-1}M$ and $\rho(\bar{x}, \bar{y}) = d(\pi_p(\bar{x}), y)$.
3. All covering transformations are C^0 -isometries.
4. ρ is a complete metric.

For simplicity we will denote ρ with d again.

Lemma 2.57. *The fundamental group $\pi_1(M)$ is isomorphic to \mathbb{Z}^m for some $m \in \mathbb{N}$.*

Proof. The fundamental group $\pi_1(m)$ is isomorphic to the group of all covering transformations $\alpha : \bar{M} \rightarrow \bar{M}$, i.e. $\pi_p \circ \alpha = \pi_p$. Therefore we consider both as equal in the following. For $x \in W^u(p)$ we denote with $\tilde{\alpha}(x) \in W^u(p)$ the first coordinate of $\alpha((x, y)) \in \bar{M}$ for any $y \in W^s(p)$. It follows that $\mu^u(I) = \mu^u(\tilde{\alpha}(I))$ for any arc $I \subset W^u(p)$ as μ^u is holonomy-invariant. Recall,

that μ^u is a smooth Lebesgue measure. Consequently, $\tilde{\alpha} : W^u(p) \rightarrow W^u(p)$ is a translation of \mathbb{R} and therefore $\{\tilde{\alpha} \mid \alpha \in \pi_1(M)\}$ is a free abelian group. Let $\tilde{\alpha}$ be the identity and $q \in W^u(p)$. Then $\pi_p : \{q\} \times W^s(p) \rightarrow W^s(q)$ is a covering map and since $W^s(q)$ is simply connected, α is the identity. Therefore, we have $\pi_1(M)$ is isomorphic to $\{\tilde{\alpha} \mid \alpha \in \pi_1(M)\}$ which is isomorphic to \mathbb{Z}^m for some $m \in \mathbb{N}$. \square

Lemma 2.58. *The set $\bigcup_{\alpha \in \pi_1(M)} \tilde{\alpha}(p)$ is dense in $W^u(p)$.*

Proof. Let $I \neq \emptyset$ be an open arc in $W^u(p)$. Hence $\pi_p(I, p)$ is open in $W^u(p) \subset M$ and since $W^s(p)$ is dense in M there exists $y \in W^s(p) \cap \pi_p(I, p)$. Then we can find $y_1 \in I$ and $y_2 \in W^s(p)$ such that $\pi_p(p, y_2) = \pi_p(y_1, p) = y$ and there exists α such that $\alpha(p, y_2) = (y_1, p)$, and hence $\tilde{\alpha}(p) = y_1 \in I$. \square

We define $F : \overline{M} \rightarrow \overline{M}$ by $F := f|_{W^u(p)} \times f|_{W^s(p)}$. The map F is a lift of f by π_p as it is $\pi_p \circ F = f \circ \pi_p$. The induced map F_{\sharp} on the fundamental group $\pi_1(M)$ is linear and as the orbit of the fundamental group for p is dense in $W^u(p)$, we can consider $F : W^u(p) \rightarrow W^u(p)$ to be a linear map, i.e. there exists $0 < \lambda < 1$ such that $\mu^u(F(I)) = \lambda^{-1}\mu^u(I)$. We denote with $\phi : \mathbb{Z}^m \rightarrow \pi_1(M)$ an isomorphism and define $A : \mathbb{Z}^m \rightarrow \mathbb{Z}^m$ by $A := \phi^{-1} \circ F_{\sharp} \circ \phi$. Now we construct a topological conjugacy H between F and A by mapping a point $x \in \mathbb{R}^m$ onto the unique point $y \in \overline{M}$ which is the shadowing orbit of $\{A^i x\}$.

Lemma 2.59. *The lifted map $F : \overline{M} \rightarrow \overline{M}$ is topologically conjugate to the hyperbolic linear map $A \in \text{GL}(m, \mathbb{Z})$.*

Proof. We define a bijection Φ from a lattice \mathbb{Z}^m of \mathbb{R}^m onto a lattice $\pi_p^{-1}(p)$ of \overline{M} by $\Phi(\alpha(0)) = \phi(\alpha)(p, p)$. Then it holds $F|_{\pi_p^{-1}(p)} \circ \Phi = \Phi \circ A|_{\mathbb{Z}^m}$ because by definitions the right side equals $F|_{\pi_p^{-1}(p)}(\phi(\alpha)(p, p)) = (F \circ \phi(\alpha))(p, p)$ and the left side equals $\Phi(\phi^{-1}(F(\phi(\alpha)))) = F(\phi(\alpha))(p, p)$. In order to construct the conjugacy utilizing the shadowing orbit we have to recover the pseudo-orbit tracing property of f for the lifted map F :

Lemma 2.60. *The map $F : \overline{M} \rightarrow \overline{M}$ has the pseudo-orbit tracing property with respect to the pullback \tilde{d} of the metric d of M .*

Proof. Let $\epsilon > 0$ and $\tilde{d}(Fx_i, x_{i+1}) < \epsilon$ for all $i \in \mathbb{Z}$ an ϵ -pseudo-orbit. Let $x_i = (x_i^1, x_i^2) \in \overline{M} = W^u(p) \times W^s(p)$. Because $F(x_i)$ and x_{i+1} are close their stable and unstable manifolds intersect in a unique point $(x_{i+1}^1, f(x_i^2))$ and the distance of the unstable segment $[f(x_i^1), x_{i+1}^1]$ is bounded for all $i \in \mathbb{Z}$. Thus we can find a constant $c > 0$ such that $\mu^u([f(x_i^1), x_{i+1}^1]) < c$ for all $i \in \mathbb{Z}$. So we get

$$\mu^u([f^{-i}x_i^1, f^{-i-1}x_{i+1}^1]) = f^{-i-1}\mu^u([f(x_i^1), x_{i+1}^1]) = \lambda^{-i-1}c.$$

Hence, the sequence $\{f^{-i}x_i^1\}_{i \geq 0}$ is a Cauchy sequence and there exists a unique limit point $x^1 = \lim_{i \rightarrow \infty} f^{-i}x_i^1 \in W^u(p)$. We can find points $z_i \in \{f^i x^1\} \times W^s(p)$ such that $\tilde{d}(z_i, x_i) < c'$ for all $i \in \mathbb{Z}$ for some $c' > 0$. Then the sequence $\{f^i z_i^2\}_{i \geq 0}$ is a Cauchy sequence in $W^s(p)$ and converges to a unique limit point $x^2 = \lim f^i z_i^2 \in W^s(p)$. So there exists a $\delta(\epsilon) > 0$ such that the orbit $\{F^i(x^1, x^2)\}$ $\delta(\epsilon)$ -shadows the ϵ -pseudo-orbit $\{x_i\}$. \square

Let $x \in \mathbb{R}^m$ and consider the orbit $\{A^i x\}_{i \in \mathbb{Z}}$. The maximal distance between points on the lattice and points of \mathbb{R}^m is $\frac{\sqrt{m}}{2}$. Hence, for $c > \frac{\sqrt{m}}{2}$ we find a sequence $\{x_i = \alpha_i(0)\}$ in \mathbb{Z}^m such that $\|A^i x - x_i\| < c$ for all $i \in \mathbb{Z}$. Then the sequence $\Phi(x_i)$ defines a L -pseudo-orbit of F for some $L > 0$. Applying Lemma 2.60 we can find $\delta > 0$ and $y \in \overline{M}$ such that $\tilde{d}(F^i(y), \Phi(x_i)) < \delta$ for all $i \in \mathbb{Z}$. Then we can define $H : \mathbb{R}^m \rightarrow \overline{M}$ by $H(x) = y$. It is an extension of Φ and it holds $F \circ H = H \circ A$ and $H \circ \alpha = \phi(\alpha) \circ H$. So it remains to show that it is continuous and has a continuous inverse.

Lemma 2.61. *The map H is continuous.*

Proof. Let $C > 0$. We show that for any $\epsilon > 0$ there is $N > 0$ such that if $\tilde{d}(F^i x, F^i y) \leq C$ for all $|i| \leq N$ then $\tilde{d}(x, y) < \epsilon$. For $x = (x_1, x_2), y = (y_1, y_2) \in \overline{M}$ we define $z(x, y) = (x_1, y_2) \in \overline{M}$. As the stable and unstable foliation are transverse to each other we can find a constant $K > 0$ such that $\tilde{d}^s(x, z(x, y)) \leq K$ and $\tilde{d}^u(y, z(x, y)) \leq K$ if $\tilde{d}(x, y) \leq C$ where \tilde{d}^s denotes the intrinsic metric of $\{x_1\} \times W^s(p)$ and \tilde{d}^u the intrinsic metric of $W^u(p) \times \{y_2\}$. If $\tilde{d}(F^{-N}x, F^{-N}y) \leq C$, then it follows $\tilde{d}^s(F^{-N}x, F^{-N}z(x, y)) = \tilde{d}^s(F^{-N}x, z(F^{-N}x, F^{-N}y)) \leq K$. So we get by the contraction along the stable direction $\tilde{d}^s(x, z(x, y)) < \epsilon$ for N sufficiently big. In an analogous way it follows that if $\tilde{d}(F^N x, F^N y) \leq C$ then it is $\tilde{d}^u(y, z(x, y)) < \epsilon$ if N is sufficiently big. \square

Up to now, the map A is only known to be a linear map. To construct an inverse of H we have to show that A is in fact hyperbolic:

Lemma 2.62. *The linear map $A \in \text{GL}(m, \mathbb{Z})$ is hyperbolic.*

Proof. Suppose A is not hyperbolic. Then there exists a $x \in \mathbb{R}^m \setminus \{0\}$ such that $\|Ax\| = \|x\|$. Hence, the whole orbit $\{A^i x\}$ is bounded. This implies that $\{F^i H(x)\}$ is also bounded. But then it is $H(x) = (p, p)$ and - since H is an extension of Φ - it is $x = 0$. \square

Due to the hyperbolicity of A we can construct an inverse of H by repeating the procedure above for the map A instead of F . We can construct $H' : \overline{M} \rightarrow \mathbb{R}^m$ in the same way such that we obtain $A \circ H' = H' \circ F$

and $H' \circ \alpha = \phi^{-1}(\alpha) \circ H'$ for all $\alpha \in \pi_1(M)$. So H' is the inverse of H . So we have showed that A is topologically conjugate to F by the homeomorphism H . As H is a homeomorphism the dimensions has to be equal, i.e. $m = q$. \square

Lemma 2.63. *The toral automorphism $\phi_A : \mathbb{T}^q \rightarrow \mathbb{T}^q$ is topologically conjugate to $f : M \rightarrow M$.*

Proof. The map H projects directly to a topological conjugacy h between f and ϕ_A . \square

Clearly, M is homeomorphic to \mathbb{T}^q by the projected homeomorphism h . \square

2.6 Codimension-(2+2) center Foliation

In this last section we drop the restriction of a one-dimensional unstable direction. The conjecture that every center leaf with non-trivial holonomy might be isolated is not true as we show in the following. Further, we need more than a 2-cover to eliminate leaves with non-trivial holonomy.

First, we take the 4-fold orientation cover of M such that E^s and E^u are oriented. We can show that center leaves with non-trivial holonomy are isolated, and therefore there exists only a finite number of them. The following theorem states the content of Theorem D(1).

Theorem 2.64. *Let $f : M \rightarrow M$ be a partially hyperbolic system with an invariant compact center foliation \mathcal{W}^c with finite holonomy. Assume $\dim E^s = \dim E^u = 2$ and assume that E^s and E^u are oriented. Then center leaves with non-trivial holonomy are isolated.*

Proof. We show that for any holonomy homeomorphism $H_\gamma = H_\gamma^s \times H_\gamma^u$ it holds that the period of H_γ^s equals the period of H_γ^u and that therefore every non-trivial holonomy homeomorphism with period n is conjugated to a rotation by $\frac{2\pi}{n}$ times a rotation by $\frac{2\pi}{n}$. It follows that center leaves with non-trivial holonomy are isolated. We define

$$A := \{W^c(x) \mid \exists \gamma : H_\gamma = \text{id} \times H_\gamma^u\},$$

where $H_\gamma^u \neq \text{id}$, and we show that the set A is empty. Let $W^c(x) \subset A$. Then there exists a closed path γ such that $H_\gamma = \text{id} \times H_\gamma^u$. Then consider $y \in T_x^s$. As the center foliation is compact with finite holonomy, the Reeb stability Theorem 1.6 can be applied and $p : W^c(y) \rightarrow W^c(x)$ is a covering space.

2.6. Codimension-(2+2) center Foliation

Then $y \in T_x^s$ is fixed by $\text{id} \times H_\gamma^u$ and as the holonomy group of $W^c(y)$ equals the isotropy group of $\text{Hol}(W^c(x), x)$ which fixes y the group $\text{Hol}(W^c(y), y)$ contains a element $\text{id} \times H_\gamma^u$. Accordingly, $T_x^s \subset A$, and the set is locally \mathcal{W}^{cs} -saturated.

Lemma 2.65. *The set A is closed in \mathcal{W}^{cs} .*

Proof. Let $U_x \subset T_x^s$ be an open set such that $U_x \subset A$ and consider a sequence $x_n \in U_x$ such that $y := \lim x_n \in \delta U_x$. Then for sufficiently big $n \geq N$ the map $p : W^c(x_n) \rightarrow W^c(y)$ is a covering space. For every $W^c(x_n)$, $n \geq N$, the holonomy group of $W^c(x_n)$ is isomorphic to a subgroup of $\text{Hol}(W^c(y), y)$ such that x_n are fixed by the respective subgroup. Hence, we find $\gamma \in \pi_1(W^c(y), y)$ and a sequence $n_k \rightarrow \infty$ such that $x_{n_k} \rightarrow y$ and $x_{n_k} \in U_x \subset T_x^s$ is fixed by H_γ . Then, the orientation-preserving period map H_γ^s has an arc of fixed points and has to be therefore the identity. Assume $H_\gamma^u \equiv \text{id}$, then this contradicts the fact that $W^c(x_{n_k}) \subset A$. Hence, we get $W^c(y) \subset A$. \square

As $W^{cs}(x)$ is non-compact it accumulates at $z \in M$ and $W^c(z) \subset A$. Then $W^{cs}(x)$ intersects T_z^u infinitely many times in one foliated chart neighborhood of z such that the intersecting points accumulates at z . The holonomy group of $W^c(x)$ contains an element $\text{id} \times H_\gamma^u$ where $H_\gamma^u \neq \text{id}$. At the same time, the holonomy group $\text{Hol}(W^c(x), x)$ is isomorphic to the subgroup of $\text{Hol}(W^c(z), z)$ which fixes $W^c(x)$. The intersection points $W^{cs}(x) \cap T_z^u$ accumulate at z . For every intersection point x_i we denote with $p_i : W^c(x_i) \rightarrow W^c(z)$ the covering map and with $\gamma_i \in \pi_1(W^c(x_i), x_i)$ a closed path such that $H_{\gamma_i} = \text{id} \times H_{\gamma_i}^u$. Accordingly, we find a closed path $\gamma \in \pi_1(W^c(z), z)$ and a sequence i_n such that $H_{p_{i_n}, \# \gamma_{i_n}} = H_\gamma$ and $H_\gamma(x_{i_n}) = x_{i_n}$. As $H_\gamma = H_\gamma^s \times H_\gamma^u$ it is implied that $H_\gamma^u \equiv \text{id}$ and $H_\gamma^s = H_{p_{i_n}, \# \gamma_{i_n}}^s \equiv \text{id}$. Consequently, every element $H_{\gamma_i} \equiv \text{id}$ contradicting that $W^c(x_i) \in A$. Therefore A is empty.

The analogous argument can be applied to the set

$$A' := \{W^c(x) \mid \exists \gamma : H_\gamma = H_\gamma^s \times \text{id}\}$$

Because of Theorem 1.14 every non-trivial holonomy homeomorphism H^s and H^u respectively is conjugate to a rotation by $\frac{2\pi}{n}$ and therefore isomorphic to a subgroup of the orthogonal group $O(2)$. So, we can understand the leaf space M/\mathcal{W}^c as an orbifold with isolated singular points x whose neighborhood U_x is homeomorphic to \mathbb{R}^4/Γ_x where $\Gamma_x = \Gamma_x^s \times \Gamma_x^u$ and $\Gamma_x^s < O(2)$, $\Gamma_x^u < O(2)$. Both groups Γ_x^s and Γ_x^u have the same order. \square

The unstable bundle E^u is not oriented. In this paragraph we assume the further property of central transitivity which is necessary for the proof of Lemma 2.68.

Theorem 2.66. *Let $f : M \rightarrow M$ be a centrally transitive partially hyperbolic C^1 -diffeomorphism with a compact f -invariant center foliation. Assume $\dim E^s = \dim E^u = 2$, E^s is oriented and E^u is not oriented. Further, assume that the center holonomy is trivial in the 2-cover \tilde{M} of orientation of E^s and E^u . Then the center leaves have only trivial holonomy.*

Proof. The maximal order of every center holonomy group is two and is therefore generated by a single non-trivial element. This non-trivial holonomy homeomorphism can be either $H_\gamma = \text{id} \times S$, where S denotes a reflection along an arc in the unstable bundle, or $H_\gamma = R_\pi \times S$ where R_π denotes a rotation by π in the stable bundle. We consider first the following sets

$$A := \{W^c(x) \mid |\text{Hol}(W^c(x), x)| = 2\} \text{ and}$$

$$A_1 := \{W^c(x) \mid \exists \gamma : H_\gamma = R_\pi \times S\} \subset A.$$

In the following two lemmata we show that both sets A_1 and A are empty which implies that the holonomy of the center foliation is trivial and hence, proves Theorem 2.66.

Lemma 2.67. *The set A_1 as defined above is empty.*

Proof. The set A is closed and f -invariant, the set A_1 is also f -invariant as the period of any holonomy homeomorphism is preserved by f , and it is closed by the Reeb Stability Theorem 1.6. Assume $W^c(x) \subset A_1$. There exists $\gamma \in \pi_1(W^c(x), x)$ which generates any non-trivial holonomy homeomorphism H_γ and there exists an arc $\Sigma_x \subset W^u(x)$ which is fixed by H_γ . Hence, it is $\Sigma_x \subset A_1$. But Σ_x is stretched under f^n and hence it accumulates at a center leaf $W^c(z) \subset A_1$ such that $f^n \Sigma_x$ intersects infinitely many times T_z^s accumulating at z . Then there exists a sequence $x_{n_k} \subset f^n \Sigma_x \cap T_z^s$ accumulating at z and $H_\gamma^s(x_{n_k}) = x_{n_k}$ for some $\gamma \in \pi_1(W^c(z), z)$. But then $H_\gamma^s \equiv \text{id}$ and with this $H_\gamma \equiv \text{id}$ as $W^c(z) \subset A_1$ is implied contradicting the fact that $W^c(x_{n_k}) \subset A_1$. So, A_1 is empty. □

Hence, we can conclude that

$$A := \{W^c(x) \mid \exists \gamma : H_\gamma = \text{id} \times S\}.$$

In the following lemma we show that the set A is empty.

Lemma 2.68. *The set A as defined above is empty.*

Proof. The set A is closed and f -invariant. It is \mathcal{W}^{cs} -saturated and foliated by arcs $\Sigma_x \subset W^u(x)$ for every $x \in A$. Hence, we get that A is foliated by two transverse f -invariant foliations. The normal direction must be included in the unstable direction. If we lift A to \tilde{A} in the 2-cover \tilde{M} of orientation of E^u and if we project \tilde{A} to the leaf space \tilde{M}/\tilde{W}^c we obtain a F -invariant 3-dimensional manifold \tilde{A}/\tilde{W}^c foliated by the 2-dimensional stable foliation $\pi\mathcal{W}^{cs}$ and by a 1-dimensional unstable foliation. Hence, the submanifold \tilde{A}/\tilde{W}^c has to be a repeller. The central transitivity of f implies that $A = M$. As leaves with trivial holonomy are generic, we obtain that A is empty. \square

Therefore, the holonomy of the center foliation is trivial. \square

The unstable bundle E^u and the stable bundle E^s are not oriented.
The following theorem states the content of Theorem D(2):

Theorem 2.69. *Let $f : M \rightarrow M$ be a centrally transitive partially hyperbolic C^1 -diffeomorphism with a compact f -invariant center foliation. Assume $\dim E^s = \dim E^u = 2$, both bundles are not oriented and there exists a holonomy homeomorphism reversing the orientation of at least one bundle. Further, assume that the center holonomy is trivial in the 4-fold cover \tilde{M} of orientation of E^s and E^u . Then there exist invariant 2-tori T in the leaf space \tilde{M}/\tilde{W}^c and $F|_T$ is conjugate to a hyperbolic toral automorphism.*

Proof. We define as usual the set

$$A := \left\{ W^c(x) \mid |\text{Hol}(W^c(x), x)| = \max_{y \in M} |\text{Hol}(W^c(y), y)| \right\}$$

of center leaves with a holonomy group of maximal order. The set A is f -invariant and closed. If we lift A to \tilde{A} in the 2-cover \tilde{M}^s of orientation of E^s we can apply Theorem 2.66 above and conclude that \tilde{A} is empty. The same result is obtained by lifting A to the 2-cover \tilde{M}^u of orientation of E^u .

Therefore, we can conclude that any non-trivial holonomy homeomorphism reverses the orientation of E^s and E^u at the same time and hence, it is 2-periodic in the stable and unstable direction. Then there exists $\gamma \in \pi_1(W^c(x), x)$ which generates any non-trivial holonomy homeomorphism $H_\gamma = H_\gamma^s \times H_\gamma^u$. Two line segments $\Sigma_x^s \subset T_x^s$ and $\Sigma_x^u \subset T_x^u$ are fixed by H_γ . Then $\Sigma_x^s \subset A$ and $\Sigma_x^u \subset A$. Let $y \in \Sigma_x^s$. Then by the Reeb Stability Theorem 1.6 $p : W^c(y) \rightarrow W^c(x)$ is a cover. As $y \in \Sigma_x^s$ is fixed by the whole holonomy group $\text{Hol}(W^c(x))$, the holonomy group $\text{Hol}(W^c(y))$ is equal to $\text{Hol}(W^c(x))$. Hence, we have $\Sigma_x^s, \Sigma_x^u \subset A$ for any $x \in A$, and we get two transverse

one-dimensional foliations of A . Both foliations are f -invariant. If we lift A to the cover \tilde{M} of orientations of E^s and E^u and project it to the leaf space $\tilde{M}/\tilde{\mathcal{W}}^c$ any connected component $\tilde{A}_0/\tilde{\mathcal{W}}^c$ of $\tilde{A}/\tilde{\mathcal{W}}^c$ is a compact submanifold of a 4-manifold foliated by two transverse one-dimensional foliations without compact leaves and hence a 2-torus T . The set $\tilde{A}/\tilde{\mathcal{W}}^c$ is F -invariant, hence, there exists k such that the tori T are F^k -invariant. As F is expansive, $F^k|_T$ is expansive. Lewowicz in [Lew89] showed that the map $F^k|_T$ is then conjugate to a hyperbolic toral automorphism. \square

The following examples illustrate both cases of isolated center leaves with non-trivial holonomy and of invariant tori of center leaves with non-trivial holonomy.

Example 2.70. Let $A \in \text{SL}(2, \mathbb{Z})$ be a hyperbolic matrix with double eigenvalues $0 < \lambda < 1 < \mu$. Define the following hyperbolic matrix F_A by $\text{diag}(A, A, \text{id}) \in \text{GL}(5, \mathbb{Z})$ which induces a partially hyperbolic torus automorphism f_A on \mathbb{T}^5 with a one-dimensional compact center foliation $\{x\} \times \mathbb{S}^1$.

Let $B := \begin{pmatrix} 0 & -\text{id} & 0 \\ \text{id} & 0 & 0 \\ 0 & 0 & 1 \end{pmatrix} \in \text{GL}(5, \mathbb{Z})$. Then f_A commutes with $H := B +$

$\begin{pmatrix} 0 & 0 & 0 & 0 & \frac{1}{4} \end{pmatrix}^T$. Then $\mathbb{T}^5/Hx \sim x$ is a manifold with a partially hyperbolic diffeomorphism F_A induced by f_A . The leaf space of the center foliation is a 4-orbifold with four singular points,

$$\left(\frac{1}{2}, \frac{1}{2}, \frac{1}{2}, \frac{1}{2}\right), \left(\frac{1}{2}, 0, \frac{1}{2}, 0\right), \left(0, \frac{1}{2}, 0, \frac{1}{2}\right), (0, 0, 0, 0)$$

with non-trivial holonomy H of order four and twelve singular points of order two.

Example 2.71. Let $F_A \in \text{SL}(5, \mathbb{Z})$ be the hyperbolic matrix of the Example 2.70 above which induces a partially hyperbolic torus automorphism f_A on \mathbb{T}^5 with a one-dimensional compact center foliation $\{x\} \times \mathbb{S}^1$. Let $B :=$

$\begin{pmatrix} \text{id} & 0 & 0 \\ 0 & -\text{id} & 0 \\ 0 & 0 & 1 \end{pmatrix}$. Then f_A commutes with $H := B + \begin{pmatrix} 0 & 0 & 0 & 0 & \frac{1}{2} \end{pmatrix}^T$. Then

$\mathbb{T}^5/Hx \sim x$ is a manifold with a partially hyperbolic diffeomorphism F_A induced by f_A . The leaf space of the center foliation is a 4-orbifold with four tori of singular points:

$$\left\{ \left\{ \begin{pmatrix} x_1 \\ x_2 \\ a \\ b \end{pmatrix} \mid x_1, x_2 \in \mathbb{R}/\mathbb{Z} \right\}, \quad a, b = 0, \frac{1}{2} \right\}$$

Outlook

We have showed in the present work that it is possible to recover a lot of hyperbolic dynamical features in the leaf space of a compact center foliation with finite holonomy of a partially hyperbolic diffeomorphism $f : M \rightarrow M$, although it is in generality a compact metric space without further structure. Despite the lack of any differentiable structure in the leaf space it is possible to utilize the differentiable structure in the original manifold M and the existence of f -invariant foliations in M to prove interesting and far-reaching dynamical properties of the induced dynamic on the leaf space as transitivity, the pseudo-orbit tracing property and hyperbolicity. In the future it might be interesting to investigate further properties of the induced dynamics on the leaf space as ergodicity or entropy.

The better understanding of the interplay between the dynamics on the leaf space and the original partially hyperbolic dynamic on M can help to classify partially hyperbolic systems with a compact f -invariant center foliation with finite holonomy. The question what the typical partially hyperbolic system with a compact invariant center foliation (dropping the assumption of finite holonomy) looks like was one motivation which stands behind this thesis. To treat this case in more generality than in the present work the next step would be to achieve a better knowledge of the possible holonomy groups of a compact center foliation. It might be conjectured that the holonomy group of a compact center leaf has to be isomorphic to a subgroup of the linear orthogonal group, acting linearly on the transversal, and that hence, the leaf space has always an orbifold structure. The proof of that conjecture would allow us to use a lot of established results of foliation theory and to narrow the possibilities of compact center foliations and therewith of partially hyperbolic systems with a compact center foliation.

Bibliography

- [BBI04] M. Brin, D. Burago, and Ivanov. On partially hyperbolic diffeomorphisms on 3-manifolds with commutative fundamental group, 2004.
- [Bin52] R.H. Bing. A homeomorphism between the 3-sphere and the sum of two solid horned spheres. *Ann. of Math.*, 56(2):354–362, 1952.
- [Boc45] S. Bochner. Compact groups of differentiable transformations. *Ann. of Math. (2)*, 46:372–381, 1945.
- [Bow75] R. Bowen. In *Equilibrium states and the ergodic theory of Anosov diffeomorphisms*, volume 470 of *Lecture Notes in Math.* Springer, 1975.
- [BP74] M. I. Brin and Ja. B. Pesin. Partially hyperbolic dynamical systems. *Izv. Akad. Nauk SSSR Ser. Mat.*, 38:170–212, 1974.
- [Bro19] L. E. J. Brouwer. Über die periodischen Transformationen der Kugel. *Mathematische Annalen*, 80:39–41, 1919.
- [BW05a] C. Bonatti and A. Wilkinson. Transitive partially hyperbolic diffeomorphisms on 3-manifolds. *Topology*, 44(3):475–508, 2005.
- [BW05b] K. Burns and A. Wilkinson. Better center bunching, 2005.
- [BW08] K. Burns and A. Wilkinson. Dynamical coherence and center bunching. *Discrete Contin. Dyn. Syst.*, 22(1-2):89–100, 2008.
- [Car10] P. Carrasco. *Compact dynamical foliations*. PhD thesis, University of Toronto, 2010.
- [CC00] A. Candel and L. Conlon. *Foliations I*, volume 23 of *Graduate Studies in Mathematics*. American Mathematical Society, Providence, RI, 2000.

Bibliography

- [CK94] A. Constantin and B. Kolev. The theorem of Kerékjártó on periodic homeomorphisms of the disc and the sphere. *Enseign. Math.*, 40(3-4):193–204, 1994.
- [Con78] C. Conley. *Isolated invariant sets and the Morse index*, volume 38 of *CBMS Regional Conference Series in Mathematics*. American Mathematical Society, Providence, R.I., 1978.
- [DH72] P.F. Duvall and L.S. Husch. Analysis on topological manifolds. *Fundamenta Mathematicae*, 77(1):75–90, 1972.
- [Eil34] S. Eilenberg. Sur les transformations périodiques de la surface de sphère. *Fund. Math.*, 22:28–41, 1934.
- [EMT77] D.B.A. Epstein, K. Millet, and D. Tischler. Leaves without holonomy. *Journal of the London Mathematical Society*, s2-16(3):548–552, 1977.
- [Eps72] D.B.A. Epstein. Periodic flows on three-manifolds. *Ann. of Math.*, 95:66–82, 1972.
- [Eps76] D.B.A. Epstein. Foliations with all leaves compact. *Ann. Inst. Fourier (Grenoble)*, 26(1):265–282, 1976.
- [EV78] D.B.A. Epstein and E. Vogt. A counterexample to the periodic orbit conjecture in codimension 3. *Ann. of Math.*, 108(3):539–552, 1978.
- [Fra70] J. Franks. Anosov diffeomorphisms. In *Proceedings of Symposia in Pure Mathematics*, volume 14, pages 61–94. AMS, 1970.
- [Gog11] A. Gogolev. Partially hyperbolic diffeomorphisms with compact center foliations, 2011.
- [Gou07] N. Gourmelon. Adapted metric for dominated splittings. *Ergodic Theory Dynam. Systems*, 27(6):1839–1849, 2007.
- [Gun05] R. Gunesch. Dynamische systeme. Lecture Notes WS 05/06, 2005.
- [Hec77] G. Hector. Feuilletages en cylindres. In *Geometry and topology (Proc. III Latin Amer. School of Math., Inst. Mat. Pura Aplicada CNPq, Rio de Janeiro, 1976)*, pages 252–270. Lecture Notes in Math., Vol. 597. Springer, Berlin, 1977.

-
- [Hir71] M. Hirsch. Invariant subsets of hyperbolic sets. In David Chillingworth, editor, *Proceedings of the Symposium on Differential Equations and Dynamical Systems*, volume 206 of *Lecture Notes in Mathematics*, pages 90–91. Springer, 1971.
- [Hir89] K. Hiraide. Expansive homeomorphisms with pseudo-orbit tracing property on n -torus. *J. Math. Soc. Japan*, 41(3):357–389, 1989.
- [Hir01] K. Hiraide. A simple proof of the franks-newhouse theorem on codimension-one anosov diffeomorphisms. *Ergodic Theory Dynam. Systems*, 21:801–806, 2001.
- [HK95] B. Hasselblatt and A. Katok. *Introduction to the modern theory of dynamical systems*. Cambridge University Press, New York, 1995.
- [HPS70] M. W. Hirsch, C. Pugh, and M. Shub. Invariant manifolds. *Bull. Amer. Math. Soc.*, 76:1015–1019, 1970.
- [HRHU10] F. Rodriguez Hertz, M. A. Rodriguez-Hertz, and R. Ures. A non-dynamically coherent example in 3-torus. Preprint, 2010.
- [Kne24] H. Kneser. Reguläre Kurvenscharen auf den Ringflächen. *Math. Ann.*, 91(1–2):135–154, 1924.
- [Lew89] J. Lewowicz. Expansive homeomorphisms of surfaces. *Bol. Soc. Brasil. Math. (N.S.)*, 20(1):113–133, 1989.
- [Mañ84] Ricardo Mañé. Oseledec’s theorem from the generic viewpoint. In *Proceedings of the International Congress of Mathematicians, Vol. 1, 2 (Warsaw, 1983)*, pages 1269–1276, Warsaw, 1984. PWN.
- [Mar70] G.A. Margulis. Certain measures associates with u -flows on compact manifolds. *Functional Anal. Appl.*, 4:55–67, 1970.
- [Mil75] K. C. Millett. Compact foliations. In *Differential topology and geometry (Proc. Colloq., Dijon, 1974)*, pages 277–287. Lecture Notes in Math., Vol. 484. Springer, Berlin, 1975.
- [MM03] I. Moerdijk and J. Mrcun. *Introduction to Foliations and Lie Groupoids*. Cambridge University Press, 2003.

Bibliography

- [Mon37] D. Montgomery. Pointwise periodic homeomorphisms. *American Journal of Mathematics*, 59(1):pp. 118–120, 1937.
- [MZ54] D. Montgomery and L. Zippin. Examples of transformation groups. *Proc. Amer. Math. Soc.*, 5:460–465, 1954.
- [New31] M.H.A. Newman. A theorem on periodic transformations of spaces. *Quart. J. Math.*, 2, 1931.
- [New70] S. E. Newhouse. On codimension one Anosov diffeomorphisms. *Amer. J. Math.*, 92:761–770, 1970.
- [Omb86] J. Ombach. Equivalent conditions for hyperbolic coordinates. *Topology App.*, 23(1):87–90, 1986.
- [Pes77] Ja. B. Pesin. Characteristic Ljapunov exponents, and smooth ergodic theory. *Uspehi Mat. Nauk*, 32(4 (196)):55–112, 287, 1977.
- [PS72] C. Pugh and M. Shub. Ergodicity of Anosov actions. *Invent. Math.*, 15:1–23, 1972.
- [PS96] Charles Pugh and Michael Shub. Stably ergodic dynamical systems and partial hyperbolicity. *Journal of Complexity*, 13:125–179, 1996.
- [Ree52] G. Reeb. *Sur certaines propriétés topologiques des variétés feuilletées*. Actualités Sci. Ind., no. 1183. Hermann & Cie., Paris, 1952. Publ. Inst. Math. Univ. Strasbourg 11, pp. 5–89, 155–156.
- [Sul76a] D. Sullivan. A counterexample to the periodic orbit conjecture. *Inst. Hautes Études Sci. Publ. Math.*, (46):5–14, 1976.
- [Sul76b] D. Sullivan. A new flow. *Bull. Amer. Math. Soc.*, 82(2):331–332, 1976.
- [Thu76] W.P. Thurston. Existence of codimension-one foliations. *Ann. of Math.*, 104(2):249–268, 1976.
- [Vie99] J. Vieitez. A 3D-manifold with a uniform local product structure is T3. *Publ. Mat. Urug.*, 8:47–62, 1999.
- [vK19] B. von Kerékjártó. Über Transformationen des ebenen Kreisringes. *Mathematische Annalen*, 80:33–35, 1919.
- [Wil98] A. Wilkinson. Stable ergodicity of the time-one map of a geodesic flow. *Ergodic Theory Dynam. Systems*, 18(6):1545–1587, 1998.

Zusammenfassung

Diese Arbeit beschäftigt sich mit den Eigenschaften von partiell hyperbolischen Diffeomorphismen mit einer kompakten Zentrumsblätterung, deren Blätter jeweils endliche Holonomie besitzen. Die Theorie der partiell hyperbolischen dynamischen Systeme ist in den 1970er Jahren als Erweiterung der hyperbolischen dynamischen Systeme entstanden. Da der Begriff der partiellen Hyperbolizität in erster Linie theoretisch motiviert ist, gibt es bisher ein ungenügendes Verständnis davon, wie partiell hyperbolische Systeme konkret aussehen und welches die relevanten Beispiellklassen sind. Dennoch lassen bisherige Arbeiten vermuten, dass partiell hyperbolische Systeme mit kompakter Zentrumsblätterung, die Gegenstand dieser Arbeit sind, einen wichtigen Teil der partiell hyperbolischen Systeme umfassen, der derzeit auch aus anderen Gründen von großem wissenschaftlichen Interesse ist, beispielsweise bei Beschäftigung mit SRB-Maßen.

Folgende Resultate werden in dieser Arbeit erzielt: Sei $f : M \rightarrow M$ ein partiell hyperbolischer Diffeomorphismus auf einer kompakten Mannigfaltigkeit M mit einer kompakten Zentrumsblätterung \mathcal{W}^c mit endlicher Holonomie. Dann gilt für den von f auf dem Quotientenraum M/\mathcal{W}^c induzierten Homöomorphismus F das Beschattungslemma. Unter der weiteren Annahme, dass die instabile bzw. stabile Richtung eindimensional ist, ist F transitiv. Wenn der Diffeomorphismus f auf eine 2-Überlagerung \tilde{M} geliftet wird, dann definiert die Quotientenabbildung $\pi : \tilde{M} \rightarrow \tilde{M}/\tilde{\mathcal{W}}^c$ ein Faserbündel und \tilde{f} induziert auf der Basis $\tilde{M}/\tilde{\mathcal{W}}^c$ einen Homöomorphismus, der zu einem hyperbolischen Torusautomorphismus konjugiert ist. Die Zentrumsblätter mit nichttrivialer, endlicher Holonomie können genau identifiziert werden: Es sind endlich viele, die auf periodischen Orbits des Diffeomorphismus liegen. Eine direkte Verallgemeinerung des Ergebnisses auf partiell hyperbolische Systeme beliebiger Dimensionen ist nicht möglich: Es gibt Beispiele von Systemen der Kodimension $(2+2)$, bei denen die Zentrumsblätter mit nichttrivialer Holonomie Untermannigfaltigkeiten bilden, und andere Beispiele, bei denen es nicht ausreicht, das System auf eine 2-Überlagerung zu liften, um die nichttriviale Holonomie zum Verschwinden zu bringen.

Lebenslauf

Persönliche Daten

Name Doris Bohnet geb. Plate
E-Mail dorisbohnet@gmx.de
Geburstag 10. Januar 1982 in Konstanz
Familienstand verheiratet, 2 Kinder (*02.06.2004, *29.05.2010)

Schulische Ausbildung

1988-1992 Grundschule Wollmatingen in Konstanz
1992-1997 Heinrich-Suso-Gymnasium in Konstanz
1997-1998 Colegio Agropecuario in Ambato, Ecuador
1998-2001 Alexander-von-Humboldt-Gymnasium in Konstanz
Juni 2001 Abitur

Studium

2001-2002 Diplomstudium der Chemie an der HU Berlin
2001-2007 Magisterstudium der Philosophie an der HU Berlin, TU Berlin
und der Universität Hamburg
Januar 2007 Abschluss als Magistra Artium mit einer Magisterarbeit unter
Betreuung von Prof. Dr. Ulrich Gähde
2002-2008 Diplomstudium der Mathematik an der TU Berlin
und der Universität Hamburg
März 2008 Abschluss mit Diplom mit einer Diplomarbeit unter
Betreuung von Dr. Roland Gunesch und Prof. Dr. Reiner Lauterbach

Beruflicher Werdegang

seit April 2008 wissenschaftliche Mitarbeiterin im Department Mathematik
der Universität Hamburg

Stipendien

2001-2002 Stipendium des Verbandes der chemischen Industrie
2009 DAAD-Auslandsstipendium für Doktoranden für einen
Forschungsaufenthalt an der Northwestern University in Evanston, USA