



HAL
open science

Polyaniline and its derivatives doped with Lewis acids - synthesis and spectroscopic properties.

Krzysztof Bienkowski

► **To cite this version:**

Krzysztof Bienkowski. Polyaniline and its derivatives doped with Lewis acids - synthesis and spectroscopic properties.. Other. Université Joseph-Fourier - Grenoble I; Warsaw University of Technology, 2006. English. NNT: . tel-00084184

HAL Id: tel-00084184

<https://theses.hal.science/tel-00084184>

Submitted on 5 Jul 2006

HAL is a multi-disciplinary open access archive for the deposit and dissemination of scientific research documents, whether they are published or not. The documents may come from teaching and research institutions in France or abroad, or from public or private research centers.

L'archive ouverte pluridisciplinaire **HAL**, est destinée au dépôt et à la diffusion de documents scientifiques de niveau recherche, publiés ou non, émanant des établissements d'enseignement et de recherche français ou étrangers, des laboratoires publics ou privés.

Warsaw University of Technology
Joseph Fourier University – Grenoble I



POLYANILINE AND ITS DERIVATIVES
DOPED WITH LEWIS ACIDS -
SYNTHESIS AND SPECTROSCOPIC
PROPERTIES

Krzysztof Bieńkowski

A DISSERTATION IN CHEMISTRY

Thèse soutenue le **17 mars 2006** à Varsovie

Directeurs de thèse :

Mme Françoise GENOUD (Grenoble)

Mme Irena KULSZEWICZ-BAJER (Varsovie)

Jury:

M. Mikolaj SZAFRAN

M. Jeremiasz JESZKA

M. Wincenty TUREK

Mme Françoise GENOUD

Mme Irena KULSZEWICZ-BAJER

M. Jean Louis ODDOU

M. Adam PRON

Président

Rapporteur

Rapporteur

Directeur de thèse (Grenoble)

Directeur de thèse (Varsovie)

Examineur

Examineur

Acknowledgements

This “co-tutelle” thesis was done within the framework of collaboration between French Atomic Energy Commission in Grenoble (CEA); Joseph Fourier University, Grenoble I (UJF) and Warsaw University of Technology (PW). The work was carried out in two research units: Department of Chemistry and Technology of Polymers, which is part of Faculty of Chemistry of PW and Laboratory of Physics of Synthetic Metals, part of Department of Fundamental Research on Condensed Matter (DRFMC) of CEA.

I would like to address my thanks to heads of the above units: Mr Zbigniew Floriańczyk (Poland) and Mr Jean-Pierre Travers (France), who enabled me to work in excellent scientific environment.

I would like to thank my Polish supervisor, Ms Irena Kulszewicz-Bajer for her assistance at all stages of my Ph.D. studies. I am also extremely grateful that she encouraged me to study in France.

I would like to thank my French supervisor, Ms Françoise Genoud for her support during my stay in Grenoble. I appreciate possibilities of scientific self-improvement that she created for me.

I am very impressed with extraordinary personality of Mr Adam Pron (CEA Grenoble). Collaboration with him was not only fruitful from scientific point of view, but also became particularly agreeable thank his great sense of humour. It is also hard not to appreciate his role in broadening of my scientific horizons.

I am particularly indebted to Mr Jean-Louis Oddou (CEA Grenoble). I always admired his rare ability to explain nuclear physic in a way understandable for chemists. This virtue combined with his knowledge and warm personality made our Mössbauer spectroscopy studies a real scientific adventure for me.

I would like to thank Ms Małgorzata Zagórska (PW Warsaw) for her extreme patience and kind help during my Ph.D. studies. Her wide knowledge allowed me to solve not only scientific problems, but also was essential in finding right way through forest of Polish and French bureaucracy.

I would like to address special words of gratefulness to Mr Maciej Śniechowski (Academy of Mining and Metallurgy, Cracow and Institute Laue-Langevin, Grenoble) and Mr David Djurado (CEA Grenoble) for X-ray measurements as well as for computer modelling studies performed. I am especially appreciating Mr Śniechowski’s influence on my knowledge of physical chemistry.

I would like to thank Ms Colette Lebrun for mass spectroscopy measurements and important aid in interpretation of the obtained results.

I am also grateful to other members of my both Polish and French laboratories for their collaboration allowing me preparation of the thesis in present form.

I am indebted to Ms Alice Corre for her hospitality and care during my stay in Grenoble. I also owe my positive perception of France to her.

Preparation of this thesis would have been impossible without encouragement and support of my family and friends. I thank them from the bottom of my heart.

TABLE OF CONTENTS

<i>I Preface</i>	5
<i>II Introduction to polyanilines chemistry</i>	7
II.1 Polyaniline – introduction	7
II.2 Synthetic routes to polyaniline	9
<i>II.2.1 Chemical oxidative polymerisation</i>	9
<i>II.2.2 Electrochemical polymerisation</i>	11
<i>II.2.3 Polycondensation</i>	11
II.3 Mechanism of aniline oxidative polymerisation	12
II.4 Polyaniline derivatives	15
II.5 Aniline oligomers	16
II.6 Principles of polyaniline doping	18
II.7 Polyanilines processibility and conductivity	20
<i>II.7.1 Doping induced processibility of polyaniline</i>	21
<i>II.7.2 Properties of PANI doped with (\pm)-camphor-10-sulfonic acid</i>	24
<i>II.7.3 Polyaniline chain functionalisation</i>	25
<i>II.7.4 Spectroscopic properties of polyaniline doped with Lewis acids</i>	26
<i>III Experimental</i>	31
III.1 Experimental techniques	31
<i>III.1.1 High and low temperatures</i>	31
<i>III.1.2 Primary and high vacuum equipment</i>	31
a) Pumping unit.....	31
b) Vacuum line.....	32
c) Vacuum glassware	32
<i>III.1.3 Dry Box</i>	33
<i>III.1.4 Glove Bag</i>	33
<i>III.1.5 Elemental Analyses</i>	33
<i>III.1.6 Spectroscopic Equipment</i>	34
a) UV-Vis-NIR spectroscopy.....	34
b) Infrared spectroscopy	34
c) Electron Paramagnetic Resonance (EPR) spectroscopy	34
d) Nuclear Magnetic Resonance (NMR) spectroscopy.....	34
e) Mössbauer effect spectroscopy	34
f) Mass spectroscopy.....	35
g) X-ray investigations.....	35
<i>III.1.7 Other techniques</i>	35
a) Centrifuge	35
b) Viscosity measurements	35
III.2 Preparation of reagents	35
<i>III.2.1 Purification of reagents and solvents</i>	35
<i>III.2.2 Dopant synthesis</i>	36
a) Preparation of chlorobis(acetylacetonato)iron(III)	37
b) Preparation of dichloro(acetylacetonato)aluminum(III)	38
<i>III.2.3 Synthesis of polyanilines</i>	39
a) Polyaniline (emeraldine, PANI).....	39
b) Polyanisidine (PANIZ)	40
c) Poly(2-ethylaniline) (P2EA)	40
<i>III.2.4 Synthesis of aniline tetramer</i>	41

III.3 Doping and dedoping of polyaniline and its derivatives	41
<i>III.3.1 Doping procedures</i>	<i>41</i>
a) Doping with AlCl_3	42
b) Doping with $\text{AlCl}_2(\text{acac})$	42
c) Doping with FeCl_3	42
d) Doping with FeCl_3 in the presence of hexafluoroacetylacetone	43
e) Doping with $\text{FeCl}(\text{acac})_2$	43
<i>III.3.2 Dedoping procedures.....</i>	<i>43</i>
IV Results and discussion	45
IV.1 Characterisation of pristine polyanilines and their model compound – tetramer of aniline	45
<i>IV.1.1 Introduction.....</i>	<i>45</i>
<i>IV.1.2 Elemental analyses.....</i>	<i>45</i>
<i>IV.1.3 Viscosity measurements</i>	<i>46</i>
<i>IV.1.4 X-ray investigations</i>	<i>47</i>
<i>IV.1.5 UV-Vis-NIR studies.....</i>	<i>51</i>
<i>IV.1.6 IR studies.....</i>	<i>52</i>
IV.2 Doping of polyanilines and tetramer of aniline with iron (III) chloride	56
IV.3 Doping of polyaniline and its derivatives with iron(III) chloride in the presence of hexafluoroacetylacetone	65
<i>IV.3.1 Mixed doping of polyaniline with iron (III) chloride in the presence of hexafluoroacetylacetone</i>	<i>65</i>
<i>IV.3.2 Mixed doping of polyaniline derivatives with iron (III) chloride in the presence of hexafluoroacetylacetone – a comparative study.....</i>	<i>75</i>
IV.4 Doping of polyaniline and its derivatives with chlorobis(acetylacetonato)iron(III).....	78
IV.5 Doping of polyaniline and its derivatives with aluminium (III) chloride	86
IV.6 Doping of polyanilines with dichloro (acetylacetonato)aluminium(III).....	92
V Conclusions.....	98
VI Appendix A – Principles of the Mössbauer effect spectroscopy	99
VI.1 Introduction.....	99
VI.2 Application of Doppler effect in Mössbauer spectroscopy.....	101
VI.3 Mössbauer parameters	101
VI.4 Basic Mössbauer equipment	103
VII Summary	104
VIII Resume	105
IX Streszczenie.....	106
X References	107

I PREFACE

Polyaniline has been known since XIX century [1,2], however the research devoted to this polymer was rather rare and not systematic till the beginning of 80's of the past century. High electronic conductivity of doped polyaniline was known for years [3], but the conductive polymers, usually prepared in a form of powders which were impossible to process into more useful technological forms, could not compete with classical conductors of similar type such as different types of carbon blacks etc. An increasing interest in polyaniline chemistry, physics and engineering observed in the past 20 years, is a consequence of the development of the “conducting polymer science” which started in 1977 by the discovery of unusual electronic properties of polyacetylene – the simplest conjugated polymer. The importance of this domain of research was underlined by the attribution of the Nobel Prize in chemistry in 2000 to its founders - Heeger, Mac Diarmid and Shirakawa.

Several research efforts have been undertaken to improve the processibility of the most important conducting polymers [4]. In the case of polyaniline, the simplest approach consisted in the design of special type of dopants of the Brönsted acid nature, which in addition to rendering the polymer conductive induced its solution or thermal processibility in the doped (conducting) state. This approach was first demonstrated by Cao et al. in 1992 who used *n*-dodecylbenzene sulfonic acid (DBSA) as a processibility improving dopant [5]. The introduction of long aliphatic chains as inherent parts of the doping anions facilitated the dissolution of the conducting form of the polymer in non-polar solvents. Several other groups of dopants have later been developed, which depending on their chemical constitution facilitated different types of polyaniline processing [6,7,8,9,10,11]. All of them were however of Brönsted acid nature.

Emeraldine – the semi-oxidized form of polyaniline studied in this research - can be considered not only as a Brönsted base, but also as a Lewis one. As a consequence, it can in principle, be doped by complexation with appropriate Lewis acids. In the elucidation of this type of polyaniline doping two important questions must be addressed:

- Can Lewis acid complexation improve solution processibility of polyaniline?
- How this process influences the electronic conductivity of this polymer?

This is a promising area of research taking into account successful solubilisation attempts of some Lewis base type polymers (for example polyazomethines) using Lewis acid complexation, as reported by Jenekhe [12]. It seems also highly probable that the

doping of polyaniline with Lewis acids should lead to an increase of its conductivity similarly as it does in the case of Brönsted acid doping. The data concerning Lewis acid complexation of polyaniline are scarce. Kulszewicz-Bajer and co-workers in 1999 and 2000 [13,14] reported on polyaniline complexation with SnCl_4 and FeCl_3 , whereas Kumar studied the complexation of this polymer with BF_3 [15]. It was shown that polyaniline doped with SnCl_4 or FeCl_3 is soluble in acetonitrile and nitromethane i.e. in solvents, which dissolve neither the base form of polyaniline, nor the Brönsted acid doped one.

The main goal of this thesis was to elucidate the process of Lewis acid complexation of polymers from the polyaniline family and to establish the influence of this doping on their processing, spectroscopic and electronic properties. The second aim was to identify various chemical processes, which accompany the doping. The studies were not limited to unsubstituted polyaniline, but extended to the Lewis acid complexation of its ring substituted derivatives such as poly(2-ethylaniline) and polyanisidine. As dopants two families of complexing agents of the following general formulae were used:

$\text{AlCl}_{3-x}(\text{acac})_x$ and $\text{FeCl}_{3-x}(\text{acac})_x$ i.e. Al(III) and Fe(III) complexes either with chloride ligands or with mixed chloride – acetylacetonate ligands.

II INTRODUCTION TO POLYANILINES

CHEMISTRY

II.1 POLYANILINE – INTRODUCTION

Polyaniline (PANI) has been known from the beginning of XIX century as “aniline black” [1,2,16]. It was used as a dye to blacken cotton fabrics. At the beginning of the XX century number of works [17,18,19] were realised with aim to resolve PANI structure. Initially, aniline black was considered as an aniline octamer in different oxidation states. Lately, it was shown that oxidation of aniline under certain conditions gives a polymer. It was Woodhead and Green who named three basic polyaniline forms (described below), these names are commonly used till today.

An important breakthrough in the polyaniline research took place in early 1980s, when polyaniline has been discovered as a member of a novel group of macromolecular compounds; namely conductive polymers [20,21]. Since then, it has become the most extensively studied polymer in this group.

In reality, “polyaniline” is a name for whole family of polymers, which can be described by the formula presented in *fig. II.1.1*.

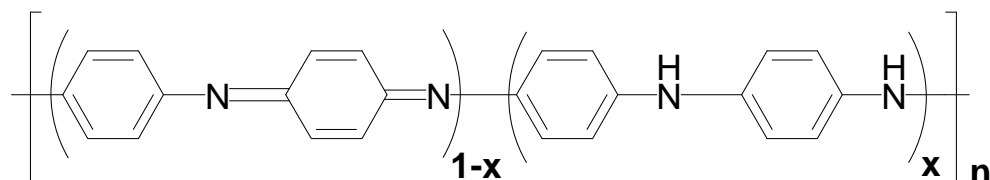

Fig. II.1.1 General formula for different forms of polyaniline base

Correctness of the formula presented above was proved, among others, by spectroscopic studies of Wudl and co-workers [22,23].

As already mentioned, three principal forms of polyaniline can be distinguished (fig.II.1.2). All these forms exhibit interesting spectroscopic properties, but two of them – fully reduced (a) and fully oxidised (c) (fig. II.1.2) are environmentally instable. Leucoemeraldine (a) (white powder) is a strong reducing agent that easily reacts with air oxygen giving emeraldine (b) as the product [24]. Pernigraniline (c) (red-purple, partially crystalline powder) composed of oxidised units, easily undergoes hydrolytic type degradation via chain scission [25]. Emeraldine base (dark blue powder with metallic gloss) – semi-oxidized form of PANI - is stable in air and can be stored for long time without chemical changes. Emeraldine is the most extensively studied form of polyaniline.

Thus, in the majority of publications, names “polyaniline” and “emeraldine” are used interchangeably.

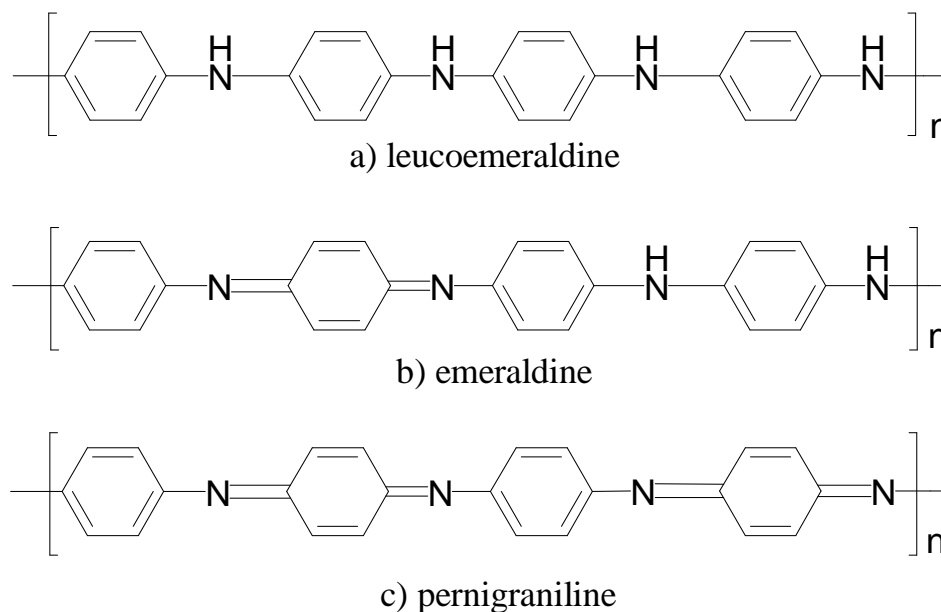

Fig. II.1.2 Principal forms of polyaniline base

In the case of PANI – contrary to other conjugated systems – contribution to the conjugation is given not only by π -electrons of aromatic rings (π - π interaction), but also by interactions between the lone electron pairs of nitrogen atoms and π electrons (p- π interactions). Additionally, in emeraldine base relatively strong interactions between amine and imine groups in neighbour chains via hydrogen bonds are present [26, 27]. These phenomena are responsible for very difficult processibility of polyanilines in the base form.

Partial dissolution of PANI base is possible only when solvent – polymer hydrogen bond interactions replace interchain interactions. Few solvents dissolve emeraldine base, for example: NMP (N-methyl pyrrolidinone), TMU (tetramethylurea), DMA (N,N-dimethylacetamide). In concentrated PANI solutions gelation process is sometimes observed. To inhibit this process a mixture of solvents can be applied (combination of electron donors and acceptors that interact with amine and imine groups, respectively). Conjugation as well as the presence of hydrogen bonds cause not only insolubility in majority of common solvents, but also is the reason why PANI is infusible. At high temperatures (above 400 °C) polymer gradually decomposes without melting.

Polyaniline in its base form exhibits the electrical conductivity lower than 10^{-6} S/cm. The poor conductivity is limited by the band gap between HOMO and LUMO

levels, i.e. 3,8 eV. It is possible to convert PANI into the conducting form. This problem will be discussed in the chapter devoted to the doping process.

II.2 SYNTHETIC ROUTES TO POLYANILINE

Polymerisation process of aniline and its derivatives has been investigated for more than one century and several synthetic routes have been proposed. Due to the fact that only emeraldine base is stable in ambient conditions, the most popular polymerisation procedures are aimed on the preparation of this form. When pernigraniline or leucoemeraldine are required, the oxidation or the reduction of emeraldine usually obtains them.

II.2.1 Chemical oxidative polymerisation

The oldest and still the most popular way for the preparation of polyaniline is chemical oxidative polymerisation. Optimisation of the process was widely investigated during the past two decades. Several papers devoted to the aniline polymerisation in organic solvents have been published [28], but the reaction in aqueous solutions at low pH has still been the most extensively studied. Different inorganic oxidants such as: KIO_3 , KMnO_4 , FeCl_3 , K_2CrO_4 , KBrO_3 , KClO_3 , $(\text{NH}_4)_2\text{S}_2\text{O}_8$ were tested. Reactions were carried out in different acids (i.e. HCl , H_2SO_4 , HClO_4). The effect of the temperature of the reaction medium and acid concentration were also investigated as variables of the process. It turned out that the temperature has a specially pronounced influence on the properties of the obtained product and in particular, on its molecular weight. According to Adams and his co-workers [29] polyaniline obtained at 18 °C has $M_w=4200$ Da, $M_n=3000$ Da, the polymer synthesised at 0 °C has $M_n=20400$ Da, $M_w=122000$ Da, PANI obtained at -25 °C has $M_n=43500$ Da, $M_w=209000$ and for polyaniline obtained at -35 °C $M_n=19100$ Da, $M_w=166000$ Da. Thus, there exists no need of the reaction temperature decrease below -25 °C since upon further temperature lowering the macromolecular parameters of the polymer worsen.

Another important parameter influencing the properties of the resulting polymer is the monomer to oxidant molar ratio. This problem was investigated by Pron and co-workers [30]. Due to the fact, that different oxidants are capable to accept different number of electrons, these authors proposed a unified coefficient k (eq.II.1). It was found that coefficient k has to be $\gg 1$ (large excess of aniline), when a good quality polymer is required. The necessity of the use of a large excess of aniline can be rationalised by the mechanism of the polymerisation.

$$(eq.II.1) \quad k = \frac{2,5 \cdot n_{aniline}}{el \cdot n_{oxidant}}$$

where: 2,5 – number of electrons exchanged when aniline is oxidised to polyemeraldine (per one aniline molecule), *el*- number of electrons accepted by one molecule of the oxidant, $n_{oxidant}$ – number of moles of oxidant, $n_{aniline}$ – number of moles of aniline.

Aniline is first polymerised to pernigraniline, which is then reduced to emeraldine by the reaction with the excess of the monomer (see chapter II.4). The use of additional reducing agents, such as FeCl₂ facilitates the reduction of pernigraniline; the values of *k* can be lower in this case, but still higher than 1.

Chemical oxidative polymerisation of aniline using HCl and (NH₄)₂S₂O₈ can be described by the following chemical equation:

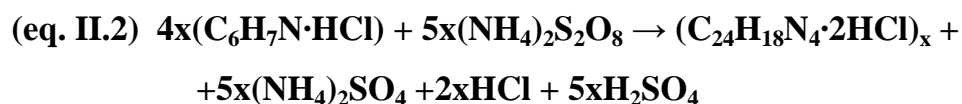

It is clear from eq.II.2 that in acidic media emeraldine is obtained in its protonated state. If needed, it is usually transformed into the base form by deprotonation in 0,1M ammonia aqueous solution.

Several interesting modifications of the oxidative polymerisation of aniline have been developed. In the emulsion polymerisation the organic phase consists of the solvent, aniline and the protonating agent, usually a functionalised sulfonic acid. The water phase contains the oxidant (usually ammonium persulfate). The polymer is formed in the organic phase and does not precipitate since it is protonated with acids containing solubilising substituents. As a result, solution processible polyaniline with a relatively high molecular weight can be obtained in a one-step process [31].

A new approach of the oxidative polymerisation of aniline is the enzymatic polymerisation [32]. Horseradish peroxydase / H₂O₂ system was used to oxidise the monomer molecules. An important element of the reaction environment was sulfonated polystyrene, which was used as a template to favour “para” coupling of aniline units. Polyaniline/sulfonated PS complex was soluble in water. The conductivity of the reaction product was ca. 0,1 S/cm. The main disadvantage of this method is difficulty in the separation of both polymers.

II.2.2 Electrochemical polymerisation

Oxidative polymerisation of aniline can also be performed using the electrochemical route. First papers describing successful electrochemical polymerisation of aniline were published in early 1960s [33].

Polyaniline can be synthesised potentiostatically, galvanostatically or by potential scanning (cyclic-voltammetry polymerisation). In the cyclic-voltammetry method the product is deposited layer-by layer on the anode. Using this technique the best quality homogenous polymer film was obtained in the eutectic mixture $\text{NH}_4\text{F}\cdot 2,35\text{HF}$ applying the potential from $-0,2\text{V}$ to $0,7\text{ V}$ (vs. Cu/CuF_2) [34, 35].

Electrochemical polymerisation can also be carried out in other media:

- aqueous solutions at low pH using inorganic acids such as HCl or H_2SO_4 [20,36, 37,38];
- The systems composed of organic solvents and inorganic salts, i.e. lithium perchlorate-acetonitrile [39,38].

Electrochemical polymerisations are usually carried out at room temperature, but some comparative experiments have been done at $0\text{ }^\circ\text{C}$ [40]. It has been found that the polymer obtained at lower temperatures exhibits better properties, among others, a higher molecular weight.

Well-controlled conditions of the electrochemical polymerisation cause good reproducibility of the product. Moreover, the oxidation state of the polymer can easily be modified when changing the potential of the working electrode. Unfortunately, small quantities of obtained PANI (comparing to chemical polymerisation) eliminate this method when bigger polyaniline quantities are required.

II.2.3 Polycondensation

The coupling reactions between benzene derivatives disubstituted with $-\text{NH}_2$ and/or $-\text{Br}$ groups in the presence of an appropriate catalyst lead to polyaniline as a product. Contrary to other methods the polymer structure can be modified by choosing suitable monomers; comparative experiments using “meta” and “para” isomers were performed (*vide infra*).

One of the most studied polycondensation methods was Ullmann condensation. In these syntheses different reagent combinations can be used: 1,4 or 1,3- phenylenediamine and 1,4 or 1,3- dibromobenzene in the presence of CuI [41]. Unfortunately, the product was infusible and only partly soluble in NMP. The other method consists of amination of

aryl bromide using Ni or Pd catalysts. Pomerantz et al.[42] have used p-bromoaniline. Kanabara et al. [43] used 1,3-dibromobenzene, 1,3- phenylenediamine and Pd catalyst (fig.II.2.1). Similarly, the condensation of bis(4-bromophenyl)amine in the presence of Ni catalyst leads to the formation of well defined structure of polyaniline [44].

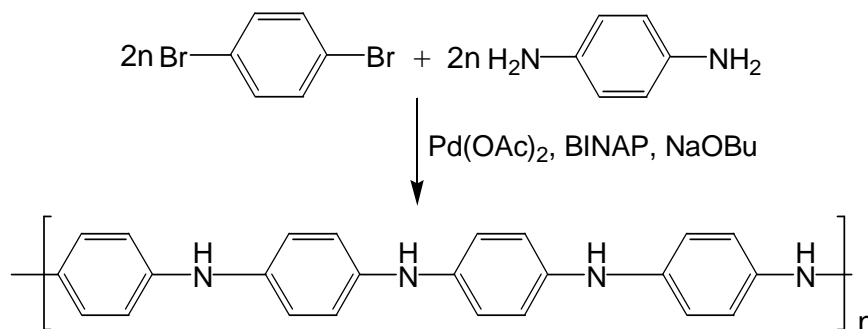

Fig. II.2.1 Synthesis of leucoemeraldine by polycondensation using 1,4-phenylenediamine and 1,4-dibromobenzene

The parameters of polyaniline synthesised on a polycondensation route are generally inferior to that obtained in the chemical synthesis. Moreover, as it was shown in fig.II.2.1, the polycondensation product is obtained as fully reduced (unstable) form of PANI.

II.3 MECHANISM OF ANILINE OXIDATIVE POLYMERISATION

Mechanism of oxidative polymerisation was investigated by many authors [45,46,47,48]. Independently on the proposed mechanism, it is believed that the polymerisation is initiated by the oxidation of the monomer to a radical cation (stabilised by resonance)(fig. II.3.1).

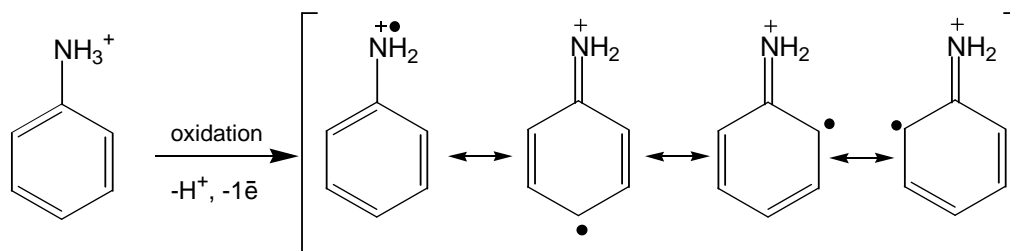

Fig. II.3.1 The formation of aniline radical cation

In the next step two coupling mechanisms are proposed:

- The electrophilic substitution of the formed radical cation to a neutral molecule of aniline (fig. II.3.2)

- Dimerisation of two radical cations (fig. II.3.3)

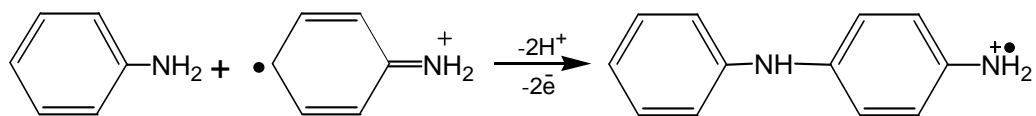

Fig. II.3.2 First stage of chain propagation

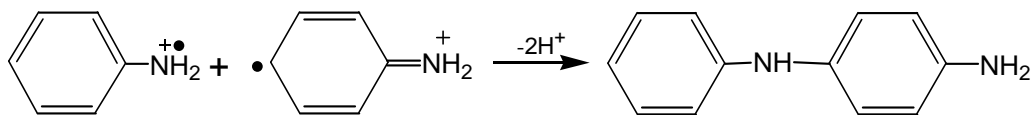

Fig. II.3.3 The coupling of two radical cations

In further discussions of the mechanism author will limit itself to the latter case, which is more widely accepted in the literature.

In the propagation step, the dimer is being oxidised to a radical cation and then it can couple with the radical cation formed by the oxidation of the monomer (fig.II.3.4) or with another dimer-type radical cation.

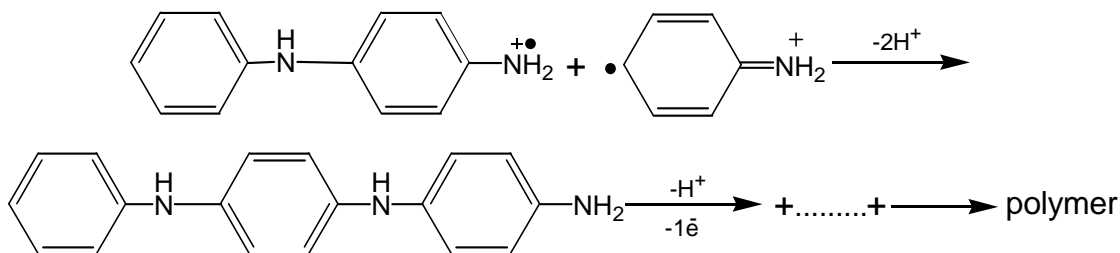

Fig. II.3.4 Propagation of the polyaniline chain

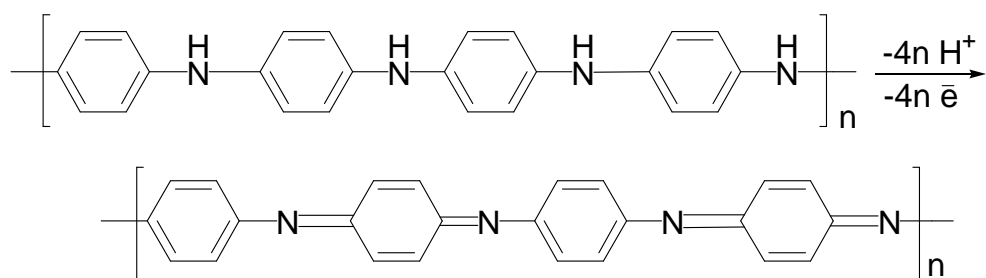

Fig. II.3.5 Oxidation of leucoemeraldine to pernigraniline

The polymer chain obtained via the above-described coupling is formally in the most reduced state (leucoemeraldine form). In reality, during the propagation step, it undergoes further oxidation to pernigraniline, as schematically depicted in fig. II.3.5.

The radical cations of aniline formed in this polymer reduction process either initiate the growth of a new chain or alternatively can participate in propagation of already growing chain.

In the next step the totally oxidised polymer is being reduced to the semi-oxidised state of emeraldine in red-ox reaction with the monomer (fig. II.3.6)

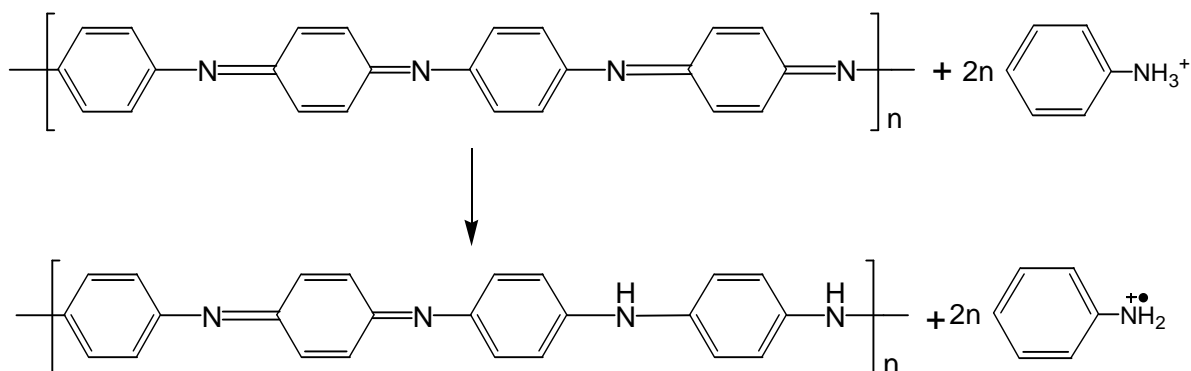

Fig.II.3.6 Propagation of the polyaniline chain

The polymer as depicted in fig. II.3.6 is in its basic form. In reality, in the highly acidic reaction medium it undergoes protonation of the imine nitrogens (fig. II.3.7).

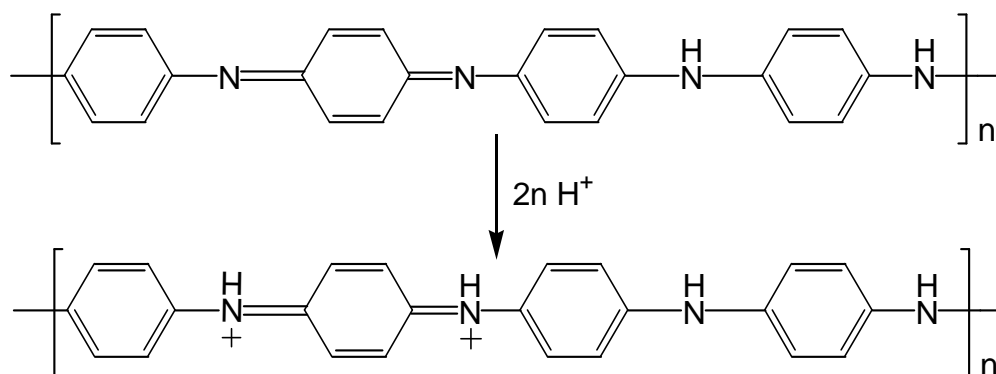

Fig.II.3.7 Protonation of the emeraldine

At the end, it should be mentioned that beside idealised formation of p-coupled PANI chain in the reactions described above, some side reactions were also identified [49](fig.II.3.8).

- coupling of aniline and its oligomers in “ortho” position;
- formation of benzidine groups (“tail to tail” coupling);
- chlorine substitution in aromatic ring (in systems with HCl and LiCl or NaCl);
- formation of N=N bonds (azo groups);
- formation of N-C_{Ar} grafting bridges between chains;
- polymer hydrolysis (=O and –OH groups).

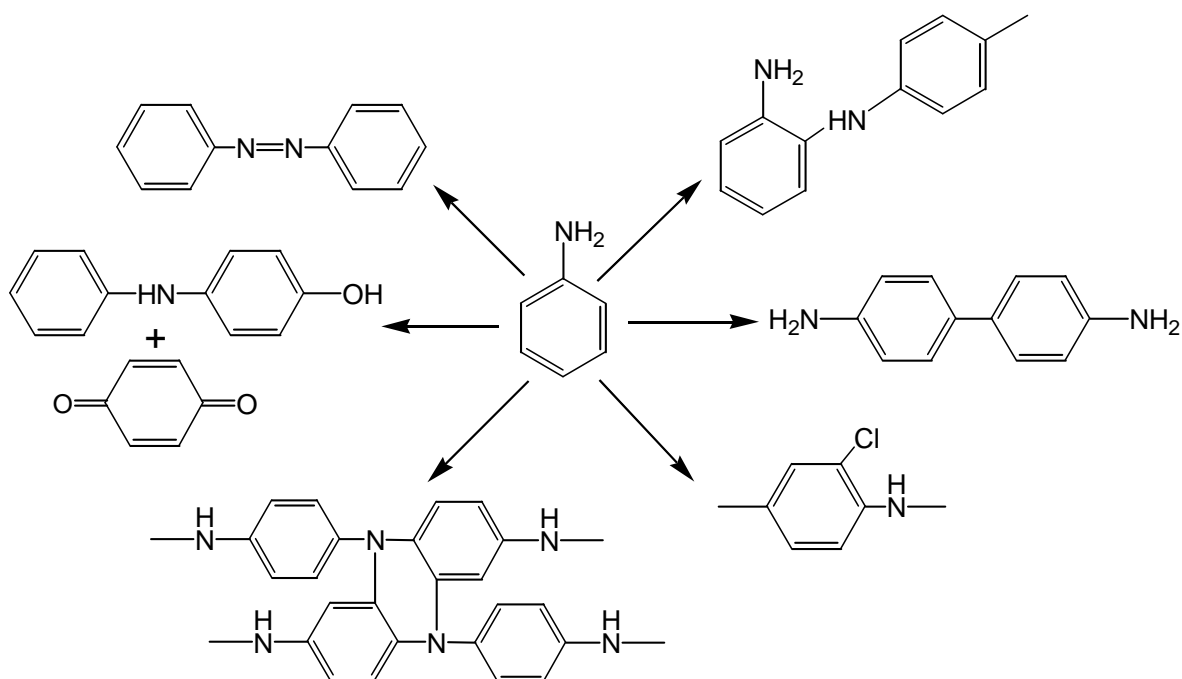

Fig. II.3.8 Side reactions occurring during polyaniline synthesis

All those reactions introduce undesirable elements to the structure of PANI and are considered as chain defects.

II.4 POLYANILINE DERIVATIVES

Polyaniline ring-substituted derivatives are known from the beginning of XX century. In 1910 Green and Woodhead studied the synthesis of 2-methyl substituted polyaniline, i.e. poly(o-toluidine)[18]. These polymers (fig.II.4.1) can be obtained using “ortho” as well as “meta” substituted aniline. The chain structures of the polymers obtained by the polymerisation of aniline derivatives, which differ only in the position of the side group (such as ortho-toluidine and meta-toluidine), seem to be almost identical independently whether the chemical synthesis or the electrochemical one is applied[50,51]. Small differences are caused mainly by the fact that in the case of o-substituted anilines one of the “ortho” positions is blocked - it diminishes the percentage of undesirable “ortho” coupling. The product has a more regular structure which, consequently, leads to higher polymerisation yields. “Para” substituted anilines do not polymerise [52], because long chain formation is blocked by the “para” substituent; the formation of oligomers is observed in this case.

For above reasons o-substituted anilines were chosen in this research as the monomers for the polymerisation and for the comparison with PANI.

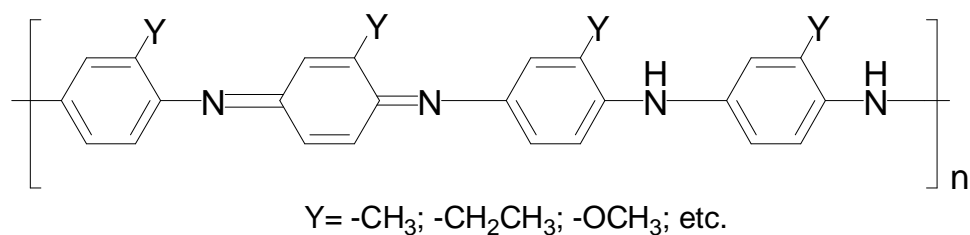

Fig. II.4.1 Ring substituted polyanilines in semi-oxidised form

The properties of the obtained polymers depend principally on the type and the size of substituent. An improvement in the solubilisation was one of the main goals of this research, so relatively flexible alkyl and alkoxy groups were chosen. Polymerisation of monomers with bulky side group improves solubility, but drastically decreases the molecular weight. This problem is discussed in chapter II.7. For this reason possibly small size groups (-CH₂CH₃ and -OCH₃) were incorporated.

It should be emphasised, that the methods applied for the syntheses of alkyl and alkoxy ring-substituted poly(amineimines) are generally the same as for polyaniline both in chemical as well as in electrochemical preparations. Similarly to the PANI case; chemical route (using ammonium persulfate) is frequently used. Moreover, it was shown [52,53] that the polymerisation mechanism of aniline and its ring-substituted derivatives is analogous.

Unfortunately, optimisation of the polymerisation process seems to be less developed comparing to the case of polyaniline, i.e. low temperature synthesis (below -5 °C) of ring-substituted polyaniline derivatives was not systematically investigated to date.

It may be noted, that other types of substituted poly(amineimines) were also obtained, namely N-substituted PANI derivatives (alkyl or phenyl as substituents), poly(2,3-dimethylaniline) and polyaniline derivatives with halogen atom attached to the aromatic ring.

II.5 ANILINE OLIGOMERS

Aniline oligomers are known almost as long as polyaniline. The synthesis of aniline tetramer was reported by Willstater and Moore in 1907 [54].

An increasing interest in oligoanilines is observed, because they can be considered as model compounds of polyaniline. The first and still the most investigated is the tetramer of aniline, i.e. the shortest oligomer bearing the properties of polyaniline structure (i.e. four aromatic rings and 4 nitrogen atoms). Other oligomers such as trimer, pentamer, hexamer, octamer were also obtained. Aniline oligomers can be divided into 3 groups (fig. II.5.1):

- End-capped with two phenylene rings (“Ph/Ph” type; fig. II.5.1a);
- End-capped with to two amine groups (“NH₂/NH₂” type; fig. II.5.1b);
- End-capped with one amine and one phenylene ring (“Ph/NH₂” type; fig. II.5.1c).

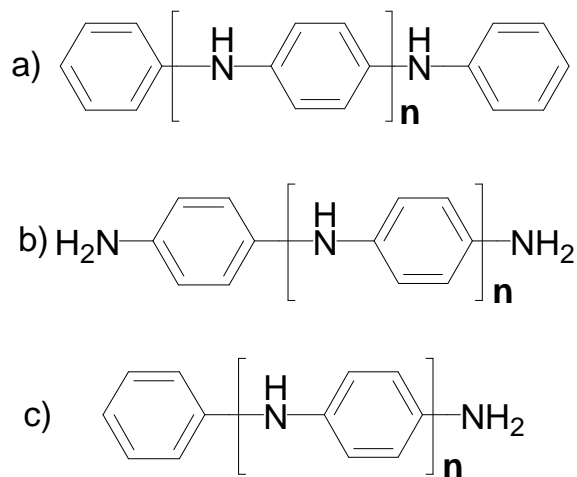

Fig. II.5.1 Three groups of aniline oligomers a) Ph/Ph end-capped, b) NH₂/NH₂ end-capped, c) Ph/NH₂ end-capped

Synthetic methods leading to oligoanilines of all three types mentioned above can generally be divided into two groups:

- Non-oxidative consecutive condensations are the first one. In this type of syntheses the obtained product has a well-defined molecular structure. Ullmann condensation and the condensation of aryl halides with corresponding amines in the presence of Ni or Pd catalysts belongs to this type of reaction [55,56];
- Oxidative synthesis is the second one. In this type of condensation aniline dimer i.e. N-phenyl-1,4-phenylenediamine is oxidised and coupled into tetramer.

First synthesis of Ph/Ph end-capped oligomer, namely tetramer (fig. II.5.2) was performed by Honzl in 1968 [57]. In this reaction p-aminodiphenylamine is condensed with diethyl succinoylsuccinate then, consequently, aromatisation, hydrolysis of both ester groups, and finally decarboxylation are performed. The authors also reported a successful hexamer synthesis.

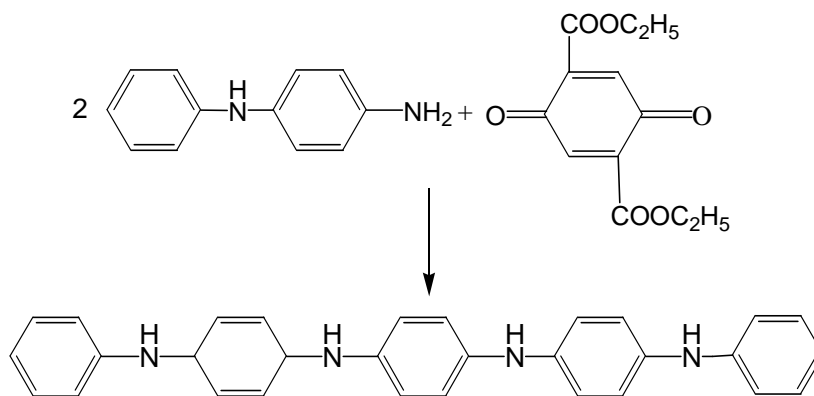

Fig. II.5.2 Honzl's synthesis of aniline tetramer

Simple oxidative synthesis of oligoanilines composed of even number of aromatic rings (Ph/NH₂ capped) was proposed by MacDiarmid and co-workers [58]. Reaction of N-phenyl-1,4-phenylene diamine monohydrochloride at 0 °C lead to semi-oxidised tetraaniline (fig. II.5.3).

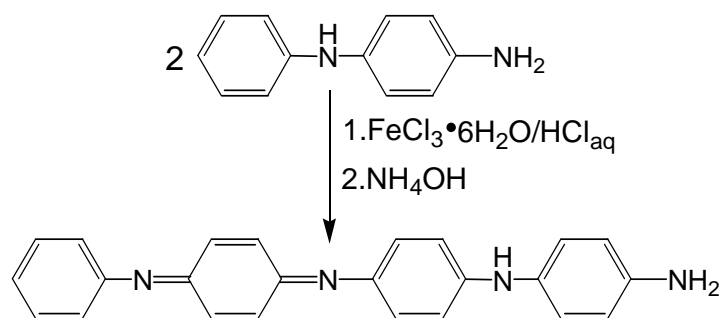

Fig. II.5.3 Oxidative synthesis of aniline Ph/NH₂ tetramer

This process – consisting of two relatively simple reactions - gives the desired product. Consecutive syntheses of octamer, hexadecamer etc. can be performed in a similar way, but before the oxidative coupling, additional reduction to “leucoemeraldine” form is required.

II.6 PRINCIPLES OF POLYANILINE DOPING

The term “doping”, widely used in the field of conductive polymers has its origin in semiconductor physics and denotes the process in which a semiconductor polymer is transformed into “an organic conductor”. Although phenomenologically similar to the case of inorganic semiconductors, the doping of conductive polymers exhibits a totally different chemical nature. Two types of dopings can be distinguished: the red-ox doping and the acid-base one. Both can be applied to polyaniline. The latter type of doping can be

performed using not only acids having acidic H^+ (Brönsted acids), but also can be extended to a wider group i.e. Lewis acids.

Polyaniline doping is schematically depicted in fig. II.6.1. Partial oxidation of non-conductive leucoemeraldine (fig.II.6.1a), leads to the formation of conductive emeraldine salt (fig.II.6.1b). The same product can be obtained by the protonation of emeraldine (fig.II.6.1d) [59]. Acid-base reaction is much more often applied due to air-sensitivity of leucoemeraldine.

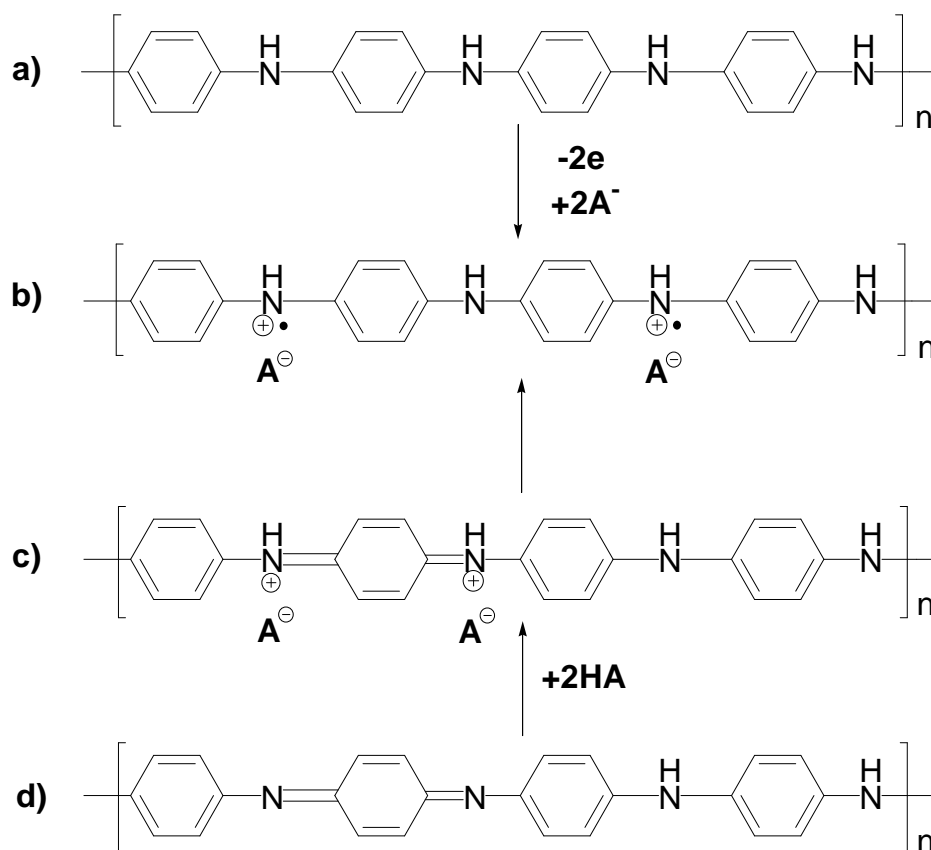

Fig.II.6.1 Principle of polyaniline doping

Formally, two stages can be distinguished in emeraldine protonation [60]. In the first one (fig.II.16c), imine groups of PANI are protonated with an acid; simultaneously anions that neutralise the positive charge of the chain are incorporated to the polymeric system.

The formed spinless dicationic species with quinoid-type sequence of bonds can be formally treated as a bipolaron. The positive charges in a form of dication are not stable for higher than $y=0,3$ doping levels (the doping level is defined as: $y=(mole\ acid)/(mole\ PANI)$ where PANI denotes average emeraldine repeat unit $C_6H_{4,5}N$). The interactions of positive charges with π electrons lead to a more uniform charge distribution, so called “polaron lattice” with strong resonant stabilisation energy (fig. II.6.1b). Thus, the highest protonation level does not exceed 0,5 for “ideal” emeraldine with 50% content of imine

sites. Such “saturated” system is usually denoted as PANI/(Acid)_{0,5} [61,62]. Both the oxidative doping of leucoemeraldine and the acid-base doping of emeraldine lead to p-type conductors in which charge carriers are positive.

Polyaniline can also be n-doped, in this process electrons from a reducing agent enrich the polymer chain. Only one paper devoted to this type of reaction concerning polyaniline was published to date [63]. The authors showed that such kind of doping is feasible, but applied reducing agents - KH and NaH - give as products K⁺ and Na⁺ doped PANI that is extremely unstable on air.

Nitrogen atoms of PANI have a lone electron pair, so PANI can be considered as a Lewis base. It was shown [13,14], that PANI treated with some Lewis acids forms acid-base complexes. Moreover, this type of doping is reversible. General structure of PANI base doped with Lewis acid (LA) is presented on fig. II.6.2. Similarly to the case of protonation, one molecule of dopant is coordinated to nitrogen atom, but contrary to the protonation, both types of nitrogen sites (amine as well as imine ones) are complexed. In this case the formation of a covalent or mixed ionic-covalent bond was postulated.

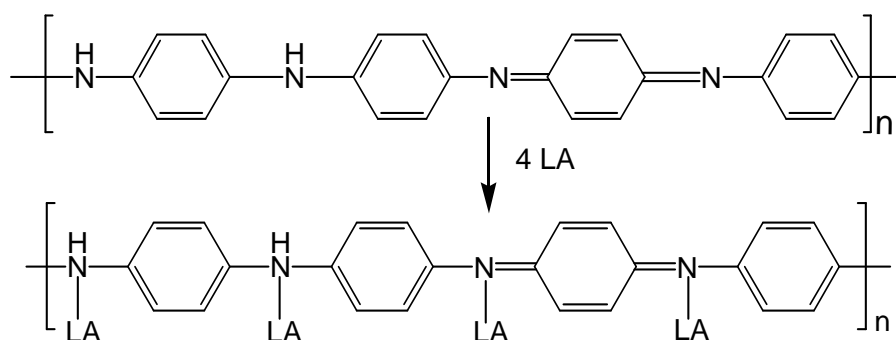

Fig.II.6.2 Lewis acid doping of emeraldine

II.7 POLYANILINES PROCESSIBILITY AND CONDUCTIVITY

Due to the fact, that polyaniline exhibits extremely interesting properties, improving of PANI processibility is an important part of the polymer research. Two main methods converting polyaniline to a soluble and/or fusible form were developed. The first one is the processibility induced by the doping with functionalised acids. The second one concerns incorporating of solubility inducing groups to the aromatic rings of the polymer.

II.7.1 Doping induced processibility of polyaniline

As it was mentioned above, polyanilines can be doped not only in red-ox reactions (as other conjugated systems) but also in acid (dopant) – base (polymer) reactions. This property makes PANI especially interesting from the practical point of view.

First compounds used for polyaniline doping were inorganic acids such as: HCl, H₂SO₄, H₃PO₄, and HClO₄. The most popular one was HCl, because this acid is non-oxidising and in addition it is volatile, so its excess can easily be removed. The electrical conductivity of polyaniline doped with HCl is ca. 1 S/cm, but this value depends strongly on molecular weight of polymer. Unfortunately, PANI doped with inorganic acids is neither soluble nor fusible.

The transformation of PANI into a processible polymer was achieved by the protonation of PANI with functionalised organic acids in so-called “doping induced processibility” process. The presence of bulky anion separates the polymer chains, diminishes interchain interactions and renders the polymer soluble. These observations can be extended to the vast majority of bulky protonic polyaniline dopants. In general, sulfonic acids and phosphoric acid diesters are used as dopants inducing the solubility of PANI.

Cao et al. [5] used n-dodecylbenzene acid (DBSA) (fig.II.7.1a) as a protonating agent of PANI. Acidic proton in -SO₃H group allows the protonation of the polymer; long hydrocarbon tail introduced with the dopant to the polymer matrix renders PANI/(DBSA)_{0.5} soluble in non-polar solvents and facilitates its supramolecular organisation in the solid state through interdigitation of the alkyl substituents [64].

(±)-camphor-10-sulfonic acid (CSA) (fig. II.7.1b) was found as a very convenient PANI solubilising dopant [5,65] This bicyclic compound exhibits extraordinary properties strongly depending on the medium used for the processing i.e. film casting. PANI/(CSA)_{0.5} films cast from chloroform exhibit a rather low conductivity, $\sigma \approx 10^{-1}$ S/cm. Films of PANI doped with the same dopant, but cast from m-cresol exhibit conductivity of ca. 200-300 S/cm [66,67].

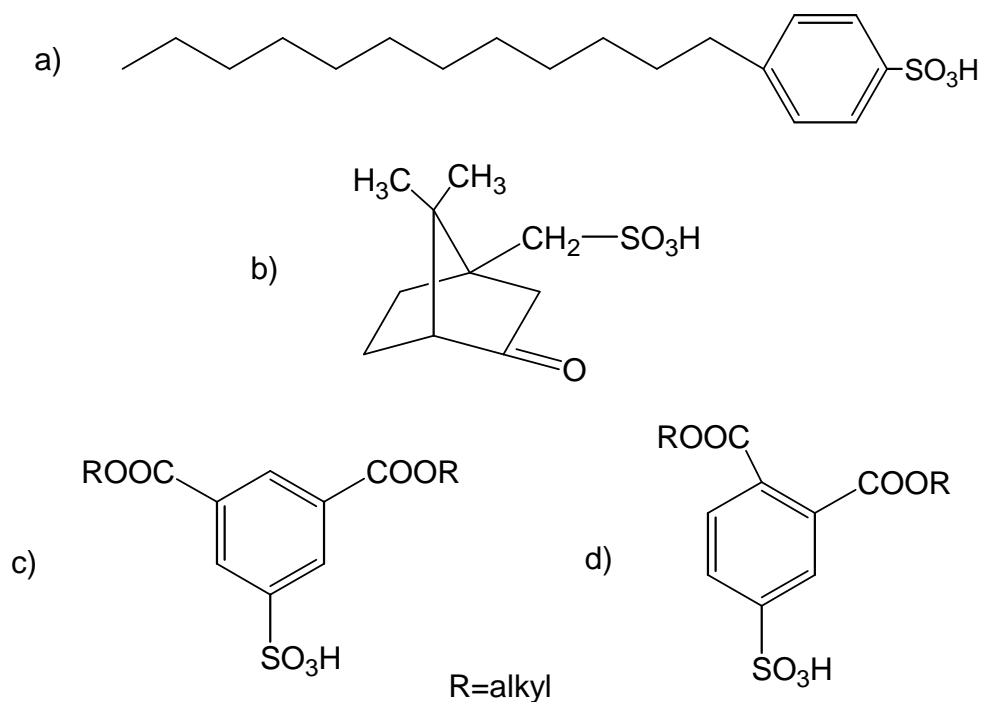

Fig. II.7.1 Selected sulfonic acids used for the acid-base doping of PANI

Adams and co-workers studied the properties of polyaniline doped with 2-acrylamid-2-methyl-1-propanesulfonic acid [68]. PANI doped with this acid is soluble in dichloroacetic acid (DCAA). Films cast from DCAA solution shows high conductivity of 210 S/cm, but also exhibit poor mechanical properties.

A promising group of polyaniline “plastdopants” possessing $-\text{SO}_3\text{H}$ functional group was developed recently. Diesters of 4-sulphophthalic acid and 5-sulphophthalic acid (fig.II.7.1c,d) [7,11] are derivatives of diesters of phthalic acid widely used as industrial plasticisers. It was proven that not only solubility and conductivity (as in the case of DBSA), but also mechanical properties of polyaniline doped with these acids would be improved. Indeed, this is a case. Polyaniline doped with “plastdopants” is soluble in typical organic solvents as well as in dichloroacetic acid (DCAA). Films cast from DCAA solutions exhibit both good mechanic properties (elongation at break often exceeds 40%) and the metallic-type conductivity over a wide temperature range.

Diesters of phosphoric acid (fig. II.7.2 a,b) are another family of polyaniline dopants improving polymer properties [6,69]. Diesters are formally derivatives of triesters of phosphoric acid, which are efficient industrial plasticisers for commercial, non-conductive polymers.

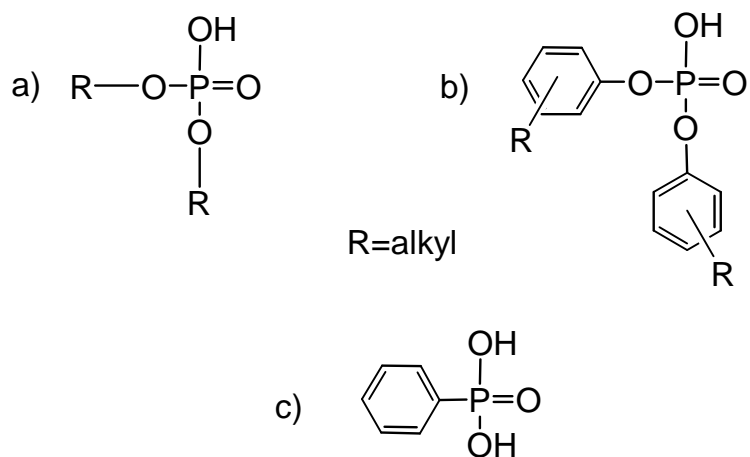

Fig.II.7.2 Diesters of phosphoric acid (a,b) and phenylphosphonic acid (c) used for the acid-base doping of PANI

Polyaniline doped with such compounds is not only soluble in common solvents such as chlorobenzene or THF, but also can be processed using thermal methods [70]. In the latter case, dopants containing phenyl rings (fig.II.7.2b) are preferred, because of their higher thermal stability (up to 200 °C). Conductivity of polyaniline protonated with this type of acids reaches 10^2 S/cm (for PANI/DPHP_(0,5) where DPHP denotes diphenyl phosphate). PANI doped with diesters is suitable for the preparation of conductive blends with polymers such as polystyrene, poly(methyl methacrylate) and others.

Phenylphosphonic acid, (fig. II.7.2c) was also investigated as a dopant of PANI [8].

As it was mentioned earlier, polyaniline can be considered also as a Lewis base. Recently, it was evidenced that PANI can be doped (complexed) with Lewis acids [13,14]. As it was presented in chapter II.6, structures of Lewis acid doped PANI differ significantly from those of protonated polyaniline. Consequently, these complexes exhibit different chemical and spectroscopic properties. Lewis acids used for PANI doping were metal halides such as SnCl₄, AlCl₃, and FeCl₃. Some of them readily hydrolyse, so it is necessary to provide strictly anhydrous conditions in all manipulations. It was shown that the complexes of emeraldine and emeraldine hydrochloride with Lewis acids are soluble in nitromethane and acetonitrile i.e. solvents which dissolve neither PANI base nor PANI doped with Brønsted acids.

The preparation of polyaniline doped with BF₃ was reported by Kumar et al.[15] However, these authors did not presented conclusive results proving the existence of PANI/BF₃ complex.

Pseudoprotonation is a doping reaction similar to the protonation process; it also bases on alkaline properties of PANI. In the reaction with salts such as LiCl, LiClO₄, LiBF₄, (CH₃)⁺(CH₃SO₄)⁻ [71,72,73] similar structure as for protonated emeraldine is formed, but instead of protons, corresponding cations couple with imine groups. Charge carriers are much more localised than in protonated polyaniline, thus conductivity of these systems vary between 10^{-7} S/cm for LiCl, $\sim 10^{-3}$ S/cm for LiBF₄ and LiClO₄, $\sim 10^{-2}$ S/cm for (CH₃)⁺(CH₃SO₄)⁻.

II.7.2 Properties of PANI doped with (\pm)-camphor-10-sulfonic acid

As it was mentioned in chapter II.1, emeraldine in its base form has the band-gap equal to 3,8 eV. Its electrical conductivity is in the range of 10^{-7} S/cm. Upon doping the conductivity increases several orders of magnitude. The doping induces some changes in its band gap [74]. New polaronic levels between HOMO (π) and LUMO (π^*) are created upon doping. UV-Vis-NIR spectroscopy is a convenient method to examine changes in the polyaniline π -electrons transitions [66].

In the UV-Vis spectrum of a thin solid film of PANI base two bands can be distinguished at 330 nm and 640 nm. The former is usually ascribed to the $\pi \rightarrow \pi^*$ transition in the aromatic ring, whereas the latter is associated with the presence of the quinoid in emeraldine form and is attributed to an excitonic transition between the quinoid ring and benzoid rings.

Protonation significantly changes the UV-Vis-NIR spectra of emeraldine introducing, among others, new features in the NIR part of the spectrum. In addition, the solution spectra become solvent dependent and the solid state ones depends on the medium used for casting. PANI doped with (\pm)-camphor-10-sulfonic acid is an instructive example of this behaviour.

The spectra registered for doped polymer films cast from CHCl₃ or m-cresol have different shapes as it is shown in fig.II.7.3. In the UV-Vis-NIR spectrum of PANI/(CSA)_{0,5}/CHCl₃ a sharp intense peak at 780 nm, and a second one at 380 nm can be observed. In fact, the peak at 380 nm is a superposition of two peaks at 340 nm and 440 nm. The band at 340 nm is attributed to $\pi \rightarrow \pi^*$ transition in the aromatic ring, which is red shifted comparing to that measured for PANI base. This shift can be considered as a result of doping. The peaks at 380 nm and 780 nm are related to the transition to energy levels characteristic of localised polarons. It may be concluded that in case of the polymer cast from chloroform the supramolecular structure does not allow the delocalisation of polarons.

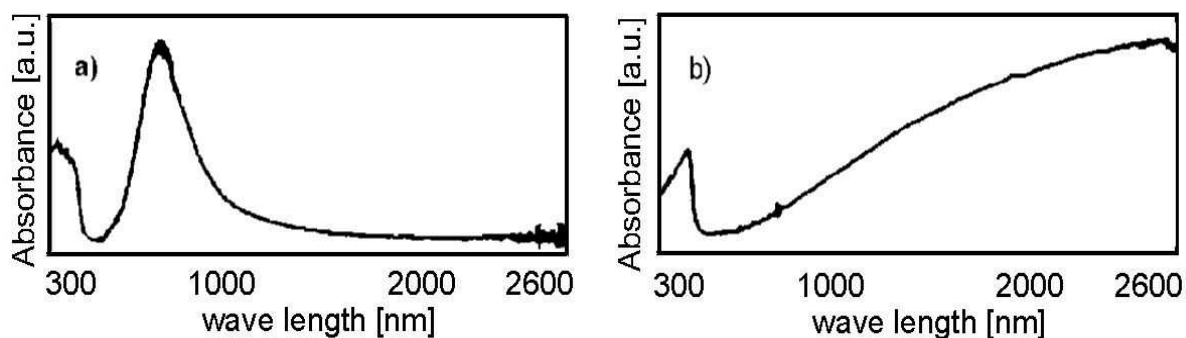

Fig. II.7.3 UV-Vis-NIR spectra of PANI/(CSA)_{0.5} films cast from: a) chloroform, b) *m*-cresol [66]

To the contrary, the use of solvents such as *m*-cresol, which strongly interact with the polymer chain (for example via hydrogen bonding) leads, after casting, to a more regular supramolecular organisation, which facilitates polaron delocalisation. This is manifested by significant changes in the UV-Vis-NIR spectrum as well as in the increase of the conductivity. The spectrum of PANI/(CSA)_{0.5} film cast from *m*-cresol (fig. II.7.3b) shows a sharp non-symmetric peak at 450 nm. Monotonic increase of absorbance above 1000 nm is characteristic of inner transitions in delocalised polaron bands and confirm the “metallic” character of this form of polyaniline.

It was found that not only phenols [66], but also fluorinated alcohols such as 1,1,1,3,3,3 – hexafluoro –2- propanol (HFIP) [75] are solvents suitable for casting of “metallic” polyaniline films. PANI/CSA_{0.5} cast from HFIP exhibit metallic-type conductivity exceeding 200 S/cm. Contrary to the case of phenols, total evaporation of the solvent is feasible in this case.

II.7.3 Polyaniline chain functionalisation

Functionalisation of the polymer chain – in view of tuning the polymer properties - the method giving good results in the case of conductive polymers such as poly(thiophene) and poly(*p*-phenylene vinylene), was also investigated in the case of polyaniline. Substitution of the aromatic ring with alkyl or alkoxy substituent improves solubilisation of the polymer and extends the number of efficient PANI solvents. Unfortunately, even small size substituents present in the aromatic ring significantly perturb the chain planarity causing an increase in the torsion angle between neighbouring aromatic rings. Conjugation of “twisted” polymer is diminished comparing to that of not functionalized one, which is manifested by lower conductivity of the doped samples. Moreover, as it can be expected, the conductivity decreases with increasing substituent bulkiness.

For polyaniline, poly(2-methylaniline)(P2EA) and polyanisidine (PANIZ) doped with HCl in the same conditions conductivity is 4,4 S/cm, 0,26 S/cm and 0,14 S/cm, respectively [76]. Very similar results were obtained by J.A. Conklin and co-workers for PANI and PANIZ [77]. HCl doped poly(2-ethyl)aniline exhibit poor electrical properties with conductivity 10^{-3} S/cm [78], but relatively high conductivities (1 S/cm) for P2EA doped with HCl were also reported [50].

Increase of the conductivity is also possible when functionalised monomer as anisidine is co-polymerised with aniline, but this is a compromise – solubility is lower than in the case of functionalised anilines obtained by homopolymerisation [77].

Another important process converting polyaniline to a processible form is “self-doping” – the method combining doping and chain functionalization. In this strategy polyaniline rings are functionalized with strong acid groups (as for example $-\text{SO}_3\text{H}$). Such groups are capable of nitrogen atoms protonation in the same chain. The main feature of the obtained product is improved stability in alkaline solutions; moreover, such polyaniline is water-soluble. Conductivities of self-doped polyanilines reach 1 S/cm, when acid group is coupled to already prepared polyaniline. In the case of co-polymerisation of sulfoaniline with aniline, conductivities are not higher than 10^{-2} S/cm [79].

II.7.4 Spectroscopic properties of polyaniline doped with Lewis acids

Spectroscopic properties of PANI doped with Lewis acids (L.A.) differ from those of protonated polyaniline. It is caused by a different nature of chemical interactions between L.A. dopant and the polymer.

The UV-Vis-NIR spectrum of film of emeraldine doped with SnCl_4 film is shown in fig. II.7.4. High absorption peak with a maximum in the vicinity of 1250 nm is characteristic for polyaniline doped with Lewis acids such as SnCl_4 , FeCl_3 , GaCl_3 or AlCl_3 . These systems undergo fast decomposition when exposed to the traces of moisture. Hydrochloric acid – which is one of the products of this decomposition – can protonate polyaniline. As a consequence, the spectrum (fig. II.7.4b) of PANI doped with L.A. and exposed to air quickly changes and becomes characteristic of PANI doped with a Brönsted acid.

Conductivity measurements are consistent with the UV-Vis-NIR spectroscopy. The electrical conductivity of Lewis acid doped PANI does not exceed 10^{-2} S/cm, but upon exposure to humid air rapidly increases and finally reaches value typical of PANI/ $\text{HCl}_{(0,5)}$.

High absorbance values in the NIR part of selected Lewis and Brönsted acid doped polyaniline and its derivatives is of practical interest since materials absorbing in this

spectral range are rare. On the other hand, low environmental stability of PANI doped with Lewis acids diminishes in principle its practical applications. Development of stable Lewis acid polyaniline dopants seems to be interesting way for improving properties of PANI/LA complexes.

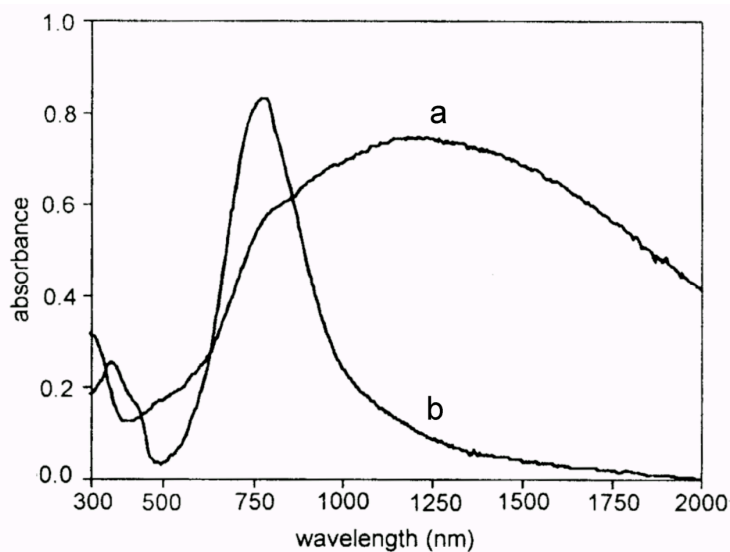

Fig.II.7.4 The UV-Vis-NIR spectra of PANI/(SnCl₄)_{1,0}/(CH₃NO₂)_{1,0} cast from nitromethane: a) freshly prepared film, b) film exposed to the water vapours for 10 min.[13]

The protonation influences vibrational properties of the polyaniline chain [80,81]. One can postulate that similar effect takes place in the case of doping PANI with Lewis acids. Indeed, in the case of the infrared spectrum of Lewis acid doped polyaniline noticeable changes are observed comparing to undoped emeraldine [82]. Similarly to protonated PANI, both C-C quinoid and benzoid bands are shifted bathochromically (1565 cm⁻¹ and 1484 cm⁻¹, respectively). C-H bending vibration, which is sensitive to doping process, is also redshifted (1146 cm⁻¹) and increases its intensity, which also is diagnostic of the doping process. The shifts are smaller than those observed in the spectrum of protonated PANI. This suggests weaker polymer-dopant interactions. An important evidence of the doping is observed in the low energy IR region. The band at 800 cm⁻¹ in L.A. doped PANI is attributed to the out of plane deformation of para-substituted polyaniline ring. The analogous band in undoped PANI appears at 826 cm⁻¹. Moreover, in the spectra registered for samples showing the deficit of the dopant, both peaks are visible, this suggests that the doping process is not homogenous. Additionally, upon Lewis acid doping, a new band appears near 1600 cm⁻¹. This signal is observed neither in polyaniline base nor in protonated PANI.

Two investigated systems - PANI/SnCl₄ and PANI/FeCl₃ - are unique from the spectroscopic point of view. Both of them contain nuclei (⁵⁷Fe and ¹¹⁹Sn) for which nuclear gamma resonance is observed. For this reason PANI doped with FeCl₃ or SnCl₄ can be studied using Mössbauer effect spectroscopy. Two parameters of the Mössbauer spectrum: isomer shift (I.S.) and quadrupole splitting (Q.S.) provide precise and unambiguous information about the oxidation state and coordination sphere of the investigated nucleus.

Mössbauer spectroscopy results obtained for polyaniline as well as for polyaniline hydrochloride doped with SnCl₄ are summarised in [13]. Both spectra of PANI/(SnCl₄)_{1,0}/(CH₃NO₂)_{1,0} and PANI/(HCl)_{0,45}/(SnCl₄)_{0,55}/(CH₃NO₂)_{0,55} represent similar pattern – one symmetrically broadened peak. Isomer shift of this band (0,43 mm/s for doped PANI and 0,49 mm/s for doped PANI/(HCl)_{0,5}) is characteristic of hexacoordinated Sn⁴⁺ nuclei. Since quadrupole interactions are not resolved for these complexes, the calculation based on broadening of the line allow determining the value of the Q.S. (0,49 mm/s in both cases).

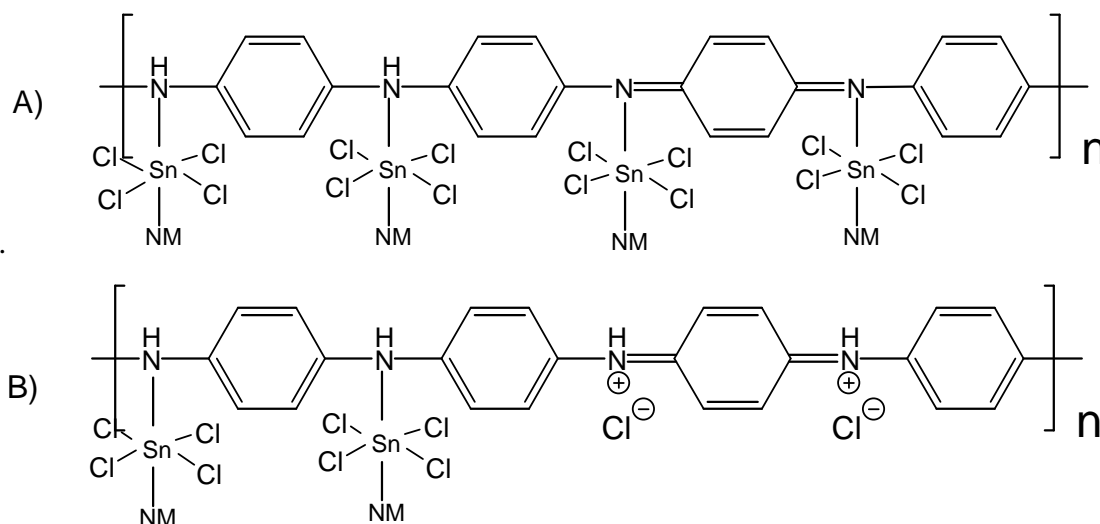

Fig.II.7.5 Emeraldine base (A), and emeraldine hydrochloride (B) doped with SnCl₄ in nitromethane (NM)

This value of Q.S. is an evidence for non-symmetrical environment around tin nuclei. No signal for tetracoordinated, uncomplexed SnCl₄ was detected. This observation combined with the ratio of N:Sn equal to 1 seems to indicate the existence of the complex presented in fig.II.7.5. Each tin nucleus is surrounded by four chlorine ligands, one complexing nitrogen atom of PANI, and one molecule of the solvent i.e. nitromethane.

The existence of two non-equivalent complexing sites is also evidenced by ⁵⁷Fe Mössbauer spectroscopy of FeCl₃ doped PANI [14].

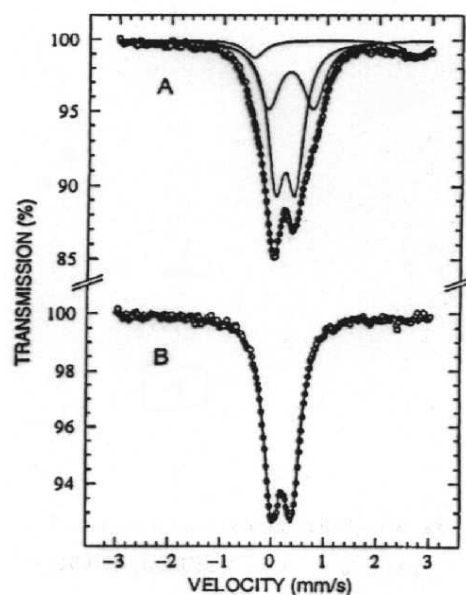

Fig.II.7.6 Mössbauer spectra registered at 77 K of a) emeraldine base doped with $FeCl_3$ (1:1) in nitromethane b) emeraldine hydrochloride doped with $FeCl_3$ (1:0,5) in nitromethane [14]

The Mössbauer spectra registered at 77 K for PANI base and PANI(HCl)_{0,5} complexed with $FeCl_3$ are presented in fig.II.7.6. The spectrum of polyaniline base doped with $FeCl_3$ i.e. PANI/($FeCl_3$)_{1,0}/(CH_3NO_2)_{1,0} can be deconvoluted into two principal doublets characteristic of Fe^{3+} compounds (92% of total peaks area), and a third doublet (8%) which is typical of Fe^{2+} impurities.

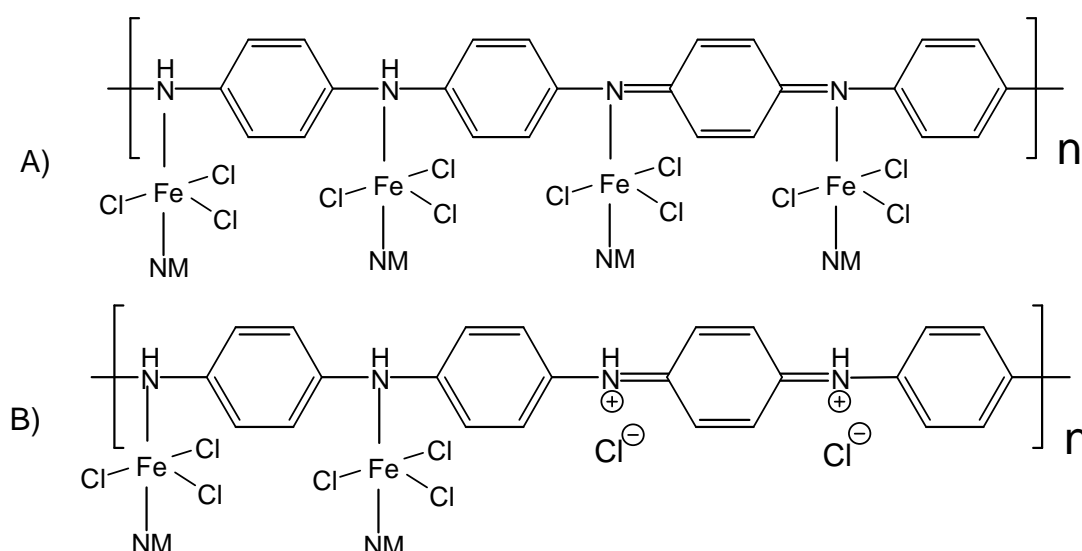

Fig. II.7.7 Emeraldine base (A), and emeraldine hydrochloride (B) doped with $FeCl_3$ in nitromethane (NM)

Two main signals have been attributed to FeCl_3 complexing both imine and amine sites. Mössbauer parameters unequivocally prove that FeCl_3 is complexed. Isomer shifts are characteristic of tetraordinated or pentacoordinated Fe^{3+} species. Quadrupole splitting suggests non-symmetrical environment around iron nucleus in both cases, thus structures analogous to that of polyaniline doped with SnCl_4 have been proposed (fig. II.7.7). These findings are consistent with the results of the chemical analyses, which indicate the incorporation of the solvent molecule into the PANI-Lewis acid complex.

The spectrum of $\text{PANI}/(\text{HCl})_{0,5}/(\text{FeCl}_3)_{0,5}/(\text{CH}_3\text{NO}_2)_{0,5}$ is different. Its interpretation given in [14] is as follows. Since in this case the imine sites are blocked by strong protonic acid (HCl), doping with FeCl_3 (weaker acid) is possible only on the amine sites. As a consequence, in the Mössbauer spectrum only one doublet can be distinguished with Mössbauer parameters identical to those found for the “internal” doublet in the PANI/ FeCl_3 spectrum.

The interpretation of the Mössbauer effect data, presented in the first two papers devoted to Lewis acid doping of polyaniline [13,14] although plausible, cannot easily explain the formation of radical cations (polarons) in the doped polymer chain. Taking into account complementary ^{57}Fe Mössbauer spectroscopy data obtained for FeCl_3 doped polymers and ^{27}Al NMR results for AlCl_3 doped ones, obtained in the course of this research, we are tempted to propose an alternative interpretation described in details in chapters IV.2 and IV.5.

III EXPERIMENTAL

III.1 EXPERIMENTAL TECHNIQUES

III.1.1 High and low temperatures

Oil baths were used for temperatures up to 250 °C.

Ice with sodium chloride was used as a cooling agent when temperatures not lower than $\sim -7^{\circ}\text{C}$ were required. Liquid nitrogen was used to reach -196°C . Liquid helium (-269°C) was complied with some experiments.

III.1.2 Primary and high vacuum equipment

Oil rotary pump Unitra BL-27 connected to a liquid nitrogen trap using a rubber hose was used in some applications. In this case, pressures were measured using a mercury manometer.

In the majority of experiments a specially designed high vacuum system was used which consisted of three units: pumping unit, glass high vacuum line and appropriate high vacuum apparatus and glassware which could be attached to the vacuum line, if necessary.

a) Pumping unit

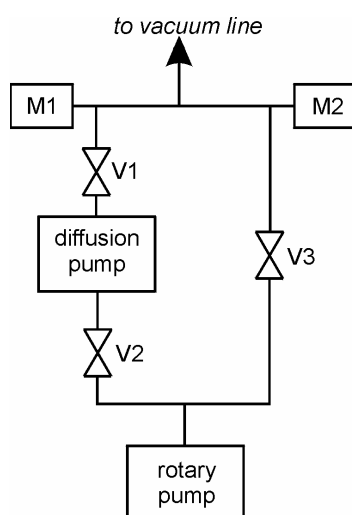

Fig.III.1.1 Scheme of pumping unit were M1, M2 – gauges; V1, V2, V3 – electropneumatic valves

The high vacuum pumping unit (ZAP, Bolesławiec, Poland) was composed of two pumps (fig. III.1.1): a rotary pump Jambol D30A, which allowed to obtain pressure down to 10^{-3} hPa, and the oil diffusion pump M-300 which evacuated the system down to $5 \cdot 10^{-5}$ hPa. Two gauges were used in the vacuum system: M1 – a resistance vacuum meter working in the range ~ 760 hPa (atmospheric pressure) $\div 5 \cdot 10^{-4}$ hPa, and M2 – an ionisation vacuum meter working in the range $5 \cdot 10^{-4}$ hPa $\div 10^{-6}$ hPa.

b) Vacuum line

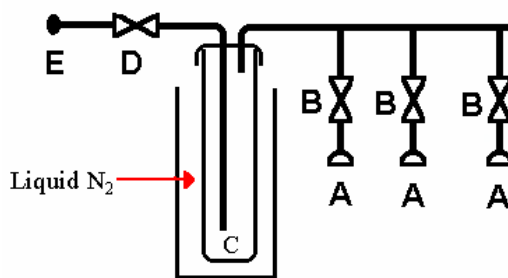

Fig. III.1.2 Vacuum line equipped with a main valve (D) connecting the line with the pumping unit (E), a liquid nitrogen trap (C), three high vacuum stopcocks (B) and ball joints (A)

The vacuum line was constructed of Pyrex glass (fig.III.1.2). Glass valves and Contess joints were lubricated with Apiezon N vacuum grease.

c) Vacuum glassware

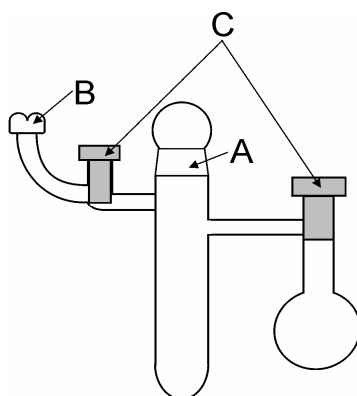

Fig. III.1.3 Vacuum reactor: A – joint, B - spherical joint, C - Rotaflo stopcocks

All vacuum apparatus were constructed of Pyrex glass and equipped with Rotaflo high-vacuum stopcocks and ground joints. A typical reactor used for the doping experiments is shown in fig.III.1.3 Bulbs for drying solvents and sample's storage tubes were also used.

III.1.3 Dry Box

BS 531 Dry Box produced by JACOMEX, Livry-Gorgan, France was available. It was connected to a JACOMEX catalyst unit that constantly purified argon in the box from water and oxygen traces. The levels of water and oxygen were constantly measured, and typical values were 2~3 ppm for O₂ and 3~4 ppm for H₂O.

The Dry Box was used for manipulations with non-volatile, air-sensitive compounds, i.e. for the transfer of samples into Mössbauer spectroscopy sample holders, NMR and EPR capillaries, sealing tubes for elemental analyses, etc.

III.1.4 Glove Bag

A glove bag was used when it was inconvenient or impossible to use the Dry Box. Glove bags were produced by Sekuroka. A oxygen and water-free argon supplied by Multax was applied. After placing all equipment inside the glove bag it was flushed 3 times and finally, filled with argon.

III.1.5 Elemental Analyses

Elemental analyses were performed by Service Central d'Analyse à CNRS, 69390 Vernaison, France, and by Laboratory of Elemental Analyses at Warsaw University of Technology, Warsaw, Poland.

- Carbon, hydrogen and nitrogen were determined by combustion analysis;
- Fluorine was analysed using a F⁻ ion selective electrode after combustion and solubilisation;
- Quantity of chlorine was determined by mercurimetry after platinum catalysed combustion in oxygen atmosphere;
- Iron was determined by ICP-AES(*) method after mineralisation in HClO₄ –HNO₃ solution;
- Aluminium was determined (after mineralisation in HClO₄ –HNO₃ solution) by atomic absorption spectroscopy using GBC Avanta PM apparatus.

Air-sensitive samples were stored and transported in vacuum – sealed tubes.

III.1.6 Spectroscopic Equipment

a) UV-Vis-NIR spectroscopy

The measurements in the spectroscopic range 190 nm ÷ 2500 nm were made using Perkin-Elmer Lambda 900, and Varian CARY 2315 spectrometers in Hellma Quartz 1 mm cuvetes with Teflon corks. In all cases appropriate solvent was used as a reference. Air-sensitive solutions were poured into the cuvetes in the Dry Box or Glove Bag. UV-Vis-NIR spectra in the spectral range of 200 nm -1100 nm were measured on a Perkin-Elmer Lambda 2 spectrometer.

b) Infrared spectroscopy

Infrared absorption spectra ($400\text{ cm}^{-1} \div 4000\text{ cm}^{-1}$) were registered on Fourier transformation spectrometers: BIO-RAD FTS-165, or Perkin-Elmer Paragon 500, using the KBr pressed pellets technique. In the case of air sensitive compounds a droplet of solution containing the substance studied was dropped on one of the pressed pure KBr pellet surfaces. Then, another KBr pressed pellet was put on the top of the first one and their contacts was sealed with vacuum grease. The described system efficiently isolated the studied substance from the influence of air.

c) Electron Paramagnetic Resonance (EPR) spectroscopy

EPR spectra were recorded at room temperature on Bruker ER 200X spectrometer (9 GHz) with 100 kHz modulation. Polymer samples were measured in thin quartz tubes equipped with a valve and filled with argon.

d) Nuclear Magnetic Resonance (NMR) spectroscopy

The ^{27}Al magnetic resonance studies of the liquid samples were carried out on Varian Mercury 400 in $\text{CD}_3\text{NO}_2/\text{CH}_3\text{NO}_2$ and $\text{CD}_2\text{Cl}_2/\text{CH}_2\text{Cl}_2$ solutions. Spectra were registered at room temperature.

e) Mössbauer effect spectroscopy

^{57}Fe Mössbauer effect spectra were recorded on a homemade spectrometer constructed by Jean-Louis Oddou and Claudine Jeandey (CEA Grenoble) according to rules described elsewhere [83].

Cobalt 57 dispersed in Rhodium matrix was used as the source. In this research all spectra are presented as recorded (with source as the reference), but peaks parameters are calculated in reference to metallic iron. The spectra were registered at different

* ICP-AES – Inductively Coupled Plasma – Atomic Emission Spectrometry

temperatures: usually at 4K and 77K. Polyamide-6 capsules with fine thread were applied as sample holders.

f) Mass spectroscopy

Mass spectra were acquired on a Thermofinnigan spectrometer, equipped with an electrospray source and a LCQ-ion trap. When ionisation from the solid state was required spectrometer ADM Intecta AMD 604 was used.

g) X-ray investigations

The powder samples were measured by use of Philips X-ray wide-angle diffractometer at the room temperature. It was equipped with a copper X-ray tube wavelength and nickel filter. Diffracted intensity was collected for 2θ angle from 2° to 40° with the step $0,05^\circ$.

III.1.7 Other techniques

a) Centrifuge

In some cases, when separation of precipitate was particularly difficult a centrifuge JANETZKI K24 equipped with refrigerated rotor was used.

b) Viscosity measurements

An automatic Ostwald viscosimeter AMTEC coupled with a registering unit was used to perform the viscosity measurements. Concentration of the investigated solutions was 0,184 g of polymer on 100 ml of solution. (1g of polymer /1000g of solution). Concentrated sulfuric acid (96%) was used as a solvent.

III.2 PREPARATION OF REAGENTS

III.2.1 Purification of reagents and solvents

Chemicals used in the course of this research are described below:

- 1) Aluminium (III) chloride, anhydrous, AlCl_3 (Aldrich) was vacuum dried and stored under Argon,
- 2) Aniline, $\text{C}_6\text{H}_5\text{NH}_2$, (POCh) was purified by double distillation under vacuum and stored in a refrigerator,
- 3) Ammonia, NH_3 , (POCh), 25% was diluted to corresponding concentrations,

- 4) Ammonium persulfate, $\text{NH}_4\text{S}_2\text{O}_8$, (Aldrich) was stored in a refrigerator (-4°C) and used as supplied,
- 5) Benzophenone (POCh) was used as supplied,
- 6) Calcium chloride, CaCl_2 , anhydrous, granulated, (Ubichem, Aldrich) was used as supplied,
- 7) Chloroform, CHCl_3 (POCh), was dried with anhydrous calcium chloride (CaCl_2) for 48 hours. Solvent was then decanted and distilled under an Argon flow,
- 8) Deuterated nitromethane CD_3NO_2 (Aldrich) was used as supplied,
- 9) Iron (III) chloride anhydrous, FeCl_3 (Fluka) was used as supplied,
- 10) Iron (III) chloride hexahydrate, $\text{FeCl}_3 \cdot 6\text{H}_2\text{O}$ (Aldrich) was used as supplied
- 11) o-(2-ethylaniline), C_8H_{10} (Aldrich) was purified by distillation under vacuum and stored in a refrigerator,
- 12) 1,1,1,5,5,5-hexafluoro-2,4-pentanedione (hexafluoroacetylacetone), $\text{C}_5\text{H}_2\text{F}_6\text{O}_2$ (Aldrich) was used as supplied. Product was opened and stored in a Dry Box.
Caution: Hexafluoroacetylacetone is toxic and corrosive liquid, so extreme care is required during handling,
- 13) Hydrochloric acid, HCl , 36% (POCh) was used as supplied,
- 14) Methanol, (CH_3OH), (POCh) was used as supplied,
- 15) 2-Methoxyaniline, anisidine, $\text{C}_7\text{H}_9\text{NO}$ (Aldrich) was purified by distillation under vacuum and stored in a refrigerator,
- 16) Methylene chloride, CH_2Cl_2 (POCh) was dried over molecular sieves type 4A,
- 17) N-methyl pyrrolidinone, NMP (BASF) was used as supplied,
- 18) N-phenyl-1,4 phenylene diamine hydrochloride (Aldrich) was used as supplied,
- 19) Nitromethane, CH_3NO_2 (Fluka) was dried with granulated anhydrous calcium chloride (CaCl_2) and distilled in a vacuum line. In some spectroscopic measurements CH_3NO_2 absolute, stored over molecular sieves (Fluka) was used as supplied,
- 20) Sodium, Na, (POCh) was stored in decaline,
- 21) Sodium Chloride, NaCl (POCh), was used as supplied,
- 22) Sulfuric acid, H_2SO_4 , 96% was used as supplied,
- 23) Toluene, $\text{C}_6\text{H}_5\text{CH}_3$ (POCh), was dried by refluxing under dry Argon over metallic sodium and benzophenone for at least 5 hours, and distilled,
- 24) Tris(acetylacetonato) aluminum(III) (Aldrich) was used as supplied,
- 25) Tris(acetylacetonato) iron(III) (Aldrich) was used as supplied.

III.2.2 Dopant synthesis

Derivatives of tris(acetylacetonato)iron(III) and tris(acetylacetonato) aluminium(III) were synthesised for doping purposes.

a) Preparation of chlorobis(acetylacetonato)iron(III)

FeCl(acac)₂ was synthesised according to ref. [84] using the redistribution reaction (eq.III.1)

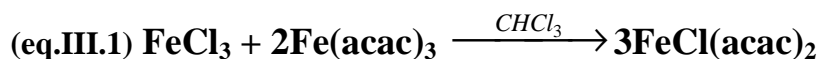

Anhydrous iron (III) chloride (1,165 g; 0,0072 mol) was dissolved in anhydrous CHCl₃ (25 ml) and mixed with Fe(acac)₃ (5,065 g; 0,0144 mol) dissolved also in anhydrous CHCl₃ (35 ml). The solution was heated (70 °C) in a spherical bulb under argon flow. After 6 hours the bulb was cooled and solvent was removed on a rotary evaporator. Subsequently, the dark red precipitate was dissolved in dry toluene, then filtrated on a closed hot (75 °C) Schott funnel under argon flow. The recrystallised product was dried under primary vacuum for 15 hours.

Results of the elemental analysis are presented in table 3.2.1.

	%C	%H	%Cl
found	41,16	4,44	11,73
calculated for C ₁₀ H ₁₄ ClFeO ₄	41,50	4,84	12,27

Table 3.2.1 Elemental analysis of chlorobis(acetylacetonato)iron(III)

Mass spectrum was registered for the product. Parent ion peaks are observed at m/e 289 and 291. Relative intensity (3:1) of these peaks is characteristic for the isotopic ratio ³⁵Cl : ³⁷Cl. It confirms presence of chlorine in the molecule. Peaks at m/e: 43, 155, 239, 254 are also characteristic for chlorobis(acetylacetonato)iron(III) decomposition.

Mössbauer spectroscopy experiment was performed for this sample. The obtained spectrum is composed of one doublet with no additional impurities (fig.III.1.4). Parameters of this doublet at 4K (isomer shift = 0,47 mm/s, quadrupole splitting = 1,02 mm/s) are in a very good agreement with published data (isomer shift = 0,48; quadrupole splitting = 1,02 mm/s at 4K) [84].

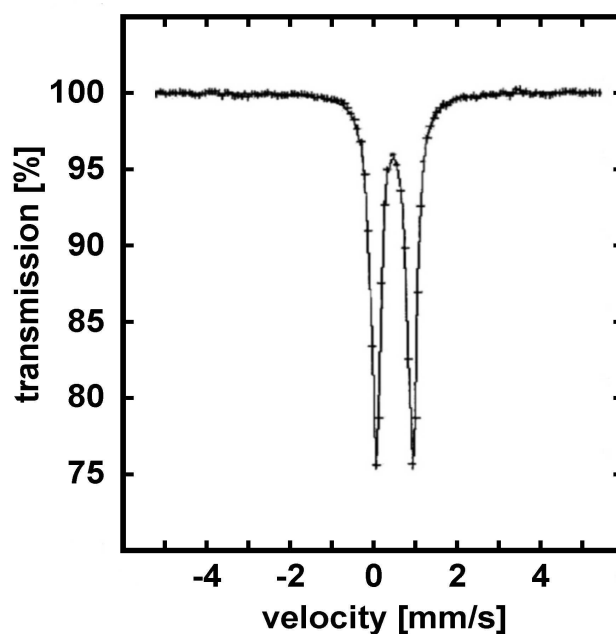
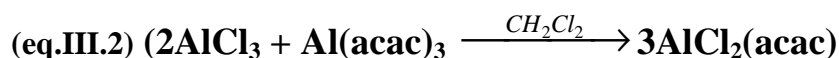

Fig. III.1.4 Mössbauer spectrum of chlorobis(acetylacetonato)iron(III) at 4K

b) Preparation of dichloro(acetylacetonato)aluminum(III)

$\text{AlCl}_2(\text{acac})$ was synthesised in following reaction (eq. III.2) [85].



4,00 g (0,030 mol) of aluminium (III) chloride was dissolved in 10 ml of dry CH_2Cl_2 and cooled down to 0 °C in a ice bath. Next, 4,86 g (0,015 mol) of tris(acetylacetonato)aluminium(III) was added. The temperature was raised to the room temperature while stirring, and synthesis was carried out for additional 8 hours. The product was filtered on a Schott funnel washed with CH_2Cl_2 and slowly dried on a vacuum line (mixture $\text{AlCl}_2(\text{acac}) - \text{CH}_2\text{Cl}_2$ is frothy).

^{27}Al NMR spectrum was registered for the product. In the spectrum five signals are present at: 102, 96, 87, 25 and 4 ppm. This result is consistent with published data [85]. According to the authors, two forms (monomeric and trimeric) of the dichloro(acetylacetonato)aluminum(III) are in equilibrium in the solution (eq. III.3).

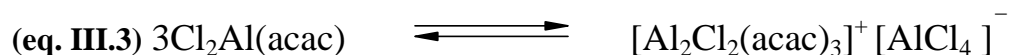

The signal at 102 ppm is characteristic of $[\text{AlCl}_4]^-$ anion. A broad signal at 87 ppm is in the region characteristic of a four coordinated aluminium species and is assigned to Al atom in the monomer. Aluminium five-coordinated atoms in $[\text{Al}_2\text{Cl}_2(\text{acac})_3]^+$ give broad signal at 25 ppm. A signal of a very small intensity at 3 ppm was also described, but the authors found it difficult to assign. Signal at 96 ppm was invisible in the published

spectrum, but intensity of the monomer signal was higher than in my research (equilibrium shifted to the monomeric form) and overlapping one signal by another was possible.

The obtained product was also characterised by FTIR spectroscopy. Diagnostic vibrational modes are presented in the table 3.2.2.

Wave number [cm ⁻¹]	Vibration type
1623	C=O stretch in a symmetric monomeric chelate ligand
1580	C=O stretch in an asymmetric trimeric chelate ligand
1539	C=C stretch

Table 3.2.2 IR vibrational modes of dichloro(acetylacetonato)aluminum(III)

III.2.3 Synthesis of polyanilines

The following polymers were routinely synthesized for the use in this research:

a) Polyaniline (emeraldine, PANI)

Polyaniline was synthesised according to the method of Cao et al. [86]. 10 ml (0,1097 mole) of aniline was dissolved in 150 ml of 1,5 M aqueous HCl solution in a 500 ml glass bulb (equipped with a thermometer and a dropping funnel) and cooled to 0 °C. The oxidizing agent was prepared by dissolving 12,5 g (0,0548 mole) of ammonium persulfate in 150 ml of 1,5 M HCl_{aq} solution. When the aniline solution was vigorously stirred, the (NH₄)₂S₂O₈ solution was added dropwise to aniline. Temperature was maintained at 0 °C, addition was performed during ca. 1 hour. After the oxidant was dropped in, the reaction mixture was left with constant stirring at 0 °C for additional three hours. Subsequently, the mixture was left to warm up to room temperature. Polyaniline was collected on a Schott funnel, washed with 1M HCl and distilled water, until the washing liquid became colourless. The obtained polyaniline hydrochloride was converted to the base form by stirring with 0,1 M aqueous NH₃ solution for 48 hours. It was followed by washing with water and methanol. Finally, the polymer was dried at room temperature on air and then dried under dynamic vacuum for 48 hours.

Peaks in infrared spectrum [cm⁻¹]: 1583, 1492, 1378, 1306, 1214, 1161, 1107, 829, 506

Inherent viscosity: 0,90 dl/g

b) Polyanisisidine (PANIZ)

Polyanisisidine was obtained by chemical oxidation of 2-metoxyaniline using $(\text{NH}_4)_2\text{S}_2\text{O}_8$ as oxidant in 1M HCl_{aq} solution. This method developed in the laboratory is in reality a modification of the method used for the preparation of PANI.

12.3 g (0,10 mol) of anisidine was dissolved in 200 ml of 1M HCl in a 500 ml glass bulb equipped with a thermometer and a dropping funnel. Anisidine solution was cooled to -5°C by immersing in ice/NaCl bath. Ammonium persulfate (28,50 g; 0,125 mol) was dissolved in 100 ml of 1M HCl. The oxidant was added dropwise to anisidine over the period of 1.5 hours. The temperature of polymerizing mixture was maintained at 0°C for additional 45 minutes. Then the water-ice bath was removed and the reaction was continued till the solution reached room temperature. The suspension was filtered and a dark green precipitate was collected. The precipitate was washed several times with 1M HCl until the filtrate became colourless.

Distilled water was then used to wash the product, then the suspension of the polymer was centrifuged at 10000 rpm for 10 minutes. These operations were repeated two times, and the polymer was deprotonated in 0.1M in aqueous solution of ammonium hydroxide for 48 hours. Finally, the polymer was filtered, washed with water and dried in air for 72 hours, then under dynamic vacuum for additional 20 hours.

Peaks in infrared spectrum [cm^{-1}]: 1594, 1511, 1409, 1324, 1259, 1215, 1167, 1122, 1029, 848, 807

Inherent viscosity: 0,34 dl/g

c) Poly(2-ethylaniline) (P2EA)

Poly(2-ethylaniline) was synthesized in the same way as polyanisisidine.

24.22 g (0,20 mol) of 2-ethylaniline was dissolved in 200 ml of 1M HCl. Ammonium persulfate (57,01 g; 0,25 mol) was dissolved in 200 ml of 1M HCl. All following procedure was exactly the same as in the case of PANIZ preparation. The precipitate obtained in this reaction had a purple-brownish colour. After washing with H_2O , there was no necessity to centrifuge the suspension. Poly(2-ethylaniline) was deprotonated as described above and vacuum dried for approximately 20 hours.

Peaks in infrared spectrum [cm^{-1}]: 1598, 1498, 1373, 1302, 1220, 1113, 1046, 891, 816

Inherent viscosity: 0,17 dl/g

III.2.4 Synthesis of aniline tetramer

Aniline tetramer was synthesised in the oxidative synthesis, which was a modification of the method described by W.J. Zhang et co-workers [58]. 0,025 mol (5,52 g) of N-phenyl-1,4 phenylenediamine hydrochloride was suspended in 450 ml of 1M HCl. Simultaneously, solution of iron chloride (III) hexahydrate (0,05 mol, 13,51g) was prepared using 120 ml of 0,1M HCl. Both solutions were cooled down to 0 °C. The bulb containing dianiline hydrochloride was placed in ice/NaCl bath and vigorously stirred. Subsequently, the oxidant was added in one go, and a green deposit appeared immediately. Reaction was carried out for additional sixty minutes. The precipitate was filtered, washed with copious amount of 0,1 M HCl and dried for 12 hours on air. The obtained tetramer hydrochloride was deprotonated by stirring with 0,1M NH₃ solution for 48 hours. Tetramer - 4EB - was washed several times with water and dried on air, and subsequently under high vacuum till the moment when constant mass was reached.

Peaks in infrared spectrum [cm⁻¹]: 1595, 1495, 1382, 1304, 1217, 1167, 841, 815, 743, 691

III.3 DOPING AND DEDOPING OF POLYANILINE AND ITS

DERIVATIVES

III.3.1 Doping procedures

Polyanilines in two forms were used for doping. First, emeraldines in the base state in which the doping reaction is possible on amine as well as on imine sites. Second, hydrochlorides of emeraldine, in which imine sites are selectively protonated [87,88] with hydrochloric acid. In this case, imine sites were blocked and doping could only occur on amine ones. Due to the fact that fraction of imine nitrogen in emeraldines may vary from 40% to 60 %, the protonation degree was determined (before doping with metal halides) by elemental analyses (Cl:N ratio).

In all doping procedures described in this work the doping reaction was carried out in vacuum/inert gas atmosphere using classical high-vacuum-line technique and a Dry Box. The apparatus used for doping is shown in figure III.1.3. Doping reaction was performed in a tube equipped with a joint. The bulb connected to the tube was used to store the dopant solution before the reaction; solvent and other substances (i.e. Fe(HFAA)₃) after the reaction.

a) Doping with AlCl₃

Anhydrous AlCl₃ (0,327 g, 0,00245 mol) was dried in high vacuum in 30 °C for 3 hours. Dry AlCl₃ was dissolved in dry nitromethane. Polyaniline (0,200 g, 0,0022 mol) was carefully vacuum-dried for 5 hours in 95 °C. Subsequently, the polymer was mixed with colourless dopant solution and stirred. Polyaniline complexation with Lewis acid was manifested by a green-blue coloration of the reaction medium. After 15 hours of doping the solvent was removed and deep-blue film of polyaniline was then dried for additional 5 hours.

The same procedure was applied for polyanisidine and poly(2-ethylaniline) using for example (0,265 g, 0,0022 mol) and (0,261 g, 0,0022 mol) of the polymer, respectively. Both doped polymers had also film-forming properties.

b) Doping with AlCl₂(acac)

AlCl₂(acac) (0,326 g, 0,0166 mol) was dried under high vacuum at room temperature for 3 hours. Next, it was dissolved in dry nitromethane. Polyanisidine (0,200 g, 0,00166 mol) was carefully dried in high vacuum for 5 hours in 95 °C. The polymer was mixed with colourless AlCl₂(acac)/CH₃NO₂ solution, and mixture changed color to deep-blue. After ca. 15 hours of stirring, the solvent was removed by vacuum transport and polymer was then dried for additional 5 hours.

The same procedure was used for the doping of poly(2-ethylaniline) (0,197 g, 0,00166 mol). Polyaniline was insoluble in AlCl₂(acac)/CH₃NO₂ solution.

c) Doping with FeCl₃

Anhydrous FeCl₃ (0,242 g, 0,00149 mol) was dried in high vacuum in 95 °C for 3 hours, next it was dissolved in dry nitromethane. Polyanisidine (0,200 g, 0,00166 mol) was carefully dried in high vacuum for 5 hours in 95 °C. Pale orange solution of FeCl₃ in nitromethane was mixed with PANIZ. The colour of the mixture immediately turned into green-blue. After 15 hours of doping colourless solvent was removed by vacuum transport and deep-blue film was obtained which was dried for additional 5 hours.

The same procedure was applied for poly(2-ethylaniline) and aniline tetramer using (0,196 g, 0,00166 mol) and (0,135 g, 0,00166 mol) of the material, respectively. P2EA doped with FeCl₃ has film-forming properties. 4EB doped with FeCl₃ was obtained as a powder.

d) Doping with FeCl₃ in the presence of hexafluoroacetylacetone

Amounts of the reactants as well as doping procedures were identical to that described for the doping of PANI with FeCl₃. However, triple molar excess of HFAA (with respect to FeCl₃) was added to the solution of PANI/FeCl₃/CH₃NO₂. Anhydrous FeCl₃ (0,323 g, 0,00198 mol) was dried in high vacuum in 95 °C for 3 hours, next it was dissolved in dry nitromethane. Polyaniline (0,200 g, 0,00221 mol) was carefully dried in high vacuum for 5 hours in 95 °C. Pale orange solution of FeCl₃ in nitromethane was mixed with PANI and stirred for 15 hours. Subsequently, hexafluoroacetylacetone was added (1,241 g, 0,005967 mol). After 15 hours of additional stirring the solvent was removed by vacuum transport. In all those reactions solutions separated after the reaction had orange colour. Drying of doped polymer in high vacuum caused the formation of opalescent film.

The solvent traces and volatile products of the doping reaction were collected in the liquid nitrogen trap when pumping. The trap was cleaned periodically; and procedure was continued till the stage, when no more orange color was observed in the trap. Typical pumping time was 50 hours.

e) Doping with FeCl(acac)₂

FeCl(acac)₂ (0,455 g, 0,0022 mol) was dried under high vacuum in room temperature for 5 hours. When dissolving dopant in dry CH₃NO₂, coloration of the solution turned in to deep brown.

Tests performed using UV-Vis spectroscopy showed that PANI - contrary to PANIZ and P2EA – does not interact with FeCl(acac)₂ and by consequence, is insoluble in reaction medium.

Polyanisidine (0,265 g, 0,0022 mol) was carefully vacuum-dried for 5 hours in 95 °C. During mixing dopant solution with the polymer, reaction medium become brownish. After ca. 15 hours of doping the colourless solvent was removed by vacuum transport and reddish powder was then dried for additional 5 hours.

The same procedure was performed for poly(2-ethylaniline)(0,261 g, 0,0022 mol), doped polymer has also form of reddish powder.

III.3.2 Dedoping procedures

To study the reversibility of the doping and to determine the chemical nature of the polymers the dedoping procedure has been performed. The samples taken out from the Dry Box were immediately mixed with 0.1 M HCl in a conical flask. The mixture was

stirred for 2 hours, then the solution was carefully decanted and the flask was poured with second portion of 0.1 HCl. This procedure was repeated two times. The washing with HCl was followed with water and finally the samples were transformed to its base form in 0,2 M aqueous NH_3 solution for 48 hours. Finally, polymer was filtered and dried under dynamic vacuum. The presence of iron and chlorine in the filtrate was tested using $\text{K}_4[\text{Fe}(\text{CN})_6]$ and AgNO_3 , respectively.

IV RESULTS AND DISCUSSION

IV.1 CHARACTERISATION OF PRISTINE POLYANILINES AND THEIR MODEL COMPOUND – TETRAMER OF ANILINE

IV.1.1 Introduction

Properties of polyanilines are strongly dependent on the conditions of the syntheses and subsequent purifications. Chain and supramolecular structures of the polymeric systems obtained from the same substrate and having the same empirical formulae can be distinctly different.

The molecular weight and the degree of crystallinity are important factors determining the behaviour of conjugated polymers after doping. Additionally, undoped polymer frequently serves as a reference for the doped system characterisation. Therefore, investigation of pristine polyanilines plays an important role in the understanding of the doping process.

Comparative characteristics of the polymers used in the course of this research (polyaniline, polyanisidine, poly(2-ethylaniline)) as well as aniline tetramer (4EB) are presented in this chapter.

IV.1.2 Elemental analyses

Elemental analyses were performed for all polymers in their base form as well as for the model compound i.e. tetraaniline. The obtained results are presented in table 4.1.1.

The calculations of the theoretical quantities of the elements in the polymers studied are based on the “average unit” approximation. Such unit is a derivative of the monomer used for the synthesis. Due to the fact that polyanilines are obtained in the emeraldine oxidation state, i.e. repeat unit is composed of three benzene rings and one quinoid ring, averaging correction is necessary. It causes that quantity of hydrogen atoms in a separate average unit is not an integral number. Moreover, in this model, polymer chains have infinite length i.e. existence of the end groups is neglected.

Differences between the experimental results and the calculated values are easier noticeable for P2EA than PANI and PANIZ. One can suggest a lower molecular weight in the P2EA case, so a higher number of end groups make the system less consistent with the model. The data published by Leclerc et al. [50] support this idea. Using GPC method,

these authors determined the molecular weight of poly(2-ethyl)aniline from chemical oxidative synthesis at 0 °C.

	%C	%H	%N
polyaniline - found	74,12	5,29	14,26
calculated for: $(C_6H_{4,5}N)_1(H_2O)_{0,38}$	73,99	5,40	14,37
polyanisidine - found	65,32	4,93	10,58
calculated for: $(C_7H_{6,5}NO)_1(H_2O)_{0,59}$	64,11	4,96	10,67
poly(2-ethylaniline) - found	77,21	6,73	10,26
calculated for: $(C_8H_{8,5}N)_1(H_2O)_{0,49}$	75,42	7,44	10,98
tetramer of aniline - found	77,58	5,58	14,88
calculated for: $(C_{24}H_{20}N_4)_1(H_2O)_{0,45}$	77,37	5,63	15,03

Table 4.1.1 Elemental analyses of polyaniline, polyanisidine, poly(2-ethylaniline) and tetramer of aniline in their base states

The obtained value – 5000 Da – is several times lower than that measured for polyaniline (80000 Da) synthesised in the same conditions. The same authors did not investigate polyanisidine, but the value of the molecular weight found by them for poly(2-methylaniline) is 7000 Da. This sequence of data shows a decrease of the chain length while increasing the bulkiness of the side group. This phenomenon is usually explained by steric hindrance effects when polymerising a monomer with more bulky substituents. In the light of the above results it is suggested that the molecular weight of polyanisidine should be intermediate between the values found for PANI and P2EA, because both volumes of methyl as well as methoxy groups are intermediate between those of hydrogen and the ethyl substituent.

Elemental analyses additionally show that all samples contain a certain amount of H₂O. This problem is discussed in the chapter devoted to X-ray investigations.

IV.1.3 Viscosity measurements

Viscosity measurements seem to be the most popular method allowing simple and reproducible estimation of polyanilines molecular weight. Exact viscosimetric assignment of the M_v is not possible, because Mark-Houwink coefficients have not been determined for these systems to date. Additionally, such coefficients would be different for polymers with various substituents, thus the results of viscosity measurements for different polymers may be interpreted only qualitatively.

Despite of these limitations, this method seems to be the best alternative when GPC method is not available. It can be also noted that GPC results for polyanilines may be given with important error. Polyaniline and polystyrene (used as a standard in GPC method) exist in two different conformations: rod-like and coil-like, respectively. This phenomenon causes different exclusion mechanisms and in consequence, affects the results of the analyses [89].

	Inherent viscosities [dl/g]
Polyaniline	0,900
Polyanisidine (T)	0,310
Polyanisidine (M)	0,344
Poly(2-ethylaniline) (T)	0,207
Poly(2-ethylaniline) (M)	0,174

Table 4.1.2 Results of viscosity measurements of polyaniline, polyanisidine and poly(2-ethylaniline), where T- test synthesis, M- main synthesis

The results of viscosity measurements presented in table 4.1.2 show that the value of the inherent viscosity (V_{ih}) is the lowest for P2EA – polymer with the most bulky side chains. The value of V_{ih} for polyaniline is the highest one. Consequently, for samples of polymer with metoxy side groups (PANIZ) the value of V_{ih} is located between those determined for PANI and P2EA. These results confirm the suggestion of a strong dependence of the polymer molecular weight on the size of its substituent.

As it was mentioned before, substituted polyanilines are less investigated as compared to PANI. The reproducibility of the oxidative polymerisation (described in experimental section) was additionally confirmed by the viscosity measurements of the polymer from two independent syntheses (test and main).

IV.1.4 X-ray investigations

X-ray diffraction is a very suitable tool to investigate the supramolecular organisation of the studied polymers. It also allows to determine their crystallinity index X_c :

$$X_c = \frac{\int I_{crystal}}{\int I_{crystal} + \int I_{amorphous}}$$

Where: $I_{crystal}$ - intensity scattered from crystalline regions,

$I_{amorphous}$ – intensity scattered from amorphous regions

Moreover, by appropriate use of computer-modelling methods it is possible to propose the structure of the crystalline areas.

Polyaniline has been examined using X-ray diffraction by several groups [90,91,92]. Two main forms of PANI base can be distinguished, so-called EB-1 and EB-2. EB-1 form is typical of PANI base, which originates directly from the synthesis. EB-2 is obtained from EB-1 via extraction using an appropriate solvent (NMP, TMU etc.) followed by casting of a freestanding film. Semi-crystalline form of PANI is known to contain a certain amount of water [93,94].

The role of water in the formation of crystalline domains in PANI base was recently investigated by Łużny et al. [95]. The authors found a clear correlation between the crystallinity index determined by X-ray diffraction and the content of water derived from the elemental analysis. More detailed calculations showed that the number of water molecules is close to the number of nitrogen atoms in the crystalline part of the sample. Computer simulations performed for the model where the ratio of nitrogen atoms to H₂O molecules is ~1; show a good agreement with the X-ray scattering experiments. This suggests that water is mainly entrapped in the polyaniline crystallites, thus water can be considered as an integral component of the polyaniline crystalline structure.

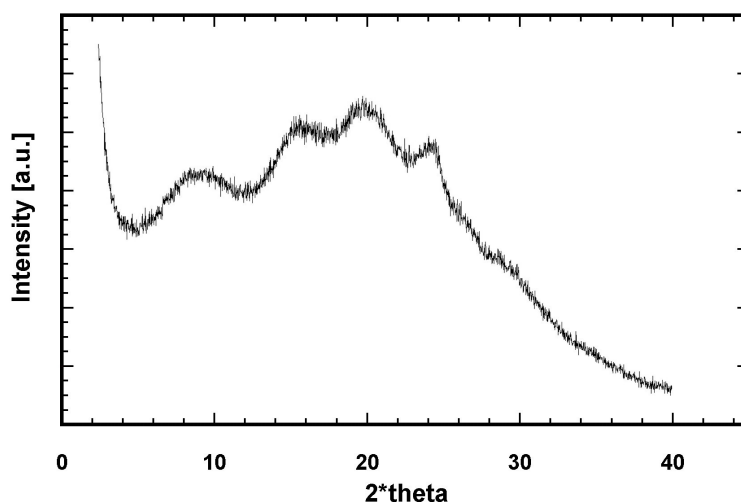

Fig. IV.1.1 Diffraction pattern of emeraldine base

The diffraction pattern of emeraldine base used in this research is presented in figure IV.1.1. In agreement with the expectations, it shows features characteristic of EB-1, i.e. four reflections at $2\Theta \sim 9, 15, 20, 24$. The crystallinity index (determined according to Hermans-Weidinger method) are collected in table 4.1.3, they are consistent with the “ α ” subtype as indicated in the literature [95]. Computer modelling calculations have also been carried out for poly(2-ethylaniline) and polyanisidine. In the latter case no systematic studies of the role of water in the formation of the crystalline domains have been reported to date. Calculations methodology can be divided into three steps:

- building of repeat unit
- construction of periodic box
- energy optimisation in forcefield using “conjugated gradient technique”

	crystallinity index X_c
Polyaniline	21 %
Polyanisidine	34 %
Poly(2-ethylaniline)	11 %

Table 4.1. Crystallinity index determined for selected polyanilines

Polyanisidine exhibit the highest crystallinity of all investigated polyanilines. Furthermore, this crystallinity can be correlated with the highest water content (see table 4.1.1). Based on the above-described findings the crystalline structure of PANIZ can be considered as similar to that of PANI.

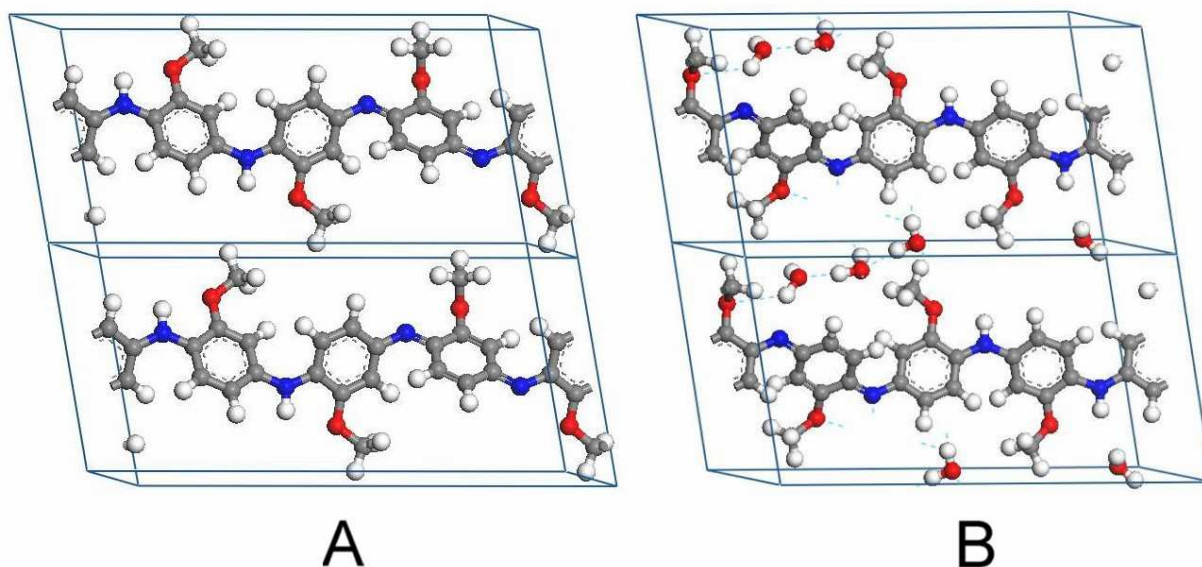

Fig. IV.1.2 Calculated structures of polyanisidine in a crystallite a) without H_2O b) containing H_2O molecules.

Theoretical diffraction patterns were calculated for conjectural structures of PANIZ without (fig. IV.1.2a) and with (fig. IV.1.2b) crystallisation water. The comparisons of these functions with the experimental curves are presented in figs. IV.1.3a and IV.1.3b. One can conclude with no ambiguity that the model of PANIZ with the crystallisation water is consistent with the results of the experiment. The assumed ratio of nitrogen atoms to H_2O molecules - similarly as in the model developed for PANI - is equal 1.

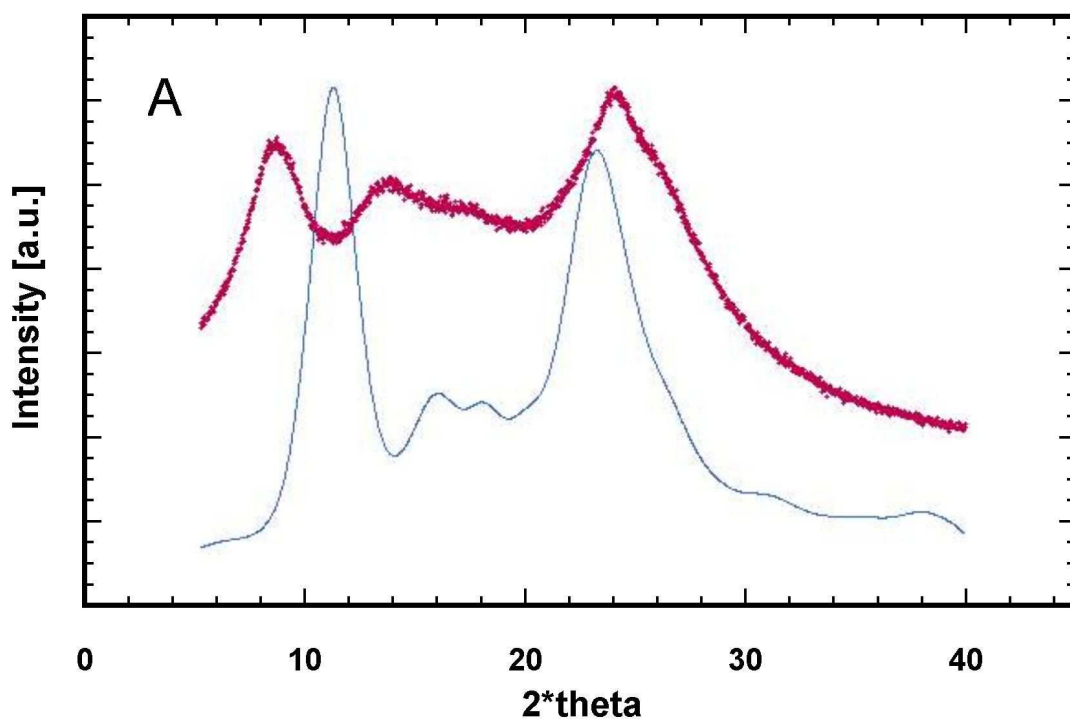

Fig. IV.1.3a Comparison of experimental pattern obtained for PANIZ (red line) and the theoretical results calculated for the model assuming no H_2O molecules (blue line)

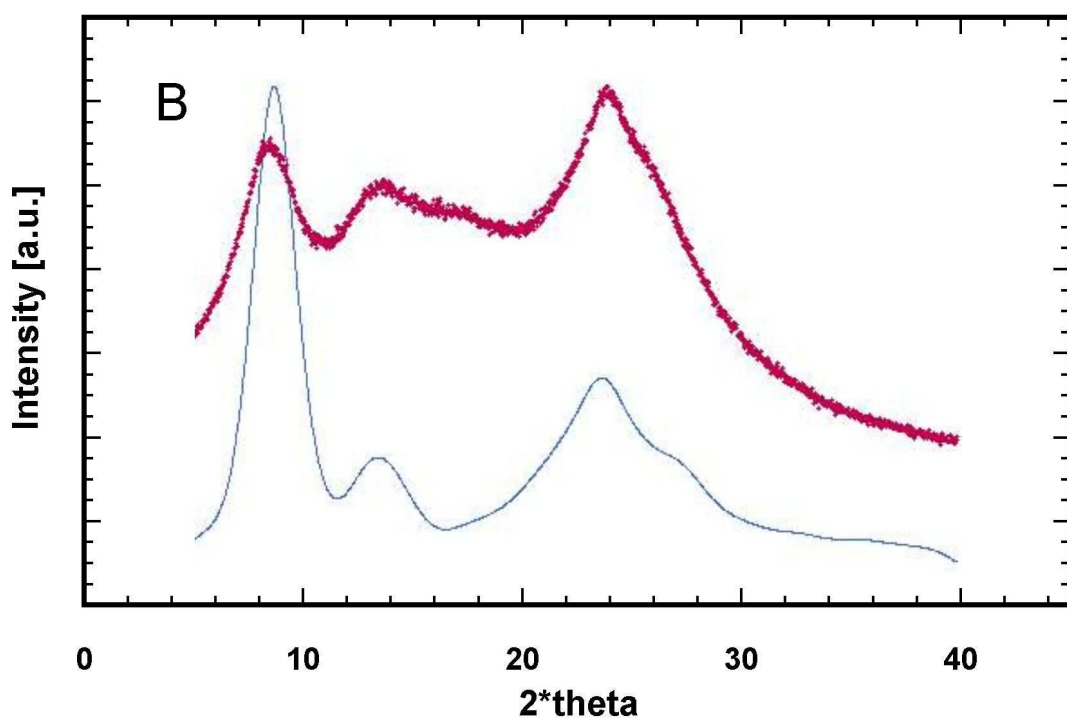

Fig. IV.1.3b Comparison of the experimental curve obtained for PANIZ (red line) and the theoretical results calculated for the model assuming one H_2O molecule per one nitrogen atom (blue line)

The combination of the parameters: crystallinity index – water content in the P2EA sample is analogous, i.e. the lowest value of the former parameter coexists with the lowest value of the latter. This suggests the analogous crystalline structure for this polymer.

In all the samples the quantity of H₂O is higher than that calculated for the model presented above. This strongly indicates that water is also present in the amorphous parts of the polymer, which is not taken into account in the presented model. It is known that samples stored in air adsorb a certain quantity of H₂O molecules, which can be removed during the drying process [96].

It should be underlined that the presence of H₂O in the crystalline parts of the polymer plays a crucial role in the polyanilines chemistry. It is caused mainly by the fact, that the removal of water from the crystallites - by means such as heating/high vacuum drying - is practically impossible with no polymer decomposition [96]. On the other hand, during polymer dissolution water is released and can take part in various chemical processes.

It is worth noting that in the X-ray spectra of doped polymers no crystalline part was detected. In such cases dopant can be considered as an impurity disturbing crystallisation process.

IV.1.5 UV-Vis-NIR studies

The spectra of the base form of PANI, PANIZ, P2EA and 4 EB dissolved in NMP are presented in fig. IV.1.4.

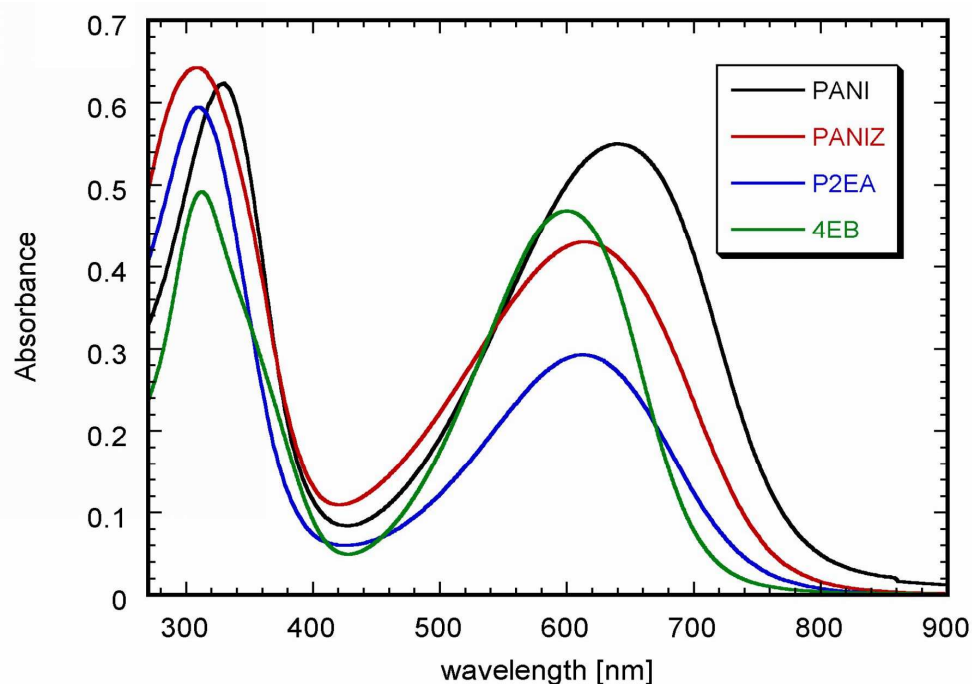

Fig. IV.1.4 The UV-Vis spectra of polyanilines and tetramer of aniline in NMP

In each case two peaks are present in the spectrum. The peak located near 300 nm is characteristic of the $\pi \rightarrow \pi^*$ transition in the benzenoid rings. The second peak has been attributed to an excitonic-type transition between the HOMO orbital of the benzenoid ring and LUMO orbital of the quinoid ring [97,98]. The peaks of both substituted polyanilines are shifted towards higher energies as compared to the case of polyaniline. Such shift is characteristic of systems with reduced conjugation. As expected the largest hypsochromic shift is observed for the tetramer (4EB). The presence of these two peaks unambiguously indicates that all compounds studied are in their semi-oxidised base form.

IV.1.6 IR studies

Infrared spectra for PANI, PANIZ, P2EA and 4EB are presented in figs. IV.1.5 and IV.1.6 whereas the attribution of the observed bands are indicated in tables 4.1.4 – 4.1.7.

The spectra exhibit similar features, the observed differences between them can be attributed to the presence of side groups attached to the aromatic rings.

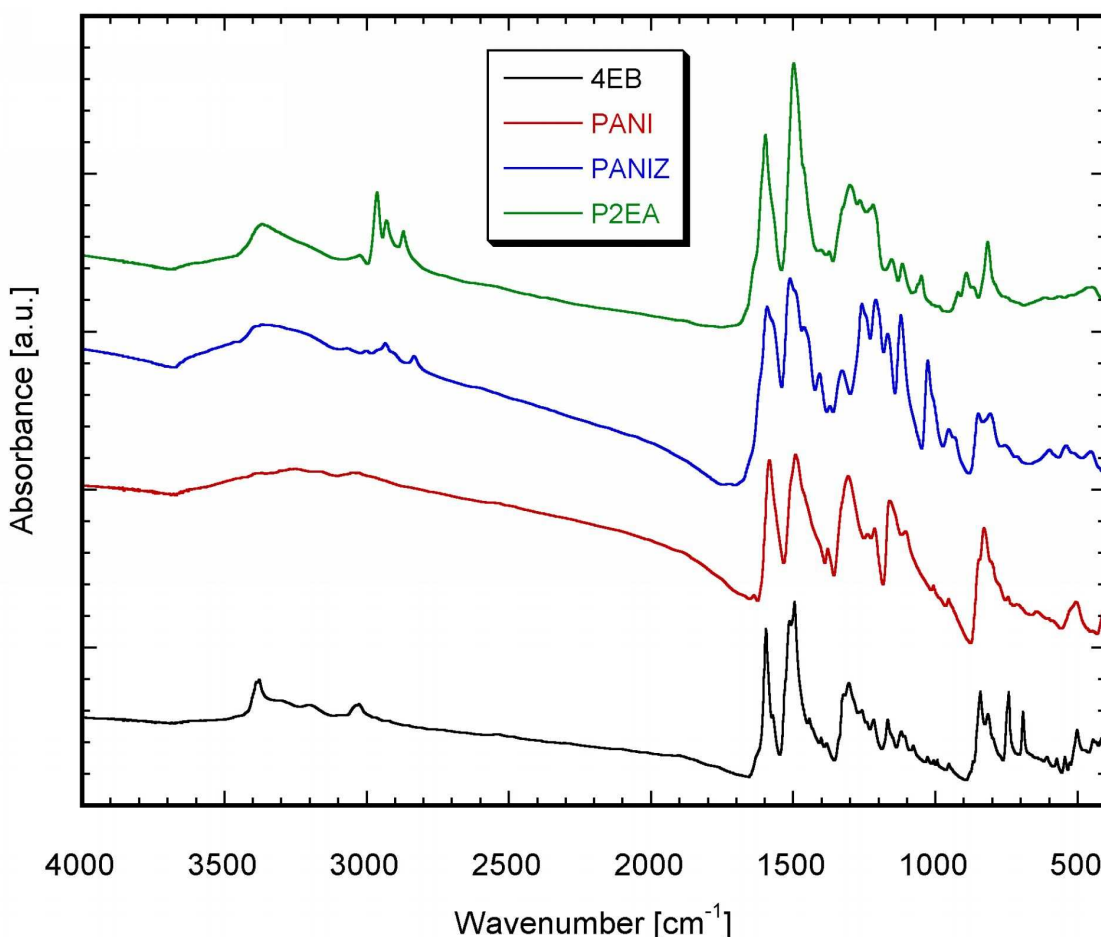

Fig. IV.1.5 IR spectra (4000 cm⁻¹ - 400 cm⁻¹) of polyaniline, polyanisidine, poly(2-ethylaniline) and the tetramer of aniline

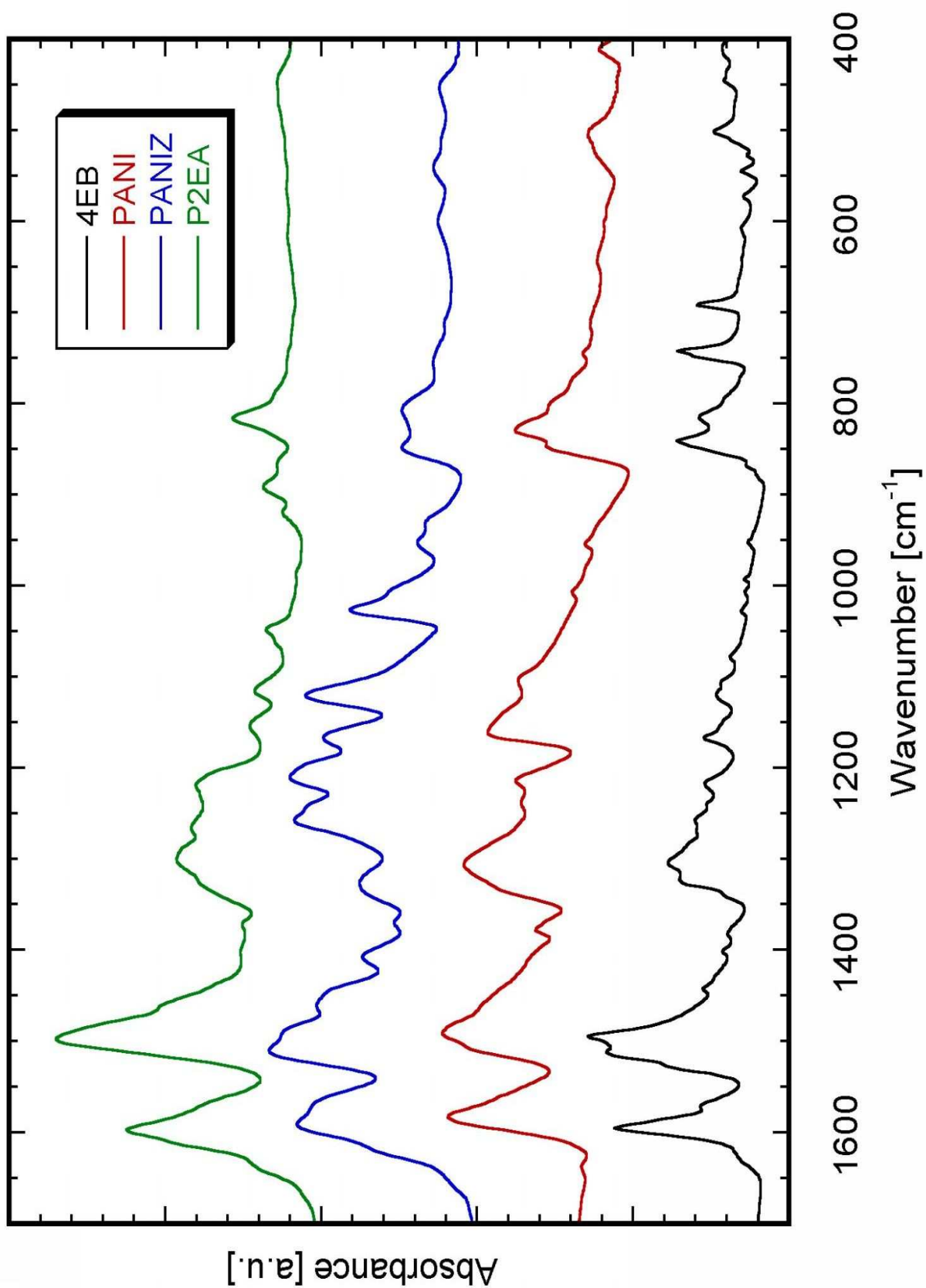

Fig. IV.1.6 IR spectra ($1700\text{ cm}^{-1} - 400\text{ cm}^{-1}$) of polyaniline, polyanisidine, poly(2-ethylaniline) and the tetramer of aniline

The broad band ca. 3500 cm^{-1} is assigned to the N-H stretching vibrations of amine groups. Peaks near 3000 cm^{-1} are attributed to the C-H stretching vibrations. Intensive bands close to 1600 cm^{-1} and near 1500 cm^{-1} are related to the carbon-carbon stretching vibrations in the quinoid and benzenoid rings, respectively. The latter contains some contribution from mixed C-H vibrations. The bands that appear only in the PANIZ spectrum at 1029 cm^{-1} and at 1259 cm^{-1} are ascribed to C-O vibrations of $\text{C}_{\text{Ar}}\text{-O-CH}_3$ groups.

Wave number [cm^{-1}]	Attribution
~3500	N-H stretch
~3000	C-H stretch
1583	C=C stretch in a quinoid ring
1492	C-C stretch in a benzenoid ring +C-H mixed vib.
1378	C-C stretch in a quinoid ring + C-H bending in a benzenoid ring
1306	C-H bending
1214	C-N stretch + C-H bending
1161	C-H bending
1107	Deformational of aromatic ring + C-H bending
829, 506	Deformational C-H (out of plane) of 1-4 disubstituted aromatic ring

Table 4.1.4 IR vibrational modes of polyaniline base

Bands characteristic of the out of plane vibrations of the aromatic ring appear below 1000 cm^{-1} . The subgroup of these peaks located within the area 910 cm^{-1} - 670 cm^{-1} allows the determination of the quantity and the position of the substituents in the aromatic ring [99].

Wave number [cm^{-1}]	Attribution
~3500	N-H stretch
~3000	C-H stretch
1594	C=C stretch in a quinoid ring
1511	C-C stretch in a benzenoid ring +C-H mixed vib.
1409	C-C stretch in a quinoid ring + C-H bending in a benzenoid ring
1324	C-H bending
1259	C-O stretch
1215	C-N stretch + C-H bending in a benzenoid ring
1167	C-H bending
1122	Deformational of aromatic ring + C-H bending
1029	C-O stretch
848, 807	Deformational C-H (out of plane) of aromatic ring

Table 4.1.5 IR vibrational modes of polyanisidine base

In the polyaniline spectrum one strong peak at 829 cm^{-1} is characteristic of a disubstituted ring. Additionally, two weak signals at 745 cm^{-1} and 713 cm^{-1} are typical of monosubstituted ring i.e. end groups of the PANI chain. In the spectrum of 4EB the peaks attributed to the disubstituted rings (841 cm^{-1} and 815 cm^{-1}) as well as to the monosubstituted ones (743 cm^{-1} and 691 cm^{-1}) are present. In the spectra of PANIZ and P2EA, the bands are typical of 1,2,4 trisubstituted aromatic rings. In both cases two bands are present: 848 cm^{-1} ; 807 cm^{-1} in the PANIZ spectrum and 891 cm^{-1} ; 816 cm^{-1} in the P2EA spectrum.

Wave number [cm^{-1}]	Attribution
~3500	N-H stretch
~3000	C-H stretch
1598	C=C stretch in a quinoid ring
1498	C-C stretch in a benzenoid ring +C-H mixed vib.
1373	C-C stretch in a benzenoid ring + C-H bending in a benzenoid ring
1302	C-H bending
1220	C-N stretch + C-H bending
1113	C-H bending
1046	Deformational of aromatic ring
891, 816	Deformational (out of plane) of aromatic ring

Table 4.1.6 IR vibrational modes of poly(2-ethylaniline) base

Wave number [cm^{-1}]	Attribution
~3500	N-H stretch
~3000	C-H stretch
1595	C=C stretch in a quinoid ring
1495	C-C stretch in a benzenoid ring +C-H mixed vib.
1382	C-C stretch in a quinoid ring + C-H bending in a benzenoid ring
1304	C-H bending
1217	C-N stretch + C-H bending
1167	C-H bending
841, 815	Deformational (out of plane) of disubstituted aromatic ring
743, 691	Deformational (out of plane) of monosubstituted aromatic ring

Table 4.1.7 IR vibrational modes of aniline tetramer base

It should be stated at the end, that the recorded IR spectra are fully consisted with the expected chemical constitution of all macromolecules (molecules) studied.

IV.2 DOPING OF POLYANILINES AND TETRAMER OF ANILINE WITH IRON (III) CHLORIDE

Iron (III) chloride was used for the doping of conductive polymers such as polyacetylene and poly(p-phenylene) in early 1980s [100,101]. It was found that during the doping a mixed red-ox and acid-base reaction occurs. In this process half of the FeCl_3 molecules act as an oxidizing agent, allowing the formation of polycarbonium cations, the second half of the ferric chloride molecules incorporate Cl^- anions forming FeCl_4^- moieties (fig.IV.2.1) [102]. The same type of process was reported for polypyrrole, polythiophene and its derivatives [103].

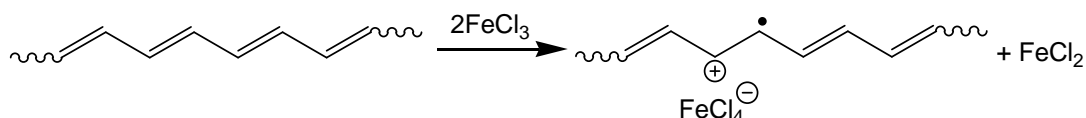

Fig. IV.2.1 Doping of polyacetylene with FeCl_3

Similar redox-type doping can also occur in leucoemeraldine – the most reduced form of polyaniline. Iron (III) chloride is not a sufficiently strong oxidant to oxidatively dope emeraldine – the semi-oxidised form of polyaniline, however taking into account its Lewis acidity one can postulate in this case a purely acid-base doping via a Lewis acid complexation reaction between the basic sites of the polymer and the dopant. This type of FeCl_3 doping for unsubstituted polyaniline has been reported for the first time by Genoud et al. [14]. FeCl_3 doped emeraldine exhibits distinctly different properties from those established for the protonated (Brönsted acid doped) and base (undoped) forms of this polymer. This subject requires further exploration because only few papers have been published on this matter [14,104,105] and no such doping has ever been performed for ring substituted polyanilines.

Comparative studies of FeCl_3 doped forms of emeraldine and its ring-substituted derivatives are difficult because of poor long-range order in these materials. Although the base forms of the polymers show some crystallinity (see: chapter IV.1.4), their Lewis acid complexation transforms them into amorphous systems. For this reason, diffraction techniques, probing the long-range order in polymers, are of limited use in this case. One can however take advantage of the fact that ^{57}Fe nuclei are Mössbauer effect active and perform Mössbauer spectroscopy investigations on solid films of doped polymers. Mössbauer effect is not dependent on the long range order and can provide important information concerning the closest coordination of the Mössbauer nucleus. In particular, careful analysis of two Mössbauer parameters – the isomer shift (I.S.) and the quadrupole

splitting (Q.S.) helps in unequivocal identification of the iron spin and oxidation states in the dopant-polymer complexes as well as provides data concerning the type and the symmetry of the closest coordination sphere in the iron complexes formed via the doping process. For this reason, Mössbauer effect spectroscopy constituted the principal experimental tool for studying the solid polymers in their FeCl_3 doped form, prepared in the course of this research.

Before discussing the nature of the solid state complexes between the dopant and the polymer it is instructive to describe the dopant-polymer interactions in the solution. These interactions determine the chemical and structural nature of the doped polymer whose freestanding films are obtained by casting from polymer/ FeCl_3 solutions in nitromethane.

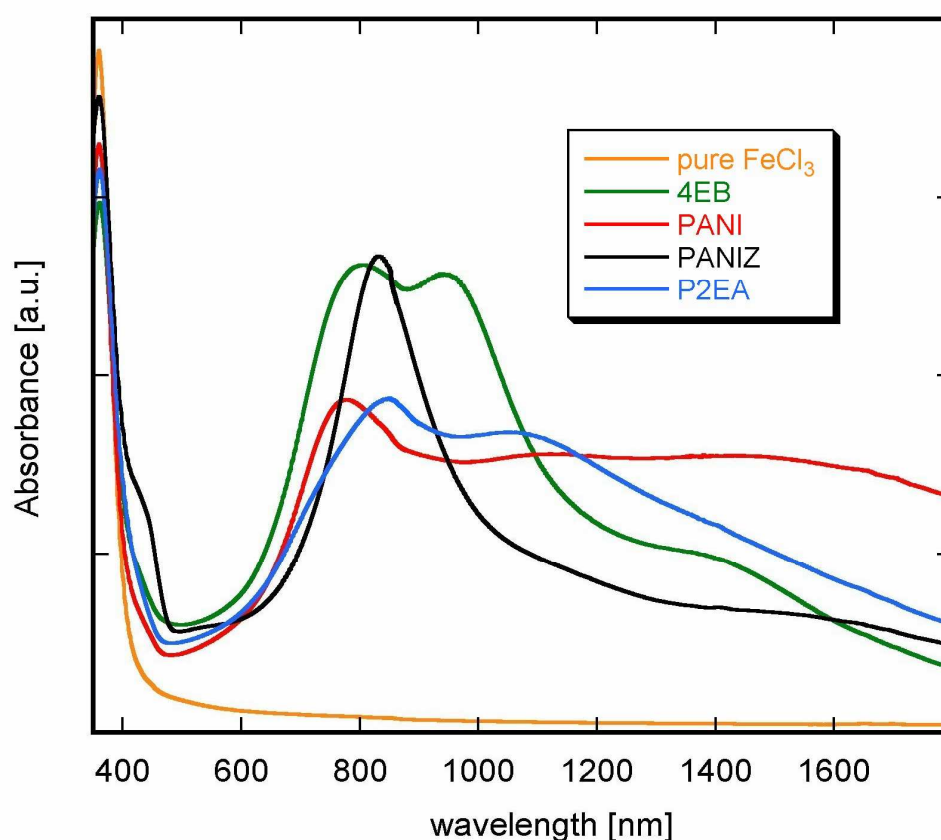
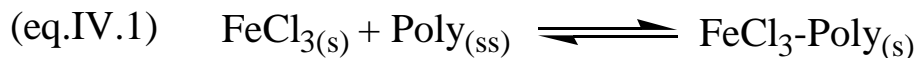

Fig. IV.2.2 UV-Vis-NIR spectra of the nitromethane solutions of pure FeCl_3 , polyaniline, polyanisidine, poly(2-ethyl)aniline and tetramer of aniline doped with FeCl_3 , ratio (1:1)

Mössbauer spectroscopy cannot be used in this case since it is a solid state probe. One can however take advantage of the fact that dopant – polymer interactions in the solutions strongly modify the UV-Vis-NIR spectra of both constituents of the complex. In fig. IV.2.2 solution spectra of all doped polymers studied are compared with that registered for FeCl_3 in the same solvent but without the presence of the interacting polymer.

First, we notice that in each case the band at 360 nm, which is characteristic of “free” FeCl₃, not interacting with the polymer is present in all spectra [106]. This means, that for the 1:1 FeCl₃/mer ratio used in all experiments, equilibrium between uncomplexed and complexed FeCl₃ is established (eq. IV.1).



(s) - solution (ss) - solid state

Second, in no spectrum presented in fig. IV.2.2 bands characteristic of the base form of the polymers studied are detected. Thus, the doping is in all cases effective, although only part of the doping agent is consumed in the doping reaction. The new spectral features in the range 700 – 1100 nm are typical of a doped polymer chain containing positive charge carriers. It is known that the near infrared (NIR) spectral features of doped polyanilines can be correlated with charge carrier delocalisation. A monotonic increase of the absorbance extending towards NIR (so called “NIR absorption tail”) is characteristic of delocalised charge carriers (polarons) whereas a localised absorption peak in the vicinity of 800 nm is typical of localised polarons [74]. A comparison of the spectra collected in fig. IV.2.2 clearly indicates that in the case of unsubstituted polyaniline, the charge delocalisation is the most pronounced. This can be explained by a more rectal and more planar conformation of unsubstituted polyaniline chains, as compared to PANIZ and P2EA ones. In P2EA chains the charge delocalisation is less pronounced because of the steric hindrance effects imposed by the ethyl substituents which lower the linearity and planarity of the chain. In fact, the NIR part of the spectrum consists, in this case, of two strongly overlapping broad bands which may imply two populations of polarons with different charge delocalisation length. The substituents in PANIZ can be treated not only as a steric hindrance source, but also as complexing sites of the following type: -N→Fe←O-, which additionally render the chain conformation out of planarity and linearity. Consequently, it limits the delocalisation of polarons. As expected, the low molecular model of polyaniline – 4EB – shows spectral features of localised polarons because the short length of the chain limits their delocalisation.

In the FTIR spectra registered for the doped polymers as well as for the tetramer, doping induced spectral changes are observed. In particular, an intensive peak near 1600 cm⁻¹ appears. Peaks of benzenoid and quinoid rings are red shifted by ca. 15 cm⁻¹, for example in polyaniline (fig. IV.2.3) they appear at 1561 cm⁻¹ and 1479 cm⁻¹. Mode at 1167 (treated as a diagnostic for doping) in PANI base is shifted to 1151 cm⁻¹. The peak at 816 cm⁻¹, attributed to deformational modes of the aromatic ring, is also shifted to lower

energies and is located at 801 cm^{-1} . Thus, the spectral features are typical of a charged polymer chain in the semi-quinone state.

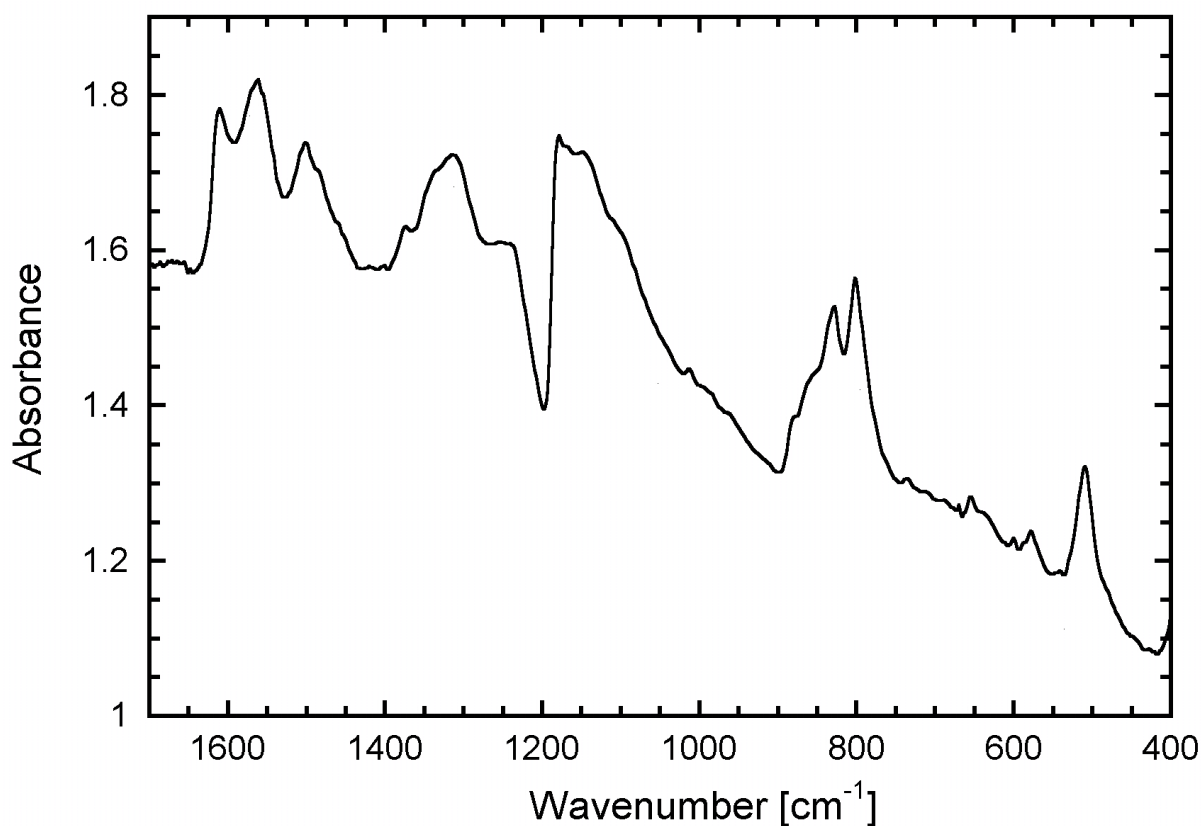
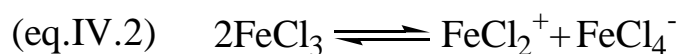

Fig. IV.2.3 IR spectrum (1700 cm^{-1} - 400 cm^{-1}) of polyaniline doped with FeCl_3 ; mer to dopant ratio (1:1)

The next question to be answered is how the positive charge carriers, whose presence is clearly manifested in the NIR and FTIR spectra of all compounds studied, are imposed on the polymer chain in a pure acid-base reaction? We are tempted to propose the following mechanism of the acid-base doping of polyaniline and its derivatives with FeCl_3 . In the first step self-dissociation of the doping agent occurs (eq. IV.2).



In the second step, both products of the self-dissociation reaction are incorporated into the polymer matrix as schematically depicted in fig. IV.2.4

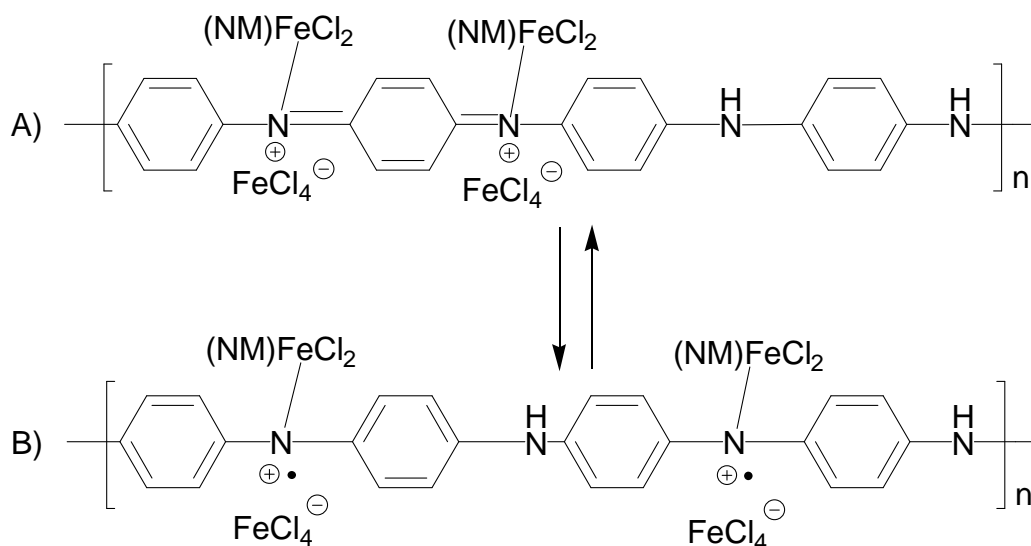

Fig. IV.2.4 Structure of emeraldine treated with iron chloride (III) in nitromethane

The reaction depicted in fig. IV.2.4. is formally analogous to the pseudo-protonation reaction sometimes used in the acid-base doping of polyaniline [107, 108]. Complexation of imine sites by FeCl₂⁺ leads to the bipolaron structure (fig. IV.2.4a), which upon the charge redistribution results in the formation of the polaron lattice (fig. IV.2.4b).

The next important problem is whether the equilibrium described by equation IV.2.1 is retained in the solid state, upon removal of the solvent. Mössbauer spectroscopy is well suited to address this problem. In fig. IV.2.5 Mössbauer spectra of the doped polymers and the tetramer are compared.

As it can be clearly seen, several common features can be distinguished in the recorded spectra. They can be deconvoluted into three doublets; two principal corresponding to high spin Fe(III) complexes and a third one characteristic of high spin Fe(II) species. The calculated Mössbauer parameters are collected in table 4.2.1.

First, it should be stated that no lines with Mössbauer parameters characteristic of uncomplexed FeCl₃ can be detected in any measured spectrum [109,110]. This finding indicates that the equilibrium described by eq. IV.2.1, which exist in the solution, is – upon solvent removal and solidification – totally shifted to the right. The two principal Fe(III) doublets must be ascribed to two structurally non-equivalent iron complexes existing in the doped polymer, consistent with the scheme depicted in fig. IV.2.4.

The doublet of lower quadrupole splitting value indicated in table 4.2.1 as “site 1” can unequivocally be ascribed to FeCl₄⁻ anions inserted between the polymer chains. The values of both Mössbauer parameters (I.S. and Q.S.) are very close those reported for FeCl₄⁻ inserted to several conjugated polymer matrices, via oxidative doping[102,103,111]. FeCl₄⁻ of strict T_d symmetry should exhibit Q.S.=0, its small, but measurable value reflects

the fact that the anion is slightly distorted in the polymer matrix and has the C_{3v} symmetry, although very close to the T_d one.

The second doublet of higher Q.S. value indicated in table 4.2.1. as “site 2” must therefore be ascribed to $FeCl_2^+$ forming a direct coordination bond with the polymer chain.

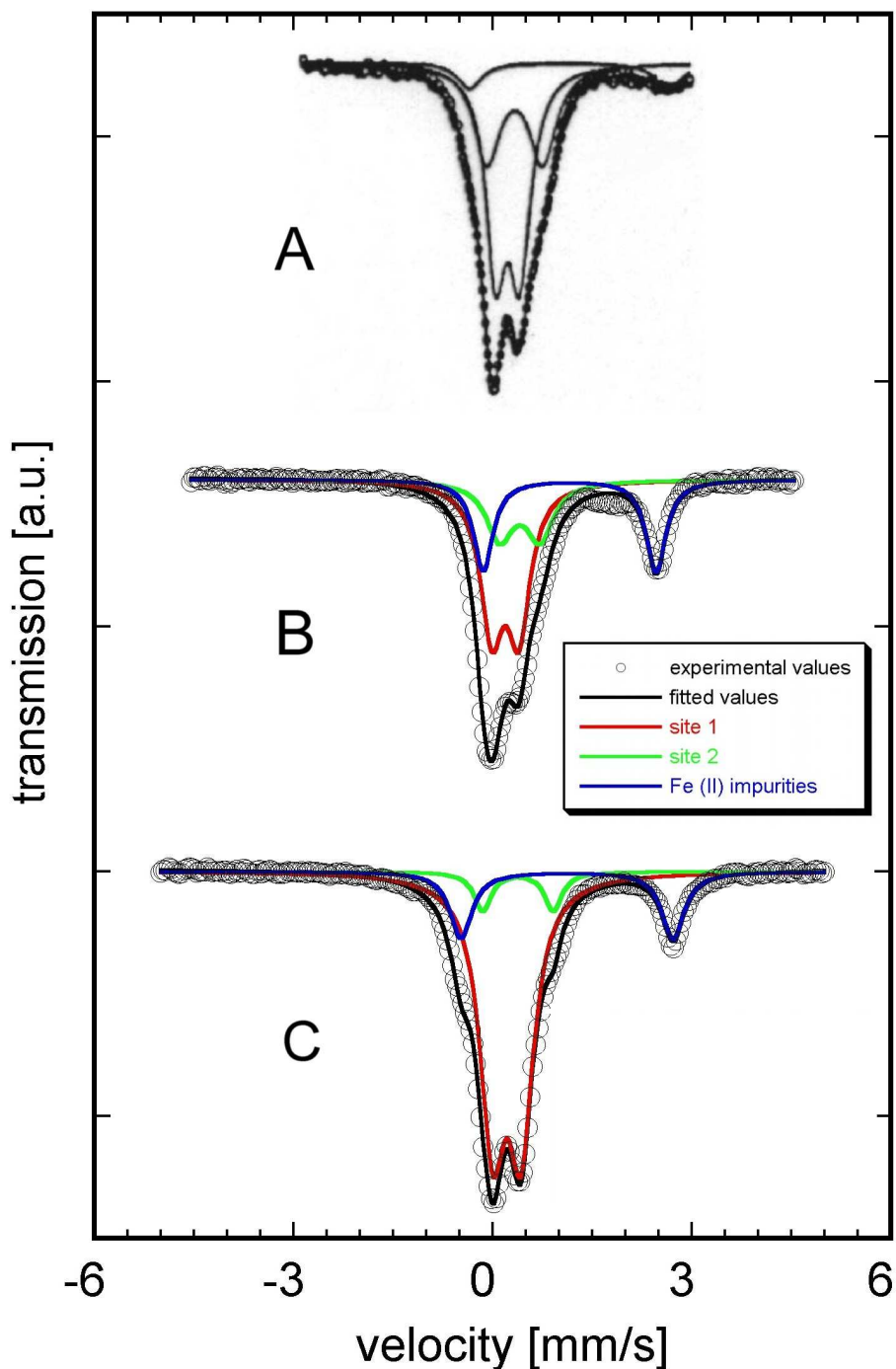

Fig. IV.2.5 Mössbauer spectra of complexes measured at 77K of following compounds doped with $FeCl_3$; mer to dopant ratio (1:1) A) polyaniline, B) poly(2-ethylaniline), C) tetramer of aniline

It should be noted here that Fe(III) practically does not form three-coordinated complexes [112], therefore it must be solvated with a solvent molecule retained in the solid matrix or coordinated to the adjacent polymer chain.

Sample	Mössbauer parameters	site 1	site 2	Fe ²⁺ signal
PANI/FeCl ₃ /CH ₃ NO ₂ [*]	I.S. [mm/s]	0,32	0,48	1,15
	Q.S. [mm/s]	0,38	0,89	3,10
	intensity [%]	43	45	12
P2EA/FeCl ₃ /CH ₃ NO ₂ ^{**}	I.S. [mm/s]	0,33	0,42	1,27
	Q.S. [mm/s]	0,36	0,87	2,59
	intensity [%]	53	24	23
4EB/ FeCl ₃ /CH ₃ NO ₂ ^{**}	I.S. [mm/s]	0,32	0,48	1,15
	Q.S. [mm/s]	0,39	0,98	2,93
	intensity [%]	74	8	18

Table 4.2.1 Mössbauer parameters of PANI, P2EA and 4EB doped with FeCl₃

^{*} registered at 4K, ^{**} registered at 77K

Elemental analysis of FeCl₃ complexed polyaniline shows an increased N/C and N/Fe ratio as compared to the formula depicted in fig. IV.2.4. This observation strongly indicates the solvation of the chain coordinated with Fe(III) atoms with nitromethane molecules [14]. Large Q.S. values obtained for “site 2” are consistent with the presented picture of non-equivalent ligands, which must introduce a large lattice term to the observed quadrupole splitting [113].

In doped conjugated polymers the spectra measured above 4 K are not quantitative because of an unusually low Mössbauer lattice temperature measured for these systems [14]. This may lead to a significant underestimation of the site 2 content. The same applies to the Fe(II) site detected in all samples whose presence must be in turn overestimated due to its significantly higher Mössbauer lattice temperature. It is obvious that Fe(II) cannot originate from the acid-base doping of polyaniline or any of its derivatives, but must be associated with a side redox reaction catalysed with a small quantities of water present in the crystalline parts of the base form of polyaniline. Polyaniline in perfectly semi-oxidised form should not be further oxidised by FeCl₃, but in the real polymer there exist less-oxidised segments which in the presence of minute amounts of H₂O can be oxidised with FeCl₃ to give hydrated FeCl₂ as the side product.

The above detailed interpretation is further corroborated by the doping of polyaniline hydrochloride i.e. the protonated form of polyaniline. In this case, upon the doping process, FeCl_3 is transformed into FeCl_4^- in an acid-base reaction with Cl^- anions as shown in fig. IV.2.6. No chain complexation with FeCl_2^+ takes place. As a result in the Mössbauer spectrum only one Fe(III) doublet is detected with Mössbauer parameters characteristic of FeCl_4^- [14,114].

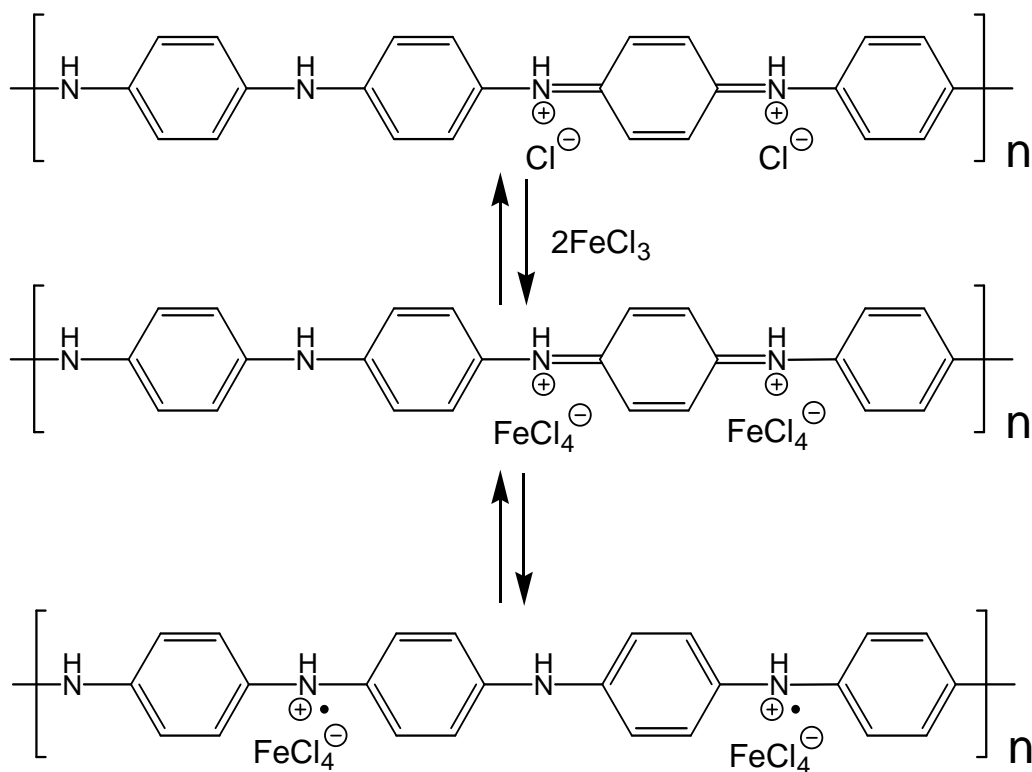

Fig. IV.2.6 Schematic representation of the reaction between FeCl_3 and polyaniline hydrochloride

In order to verify whether the conclusions derived from the Mössbauer spectroscopy results are consistent with the experimentally determined chemical compositions of doped polyanilines, we have performed elemental analysis of representative samples. In these studies the mer to dopant ratio was 1:0,9 to assure that no uncomplexed FeCl_3 is present in the sample. Results of the elemental analyses are presented in table 4.2.2.

The elemental analyses can be well fitted only assuming the presence of solvating nitromethane (NM) and irremovable water molecules originating from the crystalline parts of the base form the polymers, which were substrates in the doping reaction. It should be noted that the content of NM solvating molecules in PANIZ and P2EA is lower than the content of FeCl_2^+ cations indicating that the solvation is not the sole mechanism of the completing of the coordination polyhedron and the complexation by the adjacent polymer

chain (and in the case of PANIZ by oxygen atom in the substituent) must also be taken into consideration.

	%C	%H	%N	%Cl	%Fe
PANI doped with FeCl ₃ – found	28,89	2,48	8,51	31,36	17,19
calculated for (C ₆ H _{4,5} N) ₁ [(FeCl ₂ ⁺)(FeCl ₄ ⁻)] _{0,41} (CH ₃ NO ₂) _{0,54} (H ₂ O) _{0,20}	30,16	2,51	8,32	32,62	17,17
PANIZ doped with FeCl ₃ - found	30,33	2,89	6,40	30,94	16,09
calculated for (C ₇ H _{6,5} NO) ₁ [(FeCl ₂ ⁺)(FeCl ₄ ⁻)] _{0,42} (CH ₃ NO ₂) _{0,33} (H ₂ O) _{0,34}	30,33	2,92	6,41	30,80	16,20
P2EA doped with FeCl ₃ - found	33,09	3,39	6,05	30,55	15,68
calculated for (C ₈ H _{8,5} N) ₁ [(FeCl ₂ ⁺)(FeCl ₄ ⁻)] _{0,42} (CH ₃ NO ₂) _{0,30} (H ₂ O) _{0,11}	33,53	3,23	6,12	30,04	15,82

Table 4.2.2 Elemental analyses of PANI, PANIZ and P2EA doped with FeCl₃ in nitromethane

At the end, it should be noted that interpretation of the spectroscopic and analytical data presented in this section is significantly different than that proposed in [14] for FeCl₃ doped emeraldine. These authors proposed the formation of two types of complexes on imine and amine nitrogens without the creation of charged species. The principal weakness of this interpretation is the difficulty to justify the presence of positive charges in the doped polymer chains. These charges are detected not only by several complementary spectroscopic techniques, but also give rise to a several orders of magnitude higher value of the electronic conductivity of the sample ($\sigma = 10^{-2}$ S/cm) as compared to its undoped base form ($\sigma \sim 10^{-9}$ S/cm). In view of all new findings our interpretation of the experimental data seems to be more plausible.

IV.3 DOPING OF POLYANILINE AND ITS DERIVATIVES WITH IRON(III) CHLORIDE IN THE PRESENCE OF HEXAFLUOROACETYLACETONE

IV.3.1 Mixed doping of polyaniline with iron (III) chloride in the presence of hexafluoroacetylacetonone

The principal problems impeding the technological use of FeCl_3 doped polyaniline are: its limited environmental stability and poor mechanical properties. Although Lewis acid doped polyanilines have film-forming properties, the resulting films are brittle and easily break. It has recently been shown that mechanical properties of Brönsted acid doped PANI and in particular its stretchability can significantly be improved if appropriate plasticizing groups are introduced to the polymer matrix either as an inherent part of the doping anion, as it was demonstrated by Kulszewicz-Bajer et al who used plasticizing anions of diesters of 5-sulfo-phthalic acid as dopants [7], or in a form of an external plasticizer used in association with non-plasticizing dopant anions, as demonstrated by Fedorko et al. who applied triphenylphosphate as an external plasticizer in camphorsulphonic acid doped polyaniline [115].

Inspired by these findings we were tempted to use, in addition to FeCl_3 , a co-dopant which would improve the mechanical properties of Lewis acid doped PANI and, if possible, would result in an improvement of its environmental stability. The co-dopant of choice is hexafluoroacetylacetonone, abbreviated in the subsequent text as HFAA. Why should HFAA improve the stability and mechanical properties of FeCl_3 doped polyaniline? First, it must be stated that perfluorated ketones and alcohols are known to plasticize polyaniline. Second, if introduced to the polymer matrix they are expected to replace two monodentate Cl^- ligands with two HFAA^- bidentate ones in the cationic iron complex created upon FeCl_3 doping of PANI. The resulting hexacoordinated complex should be more stable than the initial tetracoordinated one. Moreover its acac^- ligands should play the role of internal plasticizers. The addition of HFAA indeed improves the stability and mechanical properties of FeCl_3 doped polyaniline. However, as shown by elemental analysis and spectroscopic investigations, the above outlined concept, although intellectually very attractive, has nothing to do with the reality (*vide infra*).

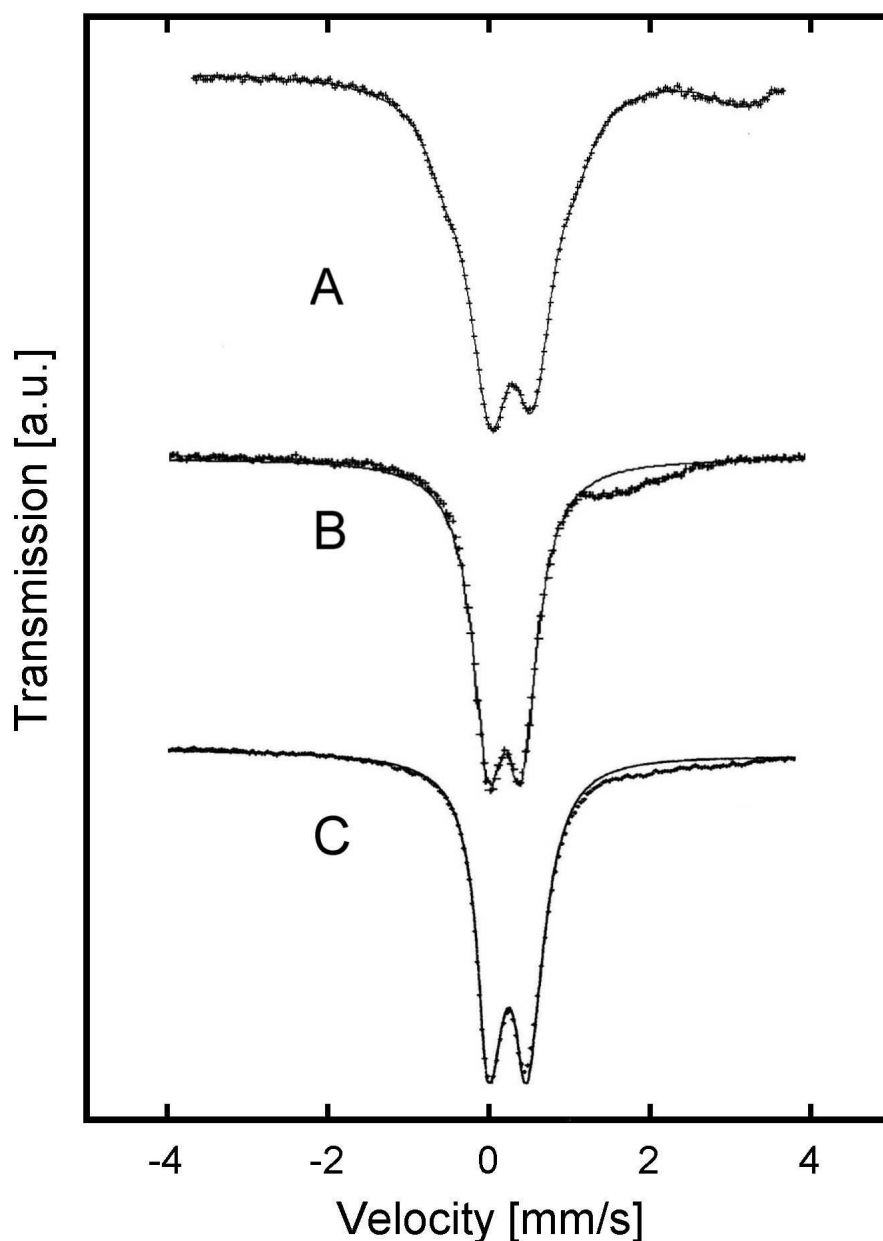

Fig. IV.3.1 Mössbauer spectra of: A) polyaniline base doped with FeCl_3 and dried under high-vacuum B) PANI/ FeCl_3 processed with triple excess of HFAA and pumped under high-vacuum for 8 hours C) PANI/ FeCl_3 processed with triple excess of HFAA and pumped under high-vacuum for 40 hours. Spectra registered at 4K.

In all experiment HFAA was added to the nitromethane solution of FeCl_3 doped PANI in the FeCl_3 to HFAA molar ratio of 1 to 3 in order to exclude the problem of HFAA deficit if $\text{Fe}(\text{HFAA})_3$ would be the dominant product.

The effect of the addition of the co-dopant on the chemical composition and spectroscopic properties of the polymer films cast from nitromethane solution has been followed by Mössbauer effect, EPR and FTIR spectroscopies and by elemental analysis.

In fig.IV.3.1 Mössbauer spectrum of PANI(FeCl₃)_{0.87} is compared with the spectra obtained for the same polymer after the addition of HFAA. As it has already been described the spectrum of FeCl₃ doped PANI consists of two doublets: the “internal” one originates from anionic complexes of iron (FeCl₄⁻ dopants) whereas the “external” one is ascribed to the cationic complexes of iron attached directly to the polymer chain. In addition, broad lines characteristic of Fe²⁺ contamination are present in the spectrum. The addition of HFAA results in a total disappearance of the “external” doublet with no appearance of new Mössbauer lines which unequivocally indicates that the cationic iron complexes, attached to the polymer chain, are efficiently removed from the polymer matrix by the action of HFAA. Hexafluoroacetylacetone also removes the Fe²⁺ contamination as evidenced by an essentially complete disappearance of the signals corresponding to Fe(II) in samples dynamically pumped for an extended period of time (see fig.IV.3.1 and table 4.3.1). The removal of a large fraction of iron is confirmed by elemental analysis, which shows a decreased content of iron in the samples of the polymer treated with HFAA.

Sample	Mössbauer parameters	site 1 (Fe ³⁺)	site 2 (Fe ³⁺)	Fe ²⁺ signal[*]
PANI/FeCl ₃ /CH ₃ NO ₂	I.S. [mm/s]	0,32	0,48	1,15
	Q.S. [mm/s]	0,38	0,89	3,10
	intensity [%]	43	45	12
PANI/ FeCl ₃ /HFAA, pumped for 8 hours	I.S. [mm/s]	0,34	-	not det.
	Q.S. [mm/s]	0,43	-	not det.
	intensity [%]	89	-	11
PANI/ FeCl ₃ /HFAA, pumped for 40 hours	I.S. [mm/s]	0,34	-	not det.
	Q.S. [mm/s]	0,43	-	not det.
	intensity [%]	97	-	3

Table 4.3.1 Mössbauer parameters of PANI doped with FeCl₃ and PANI doped with FeCl₃ subsequently treated with HFAA (Fe:HFAA molar ratio = 1:3) Spectra measured at 4K

The observed evolution of the Mössbauer spectra and the elemental analysis can be explained by the set of reactions schematically depicted in fig.IV.3.2.

* Due to a rather broad pattern, Mössbauer parameters for some Fe²⁺ signals cannot be determined

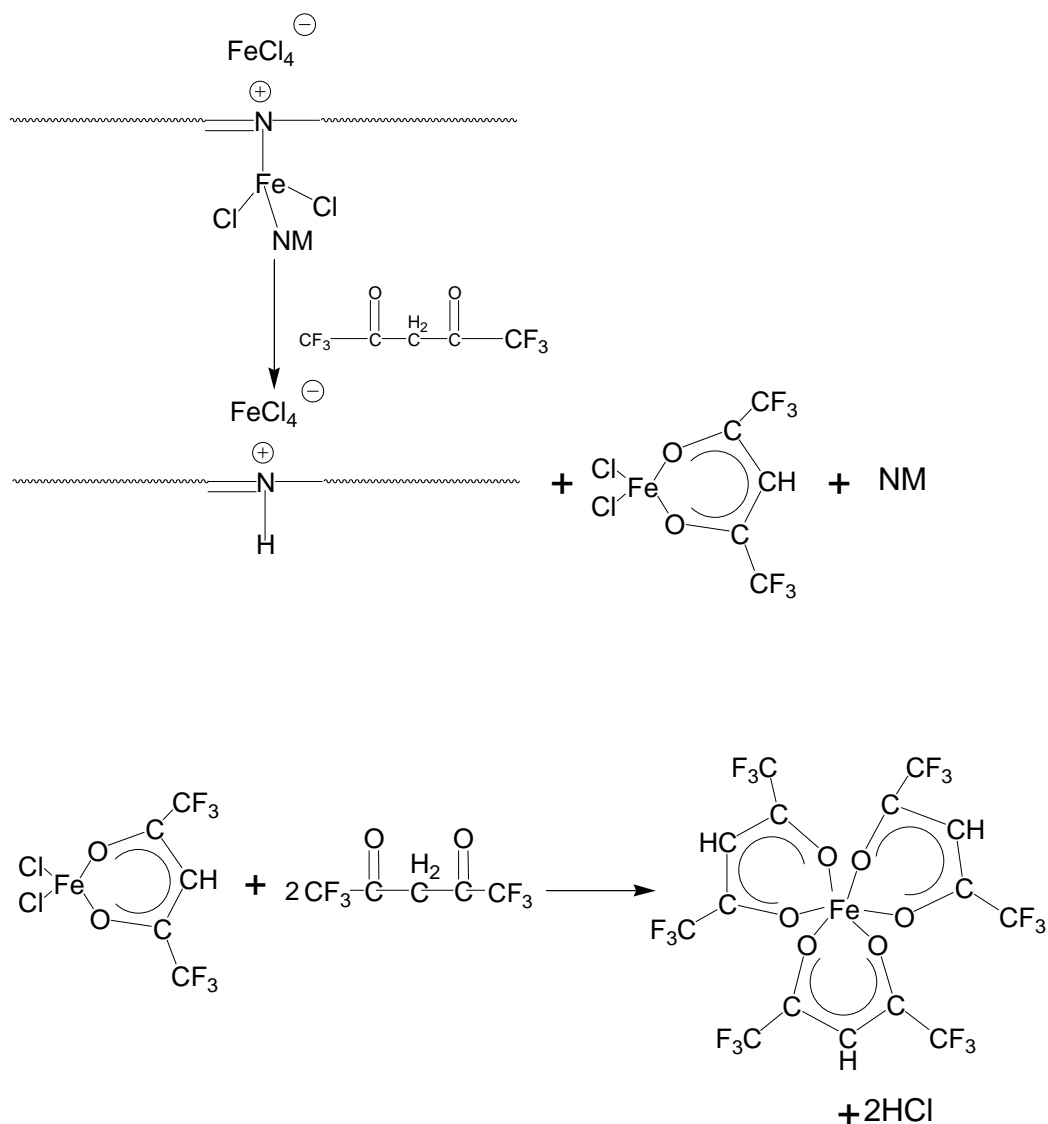

Fig. IV.3.2 Reactions occurring during treatment of PANI/FeCl₃ with triple excess of HFAA

In the first step, in the reaction of HFAA with the cationic complex of iron associated with the polyaniline chain, FeCl₂(HFAA) is formed with simultaneous protonation of the polymer chain. FeCl₂(HFAA) reacts then with the excess of HFAA to give Fe(HFAA)₃ which, being volatile [116], is removed from the system by extended pumping. Similarly, Fe²⁺ contaminations in the reaction with HFAA form volatile Fe(HFAA)₂ which is removed from the polymer matrix by pumping. An additional proof of this sequence of reactions comes from the mass spectrometry investigations of orange colour volatile reaction products condensed in the liquid nitrogen trap. The mass spectrum of the mixture of the condensable reaction products is presented in fig. IV.3.3. In particular, in addition to the peak characteristic of HFAA⁻ anion at m/e = 207,1, a strong peak attributed to Fe(III) hexafluoroacetylacetonate can be found at m/e = 883,4 (Fe(HFAA)₄⁻ anion). This peak is

accompanied by a peak of a smaller intensity at $m/e = 676.8$ arising from the presence of Fe(II) hexafluoroacetylacetonate ($\text{Fe}(\text{HFAA})_3^-$ anion).

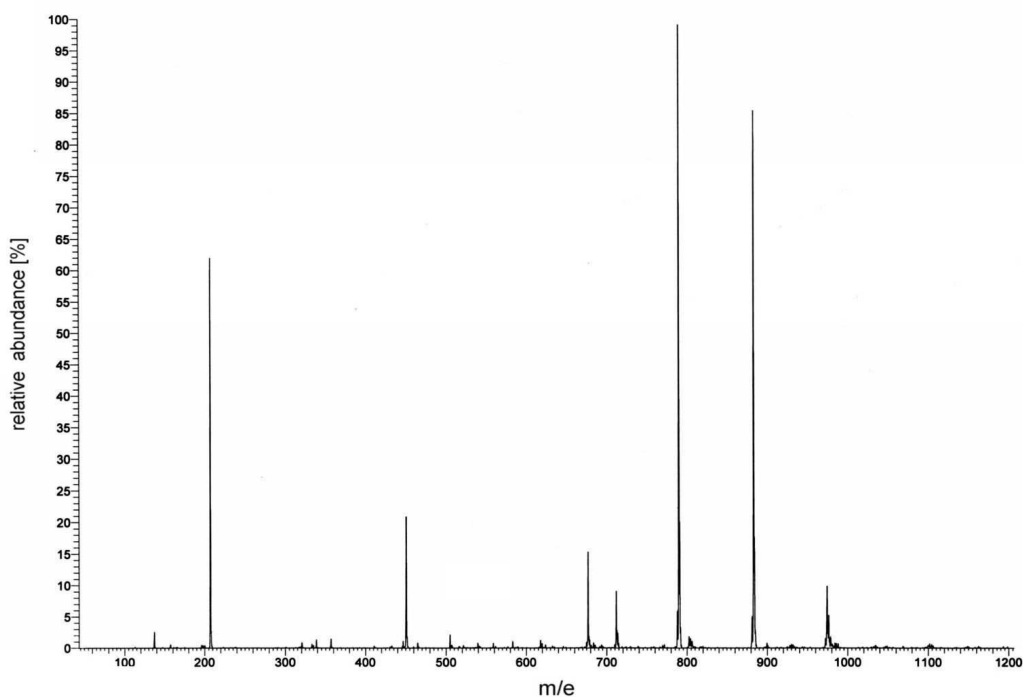

Fig. IV.3.3 Mass spectrum of the species condensed in liquid nitrogen trap during synthesis of PANI/ FeCl_3 /HFAA.

Thus, mass spectrometry studies strongly confirm the reaction mechanism depicted in fig.IV.3.2.

The comparison of the analytical data collected in table 4.3.2 and the Mössbauer effect results (table 4.3.1) indicates that only *ca.*2/3 of the cationic complexes of iron are removed from the polymer matrix as a result of the reaction with HFAA. The Fe to aniline unit molar ratio does not decrease from 0.87 to 0.435, as it would be expected if the reaction depicted in fig. IV.3.2 was quantitative with respect to the cationic complexes of iron. Instead, in the polymer treated with HFAA this ratio is 0.60. This means that the remaining *ca.* 1/3 of cationic iron complexes are transformed into HFeCl_4 which dopes the polymer via protonation. This finding is fully consistent with the results of Mössbauer spectroscopy, which detects only one form of iron (FeCl_4^-).

Based on the above-described scientific findings, it can be postulated that HFAA reacts only with the cationic complexes of iron, leaving the anionic ones intact. Via this reaction, followed by the removal of $\text{Fe}(\text{HFAA})_3$, FeCl_3 doped polyaniline is transformed into a doped system resembling FeCl_3 doped polyaniline hydrochloride with FeCl_4^- as the sole form of iron.

Sample	%C	%H	%N	%Cl	%Fe	%F
PANI doped with FeCl ₃ – found	31,89	2,48	8,51	31,36	17,19	-
calculated for (C ₆ H _{4,5} N) ₁ [(FeCl ₂ ⁺)(FeCl ₄ ⁻)] _{0,41} (CH ₃ NO ₂) _{0,54} (H ₂ O) _{0,20}	30,16	2,51	8,32	32,62	17,17	-
PANI doped with FeCl ₃ , treated with HFAA - found	32,84	2,46	6,40	36,26	15,98	4,42
calculated for (C ₆ H _{4,5} N) ₁ (HFeCl ₄) _{0,60} (C ₅ H ₂ F ₆ O ₂) _{0,09}	33,89	2,31	6,12	37,22	14,70	4,48
PANI/(HCl) _{0,36} doped with FeCl ₃ , treated with HFAA - found	36,04	2,57	6,96	30,26	12,74	5,20
calculated for (C ₆ H _{4,5} N) ₁ (HFeCl ₄) _{0,45} (C ₅ H ₂ F ₆ O ₂) _{0,09}	38,65	2,49	6,99	32,44	12,86	5,12

Table 4.3.2 Elemental analyses of polyaniline doped with FeCl₃, polyaniline doped with FeCl₃ and subsequently treated with HFAA (Fe:HFAA molar ratio = 1:3) and polyaniline hydrochloride doped with FeCl₃ and treated with HFAA (Fe:HFAA molar ratio = 1:3)

The excess of HFAA is retained in the polymer matrix (approximately 1 molecule per 11 aniline units) and serves as an external plasticizer improving the mechanical properties of the doped polymer which becomes much more flexible than original PANI(FeCl₃)_{0,87}. At the end, it should be noted that no presence of nitromethane is required to fit the elemental analysis of the HFAA treated polymer. The absence of nitromethane is not unexpected. In FeCl₃ it plays the role of a ligand completing the coordination sphere of the cationic complex of iron. Upon the reaction with HFAA the cationic complex is removed and the pseudoprotonated (FeCl₂⁺) polymer chain is transformed into the protonated one, which does not require the solvation with nitromethane.

If this interpretation is correct, the Mössbauer spectrum of the solid film of PANI, first pseudoprotonated with [FeCl₂⁺FeCl₄⁻] and then treated with HFAA, should resemble that of PANI first protonated with HCl, then treated with FeCl₃ and finally treated with HFAA. The spectrum of the latter system is presented in fig. IV.3.4. The parameters of the only Fe(III) doublet in the spectrum are exactly the same (IS=0,34; Q.S.=0,38) as those presented in table 4.3.1. The quantity of Fe²⁺ impurities is very low (4%), but in this case a weak doublet at (I.S. = 1,33; Q.S =2,43) is detected. Compound containing iron nuclei with exactly the same Mössbauer parameters are not found in the literature, but it may be noted that compounds such as hydrated derivatives of Fe(II) hexafluoroacetylacetonate i.e. Fe(HFAA)₂*2H₂O give a doublet of very similar parameters [117]. This may suggest that treating of PANI/FeCl₃/HFAA results in formation of Fe(HFAA)₂*2H₂O and possibly its derivatives. Ferrous complexes with hexafluoroacetylacetonate are as volatile as ferric ones

and this is the reason why extended pumping results in an almost complete removal of the Fe^{2+} contamination. Finally, the elemental analysis of this sample (see table 4.3.2) is fully consistent with the postulate that FeCl_4^- is the only form of iron in the doped polymer and HFAA serves as an external plasticizer.

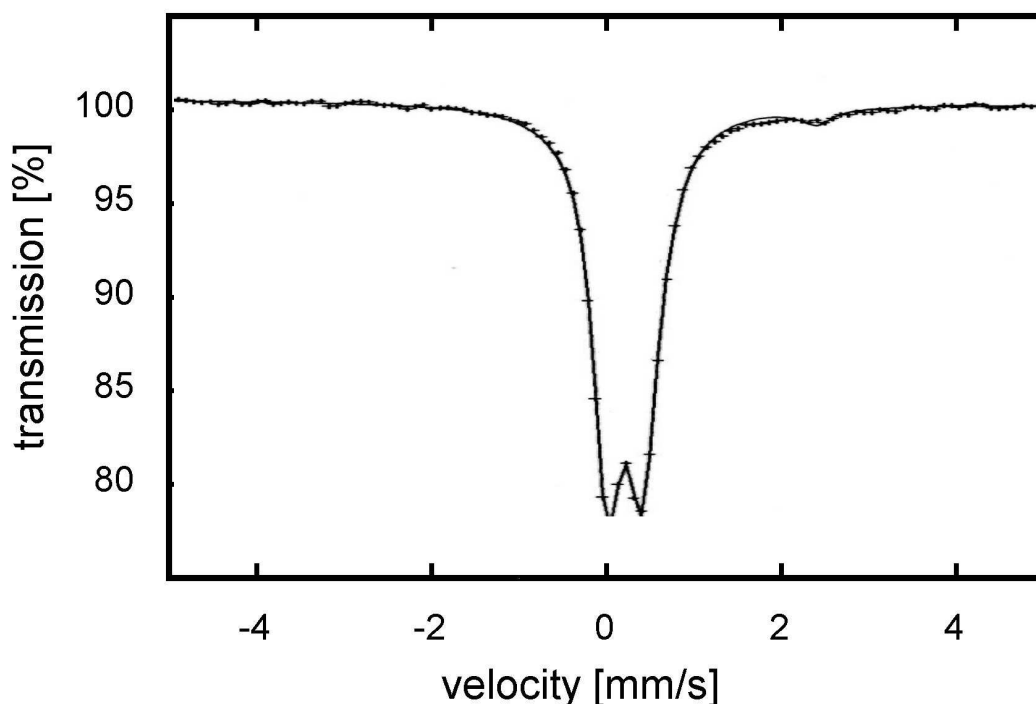

Fig. IV.3.4 Mössbauer spectrum of polyaniline hydrochloride doped with FeCl_3 (1:0,5) and subsequently treated with HFAA. Spectrum registered at 4K.

Global description of the chemical processes occurring in PANI first doped with FeCl_3 , then treated with HFAA and finally pumped for an extended period of time is presented in fig.IV.3.5.

The presence of the radical cation form of the doped polymer, as depicted in fig.IV.3.5, is confirmed by the EPR studies of the polymer doped with FeCl_3 and then treated with HFAA. A typical spectrum is shown in Fig.IV.3.6. A strong signal with g value ~ 2 , characteristic of polyaniline radical cations is significantly broadened ($\Delta H_{pp} \approx 1400$ G) by interactions with of mobile spins of the polymer chains (polarons) with fixed spins of paramagnetic FeCl_4^- dopant ions [118].

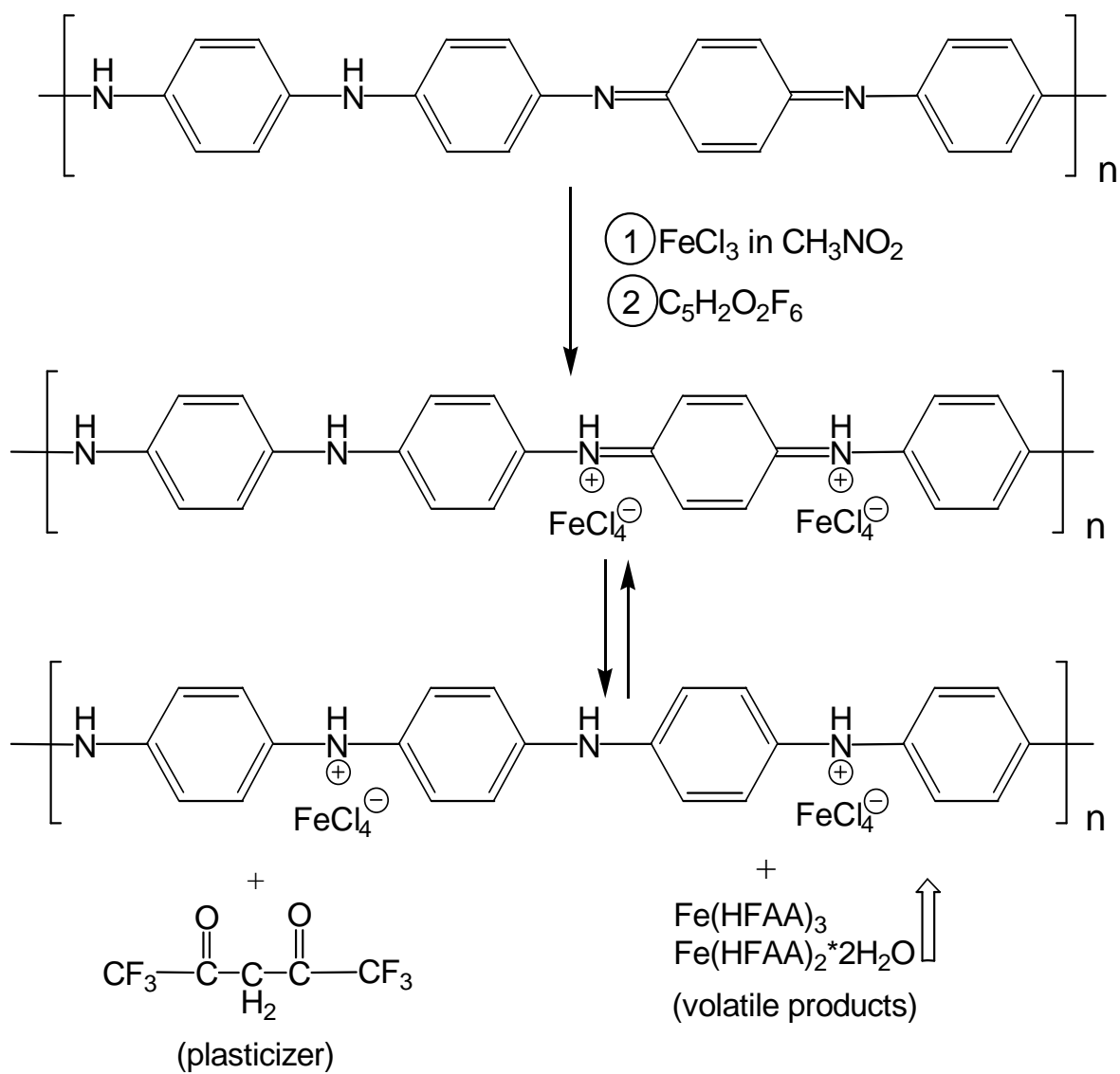

Fig.IV.3.5 Schematic representation of the reaction of emeraldine base with FeCl_3 and hexafluoroacetylacetone (HFAA) in nitromethane.

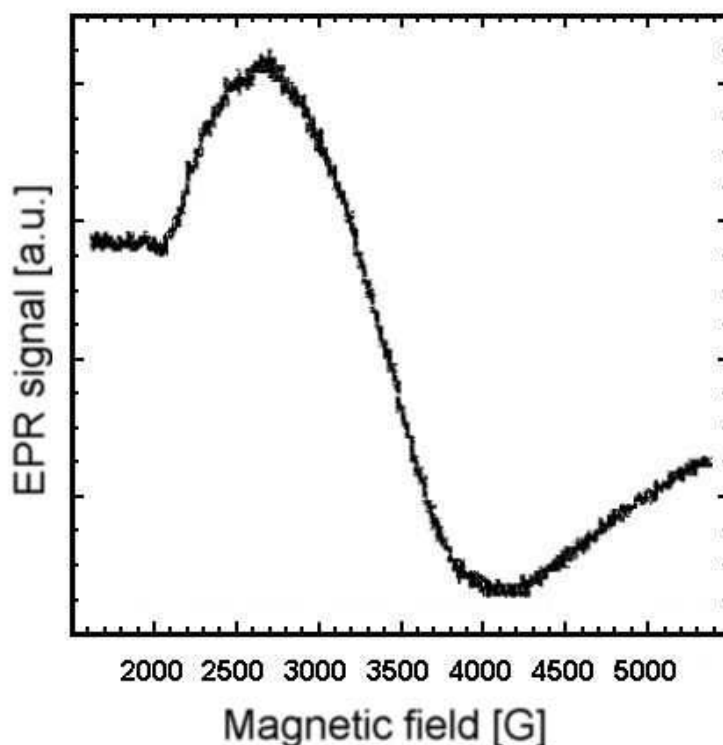

Fig.IV.3.6 EPR spectrum of polyaniline doped with FeCl_3 and additionally treated with HFAA

The FTIR spectrum registered for polyaniline doped with FeCl_3 and subsequently treated with HFAA is shown in fig. IV.3.7, whereas the attributions of the vibrational modes are presented in table 4.3.3.

The spectrum is dominated by the modes characteristic of hexafluoroacetylacetone and its iron complexes [119], despite the fact that these components of the doped systems are in strong minority as compared to the polymer and the dopant anions. This is a clear consequence of high molar absorption coefficients of the vibrations originating from fluorinated β -diketones (their modes are marked [X] in table. 4.3.3.). It should be noted that according to [119] O-H vibrations indicate the presence of water in the $\text{Fe}(\text{HFAA})_2 \cdot 2\text{H}_2\text{O}$ complex. This additionally corroborates that the above compound is a residual product of the “purification” reaction of the doped PANI, which was not removed by extended pumping.

As expected, FeCl_3 doped PANI and subsequently treated with HFAA is more environmentally stable as compared to $\text{PANI}(\text{FeCl}_3)_{0.87}$ since the cationic complexes of iron, being the major source of instability, are efficiently removed from the system.

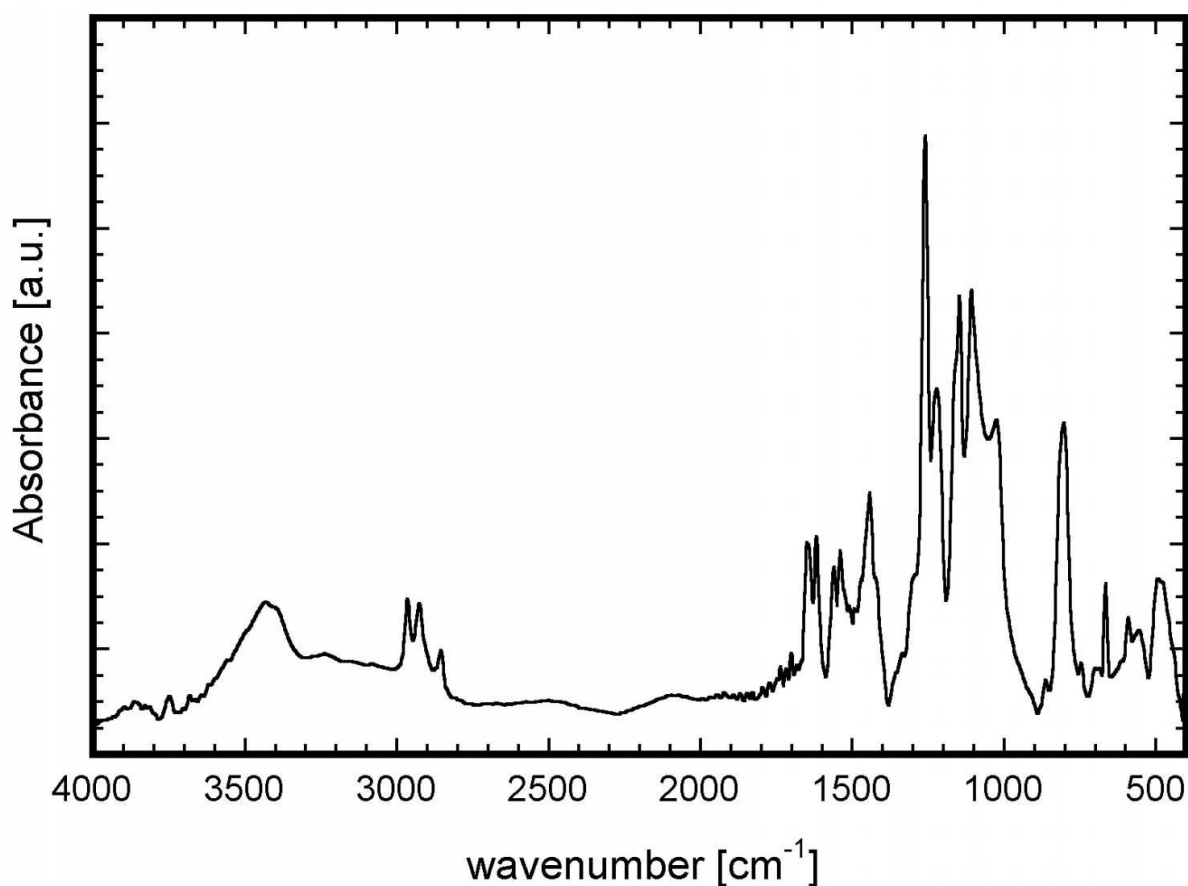

Fig. IV.3.7 Infrared spectrum of polyaniline doped with FeCl₃ (1:1) and subsequently treated with HFAA

Wave number [cm ⁻¹]	Attribution
~3500	O-H stretch(X), N-H stretch
~2950	C-H stretch (X)
1648, 1642	C=O stretch (X)
1618	C=C stretch (X)
1560	C=C stretch in a quinoid ring in protonated PANI, C=O stretch (X) C-H bending (X)
1539, 1442	C=O stretch (X), C-H bending (X)
1260,1222	C-F ₃ stretch (X)
1147,1107	C-H in plane bending (X)
1025	Deformational of aromatic ring + C-H bending in protonated PANI
803	Deformational C-H (out of plane) of 1-4 disubstituted aromatic ring, C-H out of plane bending (X), C-CF ₃ stretch (X),
746	C-CF ₃ stretch (X),
665	C-CF ₃ stretch (X),

Table 4.3.3 IR vibrational modes of polyaniline doped with FeCl₃ (1:1) treated with HFAA

The conductivity of as prepared sample, measured in a dry box i.e. in anhydrous conditions, is $\sigma = 10^{-3}$ S/cm. Upon exposure to ambient atmosphere a twofold increase of the conductivity is observed within the first 20 hours, then it drops to *ca.* 70% of its initial value and finally stabilizes after *ca.* 50 hours. The following explanation for the initial conductivity increase can be proposed. Consecutive doping of PANI base with FeCl₃ and HFAA leading to PANI(HFeCl₄)_x(HFAA)_y has been carried out in anhydrous conditions. It is known that the electronic conductivity of PANI protonated with HCl can be strongly enhanced by the presence of water molecules coordinated to the doped polymer chain via so called “proton exchange assisted conductivity enhancement” [120]. In this respect, adsorption of water molecules, originating from the atmosphere, on previously anhydrous doping sites of the polymer chain, should inevitably lead to an increase of the conductivity. The reason for the conductivity drop observed after its initial increase is not easy to explain at the present time. It must be however associated with morphological changes occurring during the final stages of water adsorption.

IV.3.2 Mixed doping of polyaniline derivatives with iron (III) chloride in the presence of hexafluoroacetylacetone – a comparative study

Hexafluoroacetylacetone plasticizes polyaniline doped with FeCl₃, simultaneously allowing for an efficient removal of ferrous impurities from this polymer. In this section analogous systems based on polyaniline derivatives, namely poly(2-ethylaniline) and polyanisidine are compared with PANI-HFeCl₄-HFAA. The samples were prepared analogously to the case of the PANI-HFeCl₄-HFAA system i.e. the base forms of both polymers were first doped with FeCl₃ and then treated with HFAA. In each case doped polymer was pumped for 40 hours in a dynamic vacuum, after this period orange products did not condense any more in the nitrogen trap, indicating that all volatile products were removed from the system.

Mössbauer spectra of PANIZ, P2EA doped with FeCl₃ and subsequently treated with HFAA systems are shown in fig. IV.3.8. The calculated Mössbauer parameters are collected in table 4.3.4.

In both cases the spectra are composed of one intensive doublet originating from high spin Fe(III) and a group of weaker signals characteristic of high spin Fe(II). The parameters of the Fe³⁺ doublet are very similar for both polymers and are very close to the parameters calculated for the PANI/FeCl₃/HFAA system (see table 4.3.1). Thus, it can be postulated that in all cases studied the dominant lines originate from the presence of FeCl₄⁻ dopant anions in the polymer matrices.

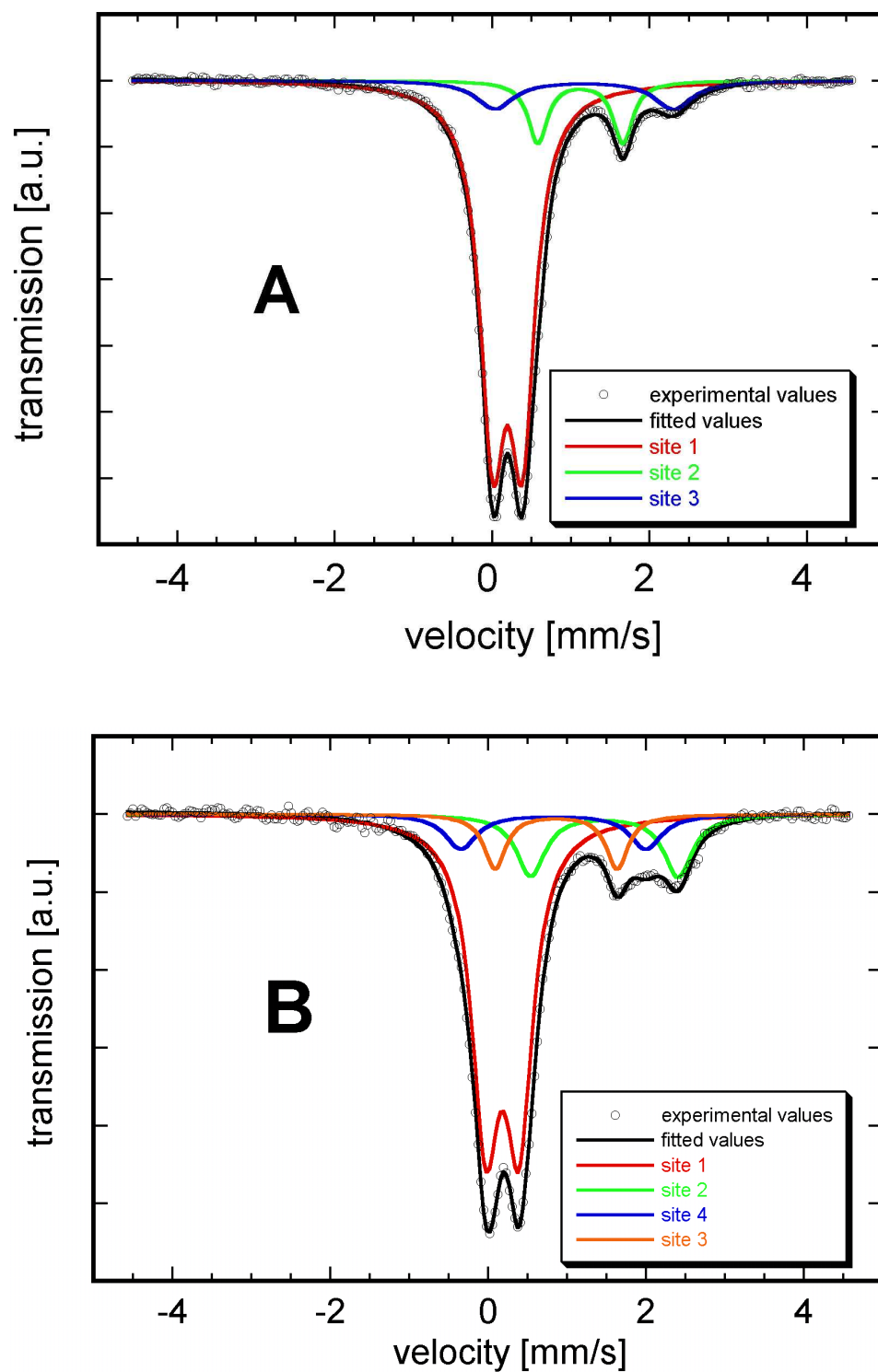

Fig. IV.3.8 Mössbauer spectra of A) polyanisidine, B) poly(2-ethylaniline), all compounds were treated with $FeCl_3$ and subsequently processed with triple excess of HFAA. Samples pumped for 40 hours, spectra registered at 77K.

Sample	Mössbauer parameters	site 1 (Fe ³⁺)	site 2 (Fe ²⁺)	site 3 (Fe ²⁺)	site 4 (Fe ²⁺)
PANIZ/FeCl ₃ /HFAA	I.S. [mm/s]	0,31	1,24	1,28	-
	Q.S. [mm/s]	0,40	1.08	2.27	-
	intensity [%]	79	11	10	-
P2EA/FeCl ₃ /HFAA	I.S. [mm/s]	0,33	1,12	1,13	1,37
	Q.S. [mm/s]	0,45	2,47	1,34	2,52
	intensity [%]	67	13	13	7

Table 4.3.4 Mössbauer parameters of the PANIZ and P2EA doped with FeCl₃ and treated with triple excess of HFAA. Samples pumped for 40 hours, spectra registered at 77K.

In any of the system studied (including polyaniline discussed in chapter IV.3.1) no line attributable to either uncomplexed FeCl₃ or Fe(HFAA)₃ can be detected. Site 2 in doped poly(2-ethylaniline) can be attributed to FeCl₂*2H₂O, but the parameters of the remaining of Fe²⁺ sites can be ascribed neither to iron (II) - β -diketonato complexes nor iron (II) halide hydrates [121]. Thus, it is postulated that some mixed ligand complexes may be present in the sample. Similarly, the Fe(II) registered for doped PANIZ are not easy to ascribe.

As it has already been mentioned only the spectra registered at 4.4 K can be considered as quantitative. The Mössbauer spectra measured at 77 K significantly overestimate the content of Fe(II) contamination because of an unusually low Mössbauer lattice temperature of FeCl₄⁻ dopants as compared to the case of Fe(II) contaminations. Thus, the conclusions concerning the content of Fe(II) in all three polymer studied drawn from the comparison of the Mössbauer parameters collected in tables 4.3.1 and 4.3.4 are not justified.

Elemental analysis carried out for PANIZ/FeCl₃/HFAA system is consistent with the results of the Mössbauer spectroscopy (see table 4.3.5) and underlines its similarity with PANI/FeCl₃/HFAA. In both cases the polymers can be considered as FeCl₄⁻ doped and additionally plasticized with HFAA.

Sample	%C	%H	%N	%Cl	%Fe	%F
PANIZ doped with FeCl ₃ , treated with HFAA - found	31,19	2,63	5,75	31,62	13,36	4,46
calculated for (C ₇ H _{6,5} NO) ₁ (HFeCl ₄) _{0,6} (C ₅ H ₂ F ₆ O ₂) _{0,1}	34,54	2,80	5,37	32,67	12,88	4,37

Table 4.3.5 Elemental analyses of PANIZ doped with FeCl₃ and treated with HFAA

To summarize, we have demonstrated that the treatment of Lewis acid (FeCl₃) doped polyaniline and its derivatives transforms them into Brönsted acid (HFeCl₄) doped polymers plasticized with HFAA. The resulting plasticized polymers show better flexibility as compared to their FeCl₃ doped analogues. Environmental stability studies carried out in the case of polyaniline indicate that, as expected, the new system is more stable with respect to the Lewis acid doped polymer, as far as its conductivity is concerned.

IV.4 DOPING OF POLYANILINE AND ITS DERIVATIVES WITH CHLOROBIS(ACETYLACETONATO)IRON(III)

In chapter IV.3 we have described our attempts to produce *in situ*, during the doping process, polyaniline dopants of Lewis acid type, containing plasticizing groups *via* a direct reaction of FeCl₃ complexed polyaniline with hexafluoroacetylacetone (HFAA). Although the plasticizing effect is clearly observed in this case, detailed studies of the reaction products unequivocally indicate that HFAA acts as an external plasticizer i.e. a plasticizer, which is not directly bonded either to the polymer chain or to the dopant molecule.

The above described finding prompted us to study the doping of polyaniline and its derivatives with mixed chloro-acetylacetonato complexes of Fe(III). By combining polymer chain complexing properties with simultaneous incorporation of plasticizing groups as ligands, these compounds can be considered as bifunctional doping-plasticizing agents, as for example diesters of sulfophthalic acid dopants in the case of Brönsted acid doped polyaniline [7]. Another important aspect of the application of these mixed complexes is their relatively high environmental stability, especially when comparing to ferric halides. Research described in this chapter is focused on the doping of polymers from the polyaniline family with one of the members of this class of complexes, namely chlorobis(acetylacetonato)iron(III).

Initial tests performed in an inert atmosphere (N_2) have shown that no complexation of PANI with $FeCl(acac)_2$ takes place in nitromethane solution. Polyaniline powder dispersed in this solvent does not dissolve upon addition of the complexing agent. To the contrary, PANIZ and P2EA readily form complexes with $FeCl(acac)_2$ in nitromethane which is manifested by deep blue coloration of their solutions.

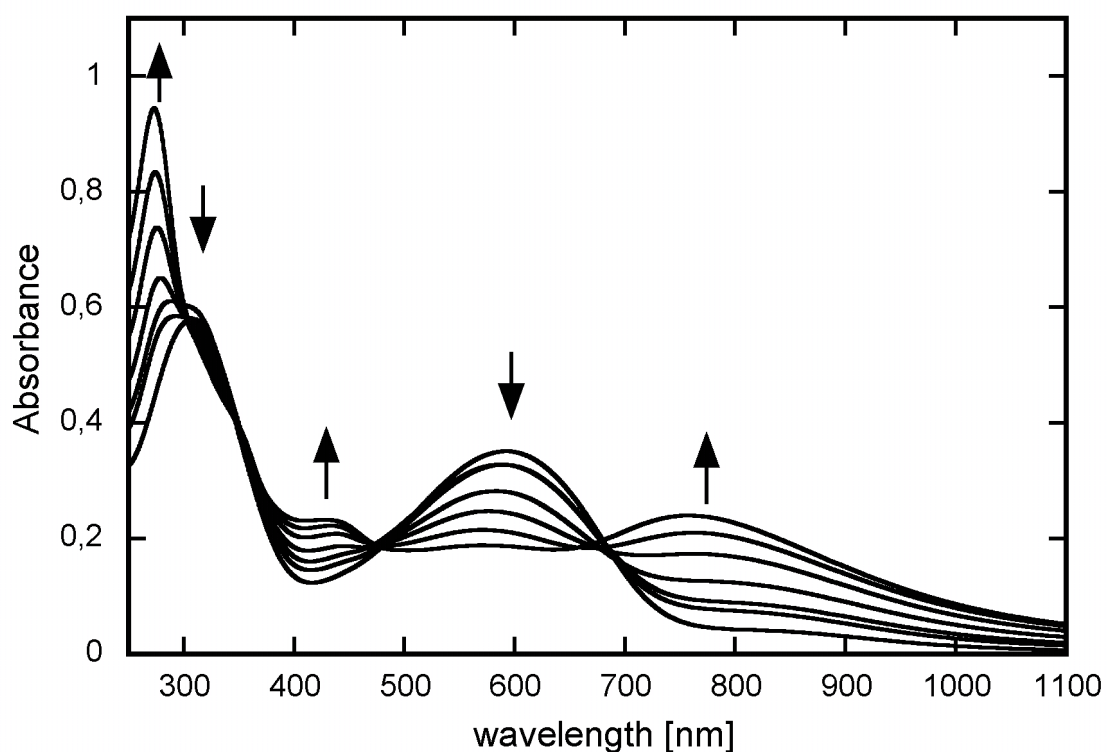

Fig. IV.4.1 UV-Vis-NIR spectra registered during addition of $FeCl(acac)_2$ to polyaniline solutions. Arrows show changes of intensity of the particular peaks when concentration of $FeCl(acac)_2$ increases. Chloroform was used as a solvent.

Chloroform, being a common solvent for P2EA, PANIZ, $FeCl(acac)_2$ and their complexation products, enables the investigation of the doping process in a homogenous medium. The UV-Vis-NIR spectra of the $CHCl_3$ solutions containing increasing quantities of the dopant are presented in fig. IV.4.1 and IV.4.2. In both cases concentration of the polymers are steady. For both P2EA and PANIZ the spectral changes induced by doping with $FeCl(acac)_2$ are of similar type. Upon addition of the complexing agent, two peaks located near 300 nm and 590 nm, which are characteristics of the base (undoped) form of the polymers gradually disappear.

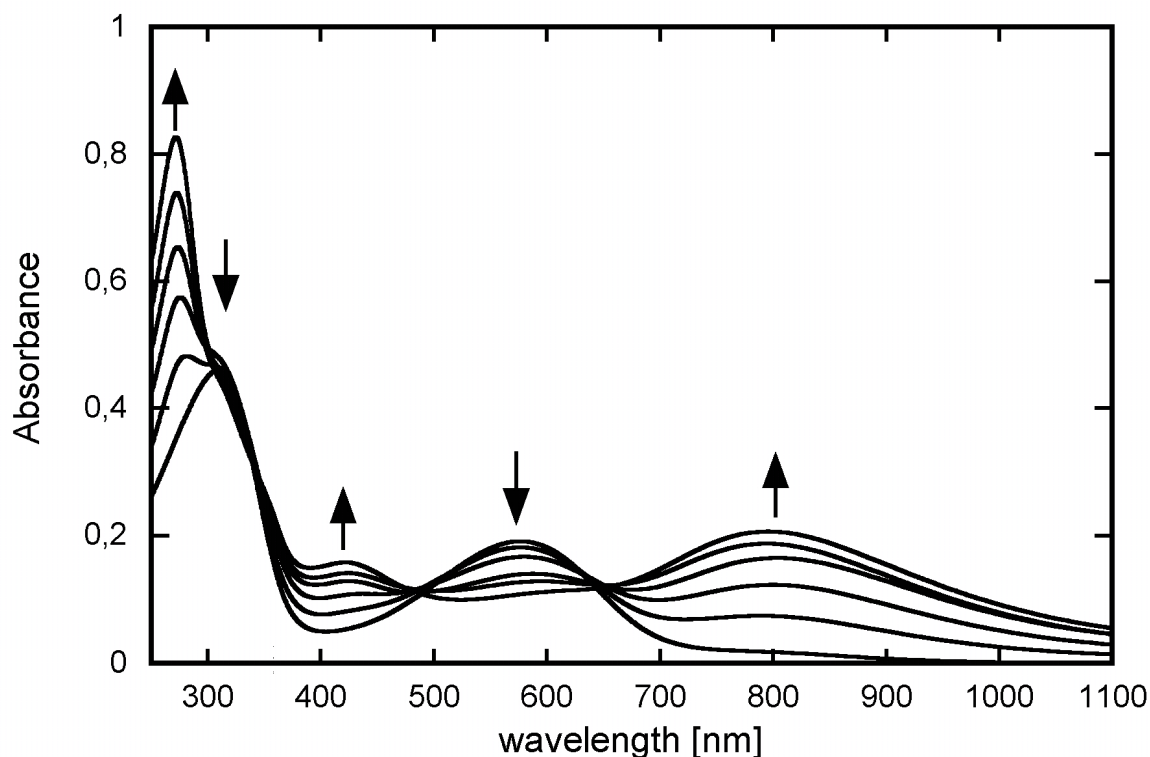

Fig. IV.4.2 UV-Vis-NIR spectra registered during addition of $\text{FeCl}(\text{acac})_2$ to poly(2-ethylaniline) solution. Arrows show changes of intensity of the particular peaks when concentration of $\text{FeCl}(\text{acac})_2$ increases. Chloroform was used as a solvent.

Simultaneously, peaks typical of their doped state appear near 430 nm and 770 nm. The peak at 268 nm - which grows in intensity with increasing quantity of dopant in the solutions - is characteristic of $\text{FeCl}(\text{acac})_2$. At the end, it should be noted that clear isosbestic points observed for the bands associated with the polymers suggest that undoped P2EA and PANIZ are converted into their doped forms with no side reactions.

Spectral features of $\text{FeCl}(\text{acac})_2$ doped polymers are characteristic of radical cations of polymeric nature with localised charge carriers (polarons)[59].

This suggests that the doping process must be similar to the FeCl_3 case and implies coordination of the cationic form of Fe(III) complex on imine nitrogens with the anionic form of the complex serving as a dopant compensating the positive charge of the polymer chain.

As evidenced ^{57}Fe Mössbauer spectroscopy, the picture of the doping process, outlined above is simplified, at least in the case of solid films of the doped polymer. Mössbauer spectra of doped polymers are very complex and cannot be deconvoluted assuming only two nonequivalent iron sites. Representative spectra of $\text{FeCl}(\text{acac})_2$ doped PANIZ and P2EA are shown in figs. IV.4.3 and IV.4.4, respectively. A comparison of the

spectra recorded for freshly prepared samples stored at all times either in vacuum or under an inert atmosphere with those measured for samples exposed to laboratory air for 24 h clearly shows that the doped system is much more environmentally stable as compared to FeCl₃ or AlCl₃ doped polymers, since only minimal, if any, spectral changes are observed upon the exposure to air.

The isomer shift ranges of the obtained subspectra are characteristic of high spin Fe(III) with no signs of the presence of the lines originating from Fe(II). This means that, as expected, the doping reaction is purely acid-base in nature since it does not involve any change in the oxidation state of iron. The deconvolution of these complex spectra is difficult. In principle they can be fitted with three doublets leading however to very broad lines, which suggest that at least some of them must represent a group of signals with a distribution of their isomer shift or quadrupole splitting values. Thus, the results of the deconvolution would not be very helpful in identification of different forms of iron complexes present in the polymer matrix, taking into account a possibly large number of nonequivalent iron sites. We are tempted to attribute these results to a bulky nature of the dopant used. Dopants with spacious groups such as acetylacetonate can of course be complexed on imine nitrogen sites, but due to steric reasons they cannot reach the “ideal” geometry when all cationic complexes interact equally with the free electron pair on nitrogen atoms.

Wave number [cm ⁻¹]	Vibration type
2996, 2967, 2920	C-H stretch
1571	C=C stretch in a quinoid ring
1524	C-C stretch in a benzenoid ring +C-H mixed vib.
1359	C-C stretch (X)
1189	C-H in plane
1117	Deformational of aromatic ring + C-H bending
1021, 1017	C-O stretch, C-O stretch (X)
848, 807	Deformational C-H (out of plane) of aromatic ring
802	C-H (out of plane) bending (X)

Table 4.4.1 IR vibrational modes of polyanisidine doped with FeCl(acac)₂

As a consequence several “internally unsaturated” systems are obtained which exhibit different Mössbauer parameters. In general, spectra of samples, which are not doped to saturation are very complex and show the presence of many nonequivalent iron sites. Such effect was demonstrated by Kulszewicz-Bajer and Suwalski [105] for FeCl₃ doped polyaniline.

Infra-red spectra of PANIZ and P2EA doped with $\text{FeCl}(\text{acac})_2$ are presented in fig. IV.4.5, whereas tables 4.4.1, and 4.4.2 list vibrational modes of the doped polymers.

Wave number [cm^{-1}]	Vibration type
~3350	N-H stretch
~3000	C-H stretch
1571	C=C stretch in a quinoid ring
1524	C-C stretch in a benzenoid ring + C-H mixed vib.
1373	C-C stretch in a benzenoid ring + C-H bending in a benzenoid ring
broad band centered at 1361	C-H bending, C-C stretch (X)
1208	C-N stretch + C-H bending
1117	C-H bending
1020	C-O stretch (X)
1048	Deformational of aromatic ring
891, 816	Deformational (out of plane) of aromatic ring
802	C-H bending out of plane (X)

Table 4.4.2 IR vibrational modes of poly(2-ethylaniline) doped with $\text{FeCl}(\text{acac})_2$

In the spectra modes from both the polymer and the dopant are noticeable. Peaks from the dopant ascribed to the vibration of its particular bonds are marked (X) in both tables. Two intensive peaks at 1571 cm^{-1} and 1524 cm^{-1} are accompanied by lower energy shoulders in both cases. This indicates the presence of C=C stretching and C-H bending vibrations characteristic of $\text{FeCl}(\text{acac})_2$ (modes 1550 cm^{-1} and 1530 cm^{-1} in the spectrum of the pure dopant).

For PANIZ as well as for P2EA, modes characteristic of C=C stretching vibrations of the quinoid ring are redshifted, whereas those ascribed to C-C stretching vibrations of the benzoid ring are blueshifted. This suggests that the dopants interact with imine nitrogens in both polymers.

Elemental analyses carried out for films of doped PANIZ and P2EA cast from nitromethane solutions are presented in table 4.4.3.

Calculations performed for both polymers indicate that quantity of the N:Fe:Cl molar ratio is, within the experimental error, equal to 1:1:1. This means that the dopant does not undergo decomposition during the doping process and all its molecules, present in the doping solution are incorporated to the polymer matrix upon casting.

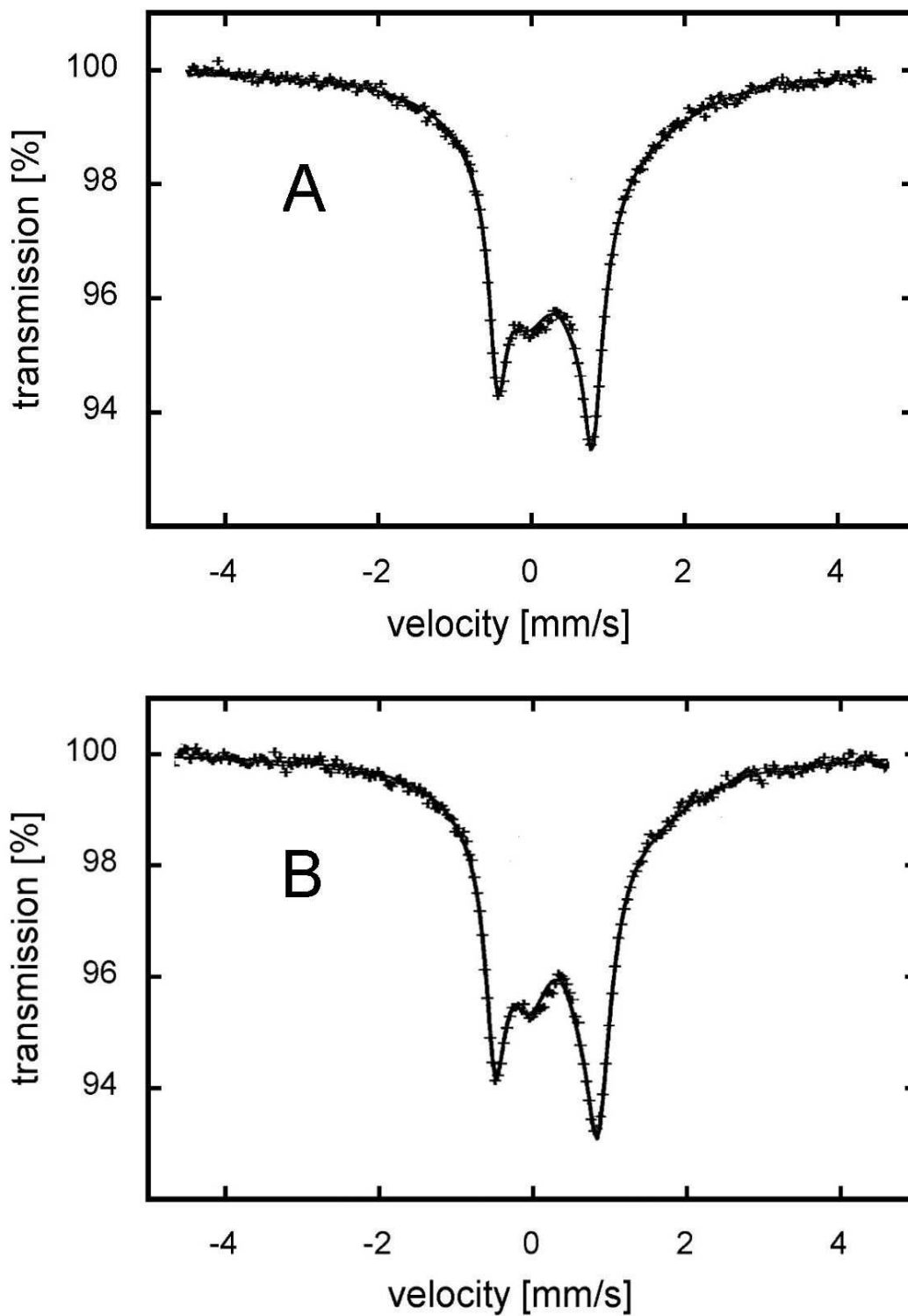

Fig. IV.4.3 Mössbauer spectra of polyanisidine doped with $\text{FeCl}(\text{acac})_2$ in nitromethane. A) spectrum of the freshly prepared sample; B) spectrum of the sample conditioned for 24 hours on air. Spectra were registered at 77K.

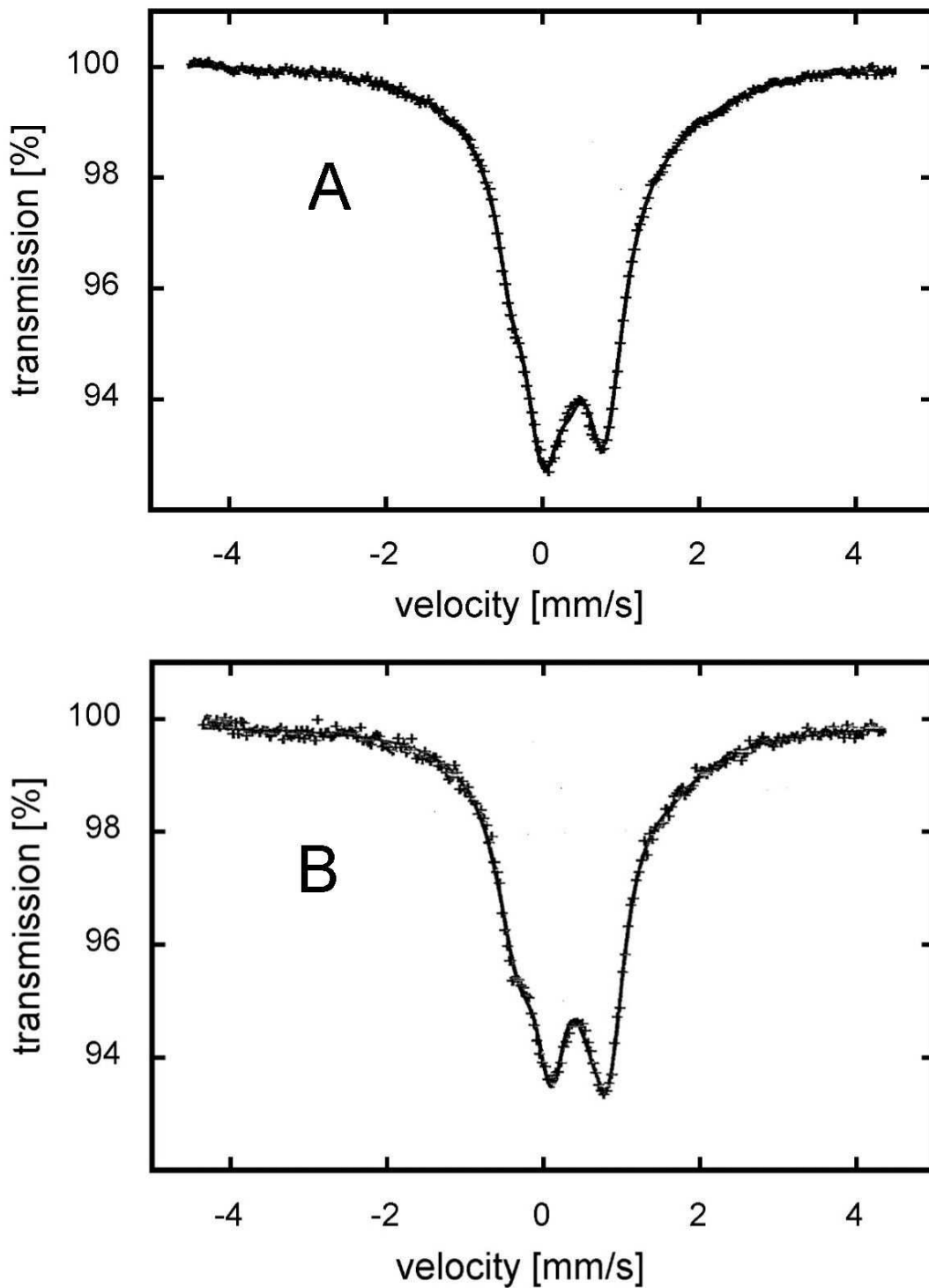

Fig. IV.4.4 Mössbauer spectra of poly(2-ethylaniline) doped with $\text{FeCl}(\text{acac})_2$ in nitromethane. A) spectrum of the freshly prepared powder; B) spectrum of the sample conditioned for 24 hours on air. Spectra were registered at 77K.

	%C	%H	%N	%Cl	%Fe
PANIZ doped with FeCl(acac) ₂ - found	47,50	5,13	3,10	8,22	12,27
calculated for (C ₇ H _{6,5} NO)(FeClC ₁₀ H ₁₄ O ₄) _{0,99} (H ₂ O) _{1,39}	46,77	5,33	3,23	8,09	12,77
P2EA doped with FeCl(acac) ₂ - found	51,52	5,54	3,48	9,04	13,04
calculated for (C ₈ H _{8,5} N)(FeClC ₁₀ H ₁₄ O ₄) _{0,94} (H ₂ O) _{0,615}	52,03	5,69	3,48	8,30	13,10

Table 4.4.3 Elemental analyses of polyanisidine and poly(2-ethylaniline) doped with chlorobis(acetylacetonato)iron(III) in nitromethane.

Contrary to the polymers doped with FeCl₃, the elemental analysis results show that no solvation with nitromethane is required to stabilize the cationic complex coordinated to the imine nitrogen sites. This can be rationalized by the bidentate nature of the acac ligand which together with one chloride ligand and one nitrogen ligand assures tetrahedral coordination around Fe(III) atoms.

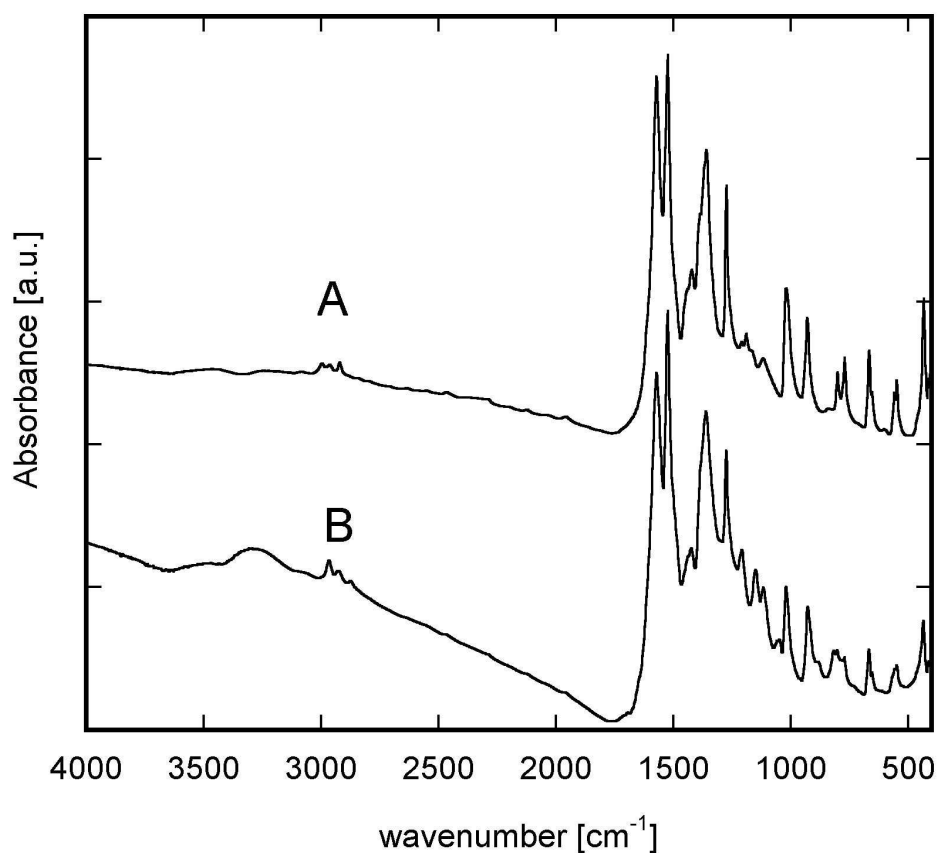

Fig. IV.4.5 Infrared spectra of polyanisidine (A) and poly(2-ethylaniline)(B) doped with FeCl(acac)₂

To summarize, complementary spectroscopic and elemental analysis data show that both PANIZ and P2EA can be doped with mixed chloride-acetylacetonate iron complexes. The doping leads to the formation of radical cations in the polymer chain as a result of the coordination of the cationic Fe(III) complex on the imine nitrogen sites. The exact chemical nature of the anionic and the cationic components of the doped polymer was not possible to determine due to the complexity of the obtained Mössbauer spectra.

IV.5 DOPING OF POLYANILINE AND ITS DERIVATIVES WITH ALUMINIUM (III) CHLORIDE

Taking into account its Lewis acidity, AlCl_3 is a very good candidate for doping polyaniline and its derivatives. Polymers containing complexing centres of Lewis base type, such as poly(*p*-phenylenebenzobisthiazole)s, and poly(*p*-phenylenebenzobisoxazole)s are known to coordinate AlCl_3 [122,123,124]. The acid-base interactions with nitrogen, oxygen or sulphur centres are of practical importance because they lead to an improvement in the solution processibility of these rigid polymers.

It is known, that AlCl_3 dissolved in nitromethane undergoes self-dissociation and simultaneously forms complexes of different type with the molecules of the solvent [125]. Since $\text{AlCl}_3/\text{CH}_3\text{NO}_2$ is the doping medium, spectroscopic identification of the co-existing chemical species is necessary for the elucidation of the doping process. This can be done by ^{27}Al NMR spectroscopy [126].

The ^{27}Al NMR spectrum of an AlCl_3 solution in nitromethane is shown in fig.IV.5.1

Several peaks originating from AlCl_3 self-dissociation or from AlCl_3 – nitromethane complexes can be distinguished. In particular, the peak at 104,9 ppm can, without any ambiguity, be ascribed to the presence of AlCl_4^- anions [124,125]. The line at 99,4 ppm is characteristic of non complexed AlCl_3 . The peak originating from the $\text{AlCl}_3\text{-NM}$ (98,8) adduct is observed as a shoulder of the former signal [127]. Low intensity peaks in the region (90-97 ppm) can be attributed to other complexes between AlCl_3 and the solvent. Peaks in the area (-8)-(-20) ppm are typical of hexacoordinated aluminium species [126]. The presence of the self-dissociation products in the PANI doping solution (eq. IV.3) leads to the conclusion that the mechanism of the AlCl_3 doping of this polymer may be similar to that postulated for the FeCl_3 one (see chapter IV.2).

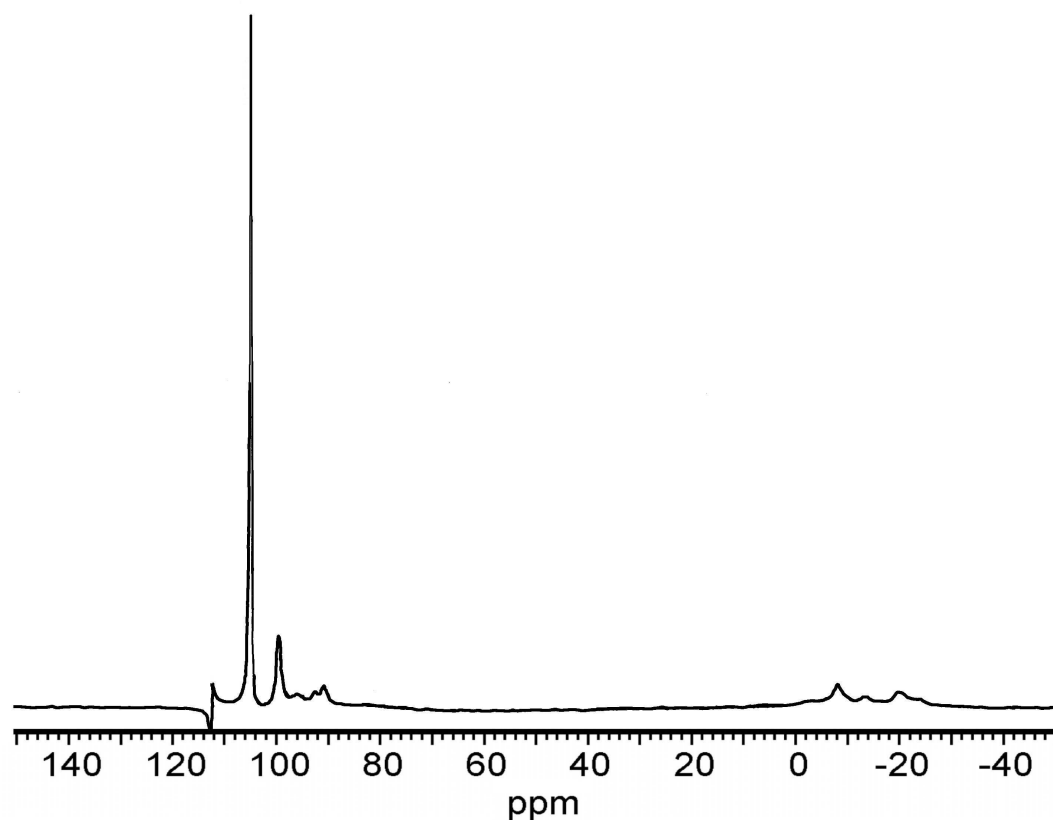

Fig. IV.5.1 ^{27}Al NMR spectrum of 5% AlCl_3 solution in $\text{CD}_3\text{NO}_2/\text{CH}_3\text{NO}_2$ (1:4), registered at room temperature



where PANI denotes the tetramer repeat unit

The above hypothesis is corroborated by NMR studies of the PANI – AlCl_3 – nitromethane mixtures. The addition of PANI to the AlCl_3 /nitromethane solution results in a significant modification of its ^{27}Al NMR spectrum. Independently of the PANI mer to dopant ratio (1:1,25; 1:1,50; 1:1,75 and 1:2) the resulting spectrum is essentially the same with one dominating line at 104,9 ppm which obviously must be ascribed to AlCl_4^- . The absence of the lines attributable to its cationic counterpart requires some explanation.

The phenomenon of “invisibility” of certain aluminium signals in NMR spectroscopy is known from the literature and occurs frequently in complexes with ligands containing nitrogen [124,128]. The exact nature of this effect is not totally understood at this time. It must be however associated with the quadrupole moment of aluminium nuclei, especially important for complexes containing the coordination sphere of low symmetry. This effect combined with short relaxation times leads to a significant broadening of the NMR lines which in certain cases become difficult or even impossible to be detected.

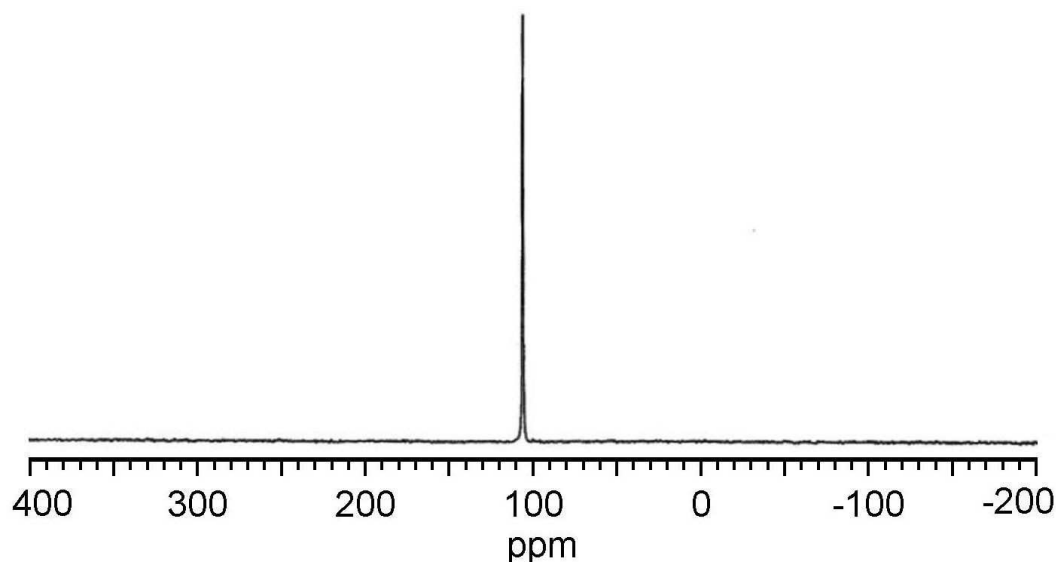
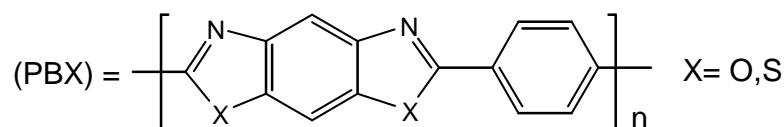
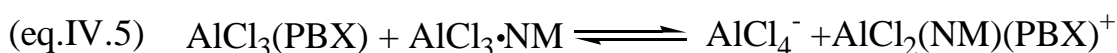

Fig. IV.5.2 ^{27}Al NMR spectrum of polyaniline- AlCl_3 mixture in $\text{CD}_3\text{NO}_2/\text{CH}_3\text{NO}_2$ (1:4) solution at room temperature; mer to dopant ratio (1:1,5)

It is convenient to regard the interactions in the PANI- AlCl_3 -NM ternary system as a competition between two bases (a weaker one (NM) and a stronger one (PANI) to form complexes with the Lewis acid. In this respect the stronger base replaces the weaker one in the complex as it has been demonstrated by the titration of the AlCl_3 -nitromethane complexes with DMF [129]. The same applies to polymers containing basic sites, such as for example PBX [124]:



The addition of PBX to a solution of AlCl_3 in nitromethane first results in the substitution of the nitromethane ligands with the imine ones (eq.IV.4). Then in the reaction of this complex with $\text{AlCl}_3\cdot\text{NM}$ an ionic adduct is formed (eq.IV.5), in the same way as it is postulated for the doping of PANI.



(The equations are written per molecule of AlCl_3 , each PBX repeat unit has two complexing groups)

We can postulate that the Lewis acid doping of PANI with AlCl_3 occurs in a similar way as for PBX. The presence of AlCl_4^- is directly corroborated by NMR. Moreover, in the IR spectra of the doped polymer a band at 410 cm^{-1} can be found ascribed to

Al-O stretchings [125]. This indicates that the molecules of nitromethane constitute an integral part of the complexes formed upon the doping reaction.

A comparison of the ^{27}Al NMR spectra registered for $\text{AlCl}_3/\text{nitromethane}$ with those of $\text{PANI}/\text{AlCl}_3/\text{nitromethane}$ (figs. IV.5.1 and IV.5.2) unequivocally shows that PANI efficiently complexes aluminium chloride since all NMR lines characteristic of “free” AlCl_3 -nitromethane adducts, disappear upon the addition of this polymer. This equilibrium shift is fully consistent with the postulate of the replacement of a weaker base by a stronger one (*vide supra*). This complexation, involving the formation of an ionic adduct in PANI and its derivatives, as described in eq.IV.3, is further confirmed by UV-vis-NIR spectra of AlCl_3 doped polymers, registered for the nitromethane solutions (fig.IV.5.3). Similarly as in the case of the FeCl_3 , NIR spectral features characteristic of the charged species (polarons) appear upon the doping with AlCl_3 . The spectra can be interpreted in the same manner as those of the polymers complexed with FeCl_3 , thus their discussion will not be repeated here. It should only be added that, as judged from the relative intensities of the localized peak in the vicinity of 800 nm and the absorption tail extended towards the NIR part of the spectrum, the polaron delocalization in AlCl_3 doped samples of polyaniline, polyanisidine, poly(2-ethylaniline) is more pronounced than in their FeCl_3 counterparts.

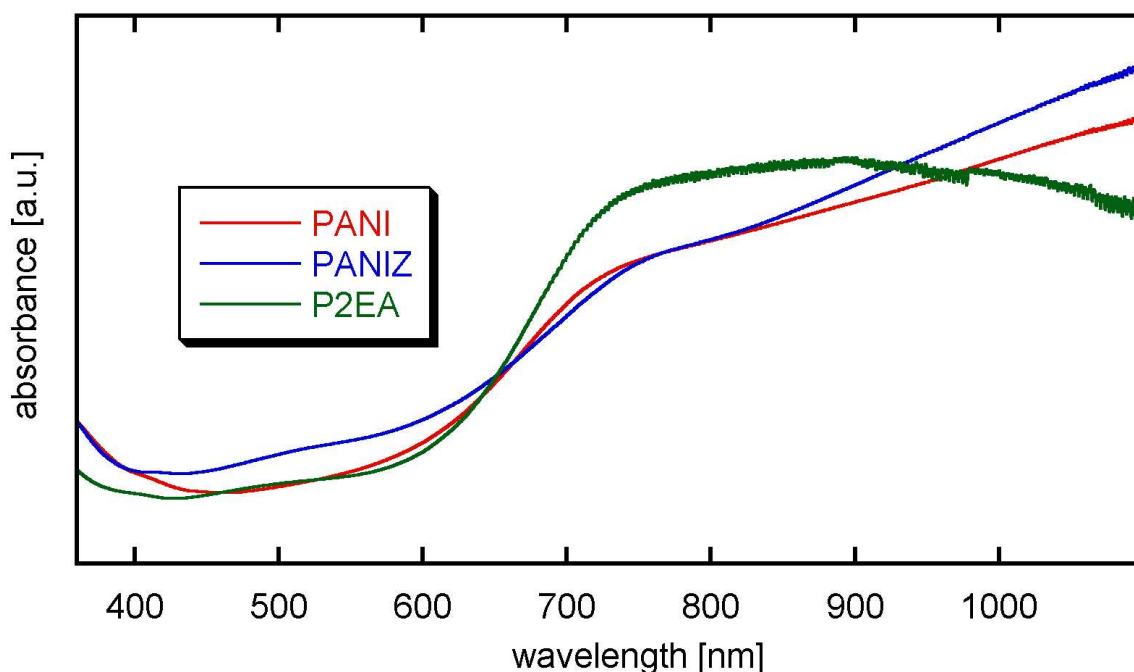

Fig. IV.5.3 UV-Vis-NIR spectra of the nitromethane solutions of polyaniline, polyanisidine and poly(2-ethylaniline) doped with AlCl_3 ; mer to dopant ratio (1:1)

To conclude briefly, all features of the UV-Vis-NIR spectra registered for the PANI- AlCl_3 system exhibit all features characteristic of the polysemiquinone radical cation obtained by charge rearrangement after the complexation with AlCl_2^+ on imine sites of the polymer chain as schematically depicted in (fig. IV.5.4).

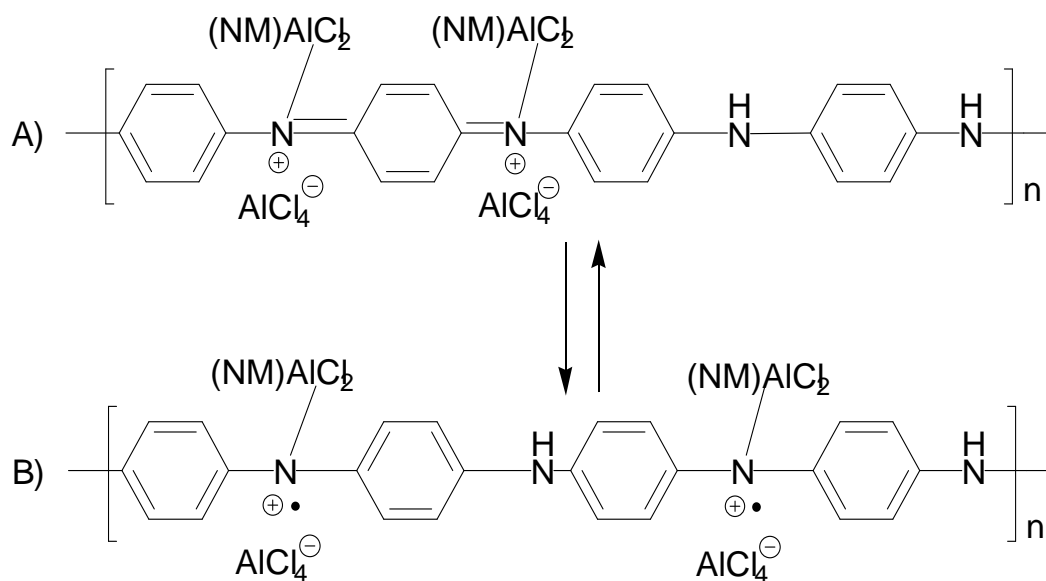

Fig.IV.5.4 Structure of emeraldine treated with aluminium chloride (III) in nitromethane

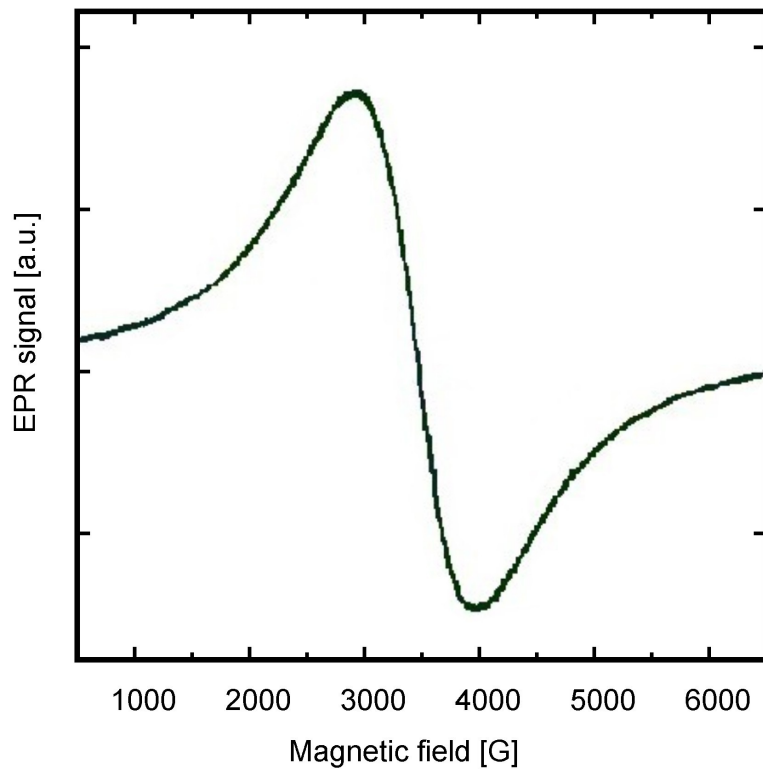

Fig. IV.5.5 EPR spectrum of emeraldine doped with AlCl_3

The formation of this radical cation – type of structure can be directly evidenced by EPR spectroscopy. Emeraldine base shows a weak EPR line of origin, which is not clearly understood at this moment corresponding to 1 spin per 22 units [130]. Doping of this polymer with AlCl_3 results in an increase of the intensity of registered EPR signal, which in addition shows EPR parameters typical of the polymer complexed with diamagnetic ligands ($\Delta H_{pp} \approx 1150 \text{ G}$, $g \sim 2.0$; see fig.IV.5.5).

FTIR spectra of AlCl_3 doped polymers, as far as the spectral region of characteristic of the polymer chain vibrations is considered, are very similar to those of the FeCl_3 doped polymers and contain all spectral features typical of the doped state (compare fig. IV.2.3, fig.IV.5.6 and see the discussion in chapter IV.2) A typical spectrum of polyaniline doped with AlCl_3 is presented in fig. IV.5.6.

In order to verify whether the nitromethane molecule, being an integral part of the complex in the solution, is also present in the solid state complex we have performed elemental analyses of the free standing polymers films obtained by casting. The results are collected in table 4.5.1.

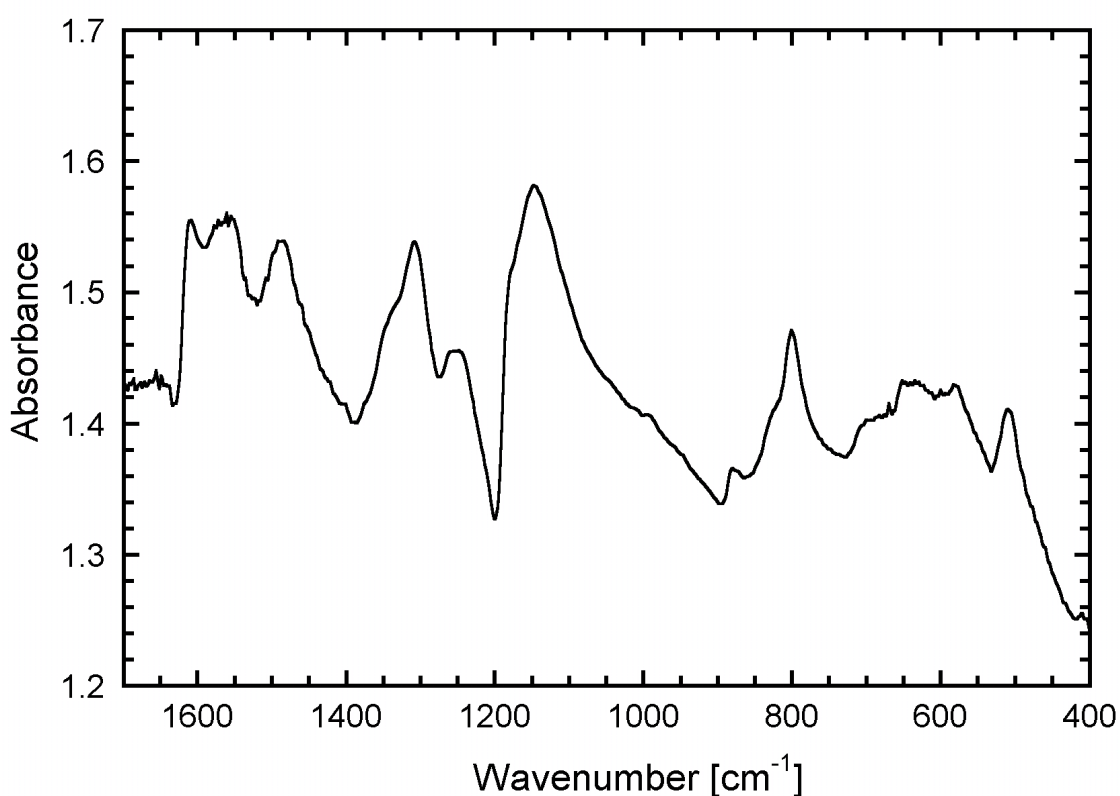

Fig. IV.5.6 IR spectrum ($1700 \text{ cm}^{-1} - 400 \text{ cm}^{-1}$) of polyaniline doped with AlCl_3 ; mer to dopant ratio (1:1)

	%C	%H	%N	%Cl	%Al
PANI doped with AlCl ₃ - found	32,16	2,59	8,29	37,00	10,20
calculated for: (C ₆ H _{4,5} N ₁) ₁ (AlCl ₃) _{0,89} (CH ₃ NO ₂) _{0,42}	32,79	2,45	8,46	40,44	10,22
calculated for: (C ₆ H _{4,5} N ₁) ₁ (AlCl _{2,81} (OH) _{0,19}) _{0,89} (CH ₃ NO ₂) _{0,42}	33,21	2,62	8,57	38,27	10,35
calculated for: (C ₆ H _{4,5} N ₁) ₁ (AlCl _{2,81} (OH) _{0,19}) _{0,89} (CH ₃ NO ₂) _{0,42} (H ₂ O) _{0,29}	32,48	2,80	8,38	37,43	10,13

Table 4.5.1 Elemental analyses of polyaniline doped with aluminium (III) chloride

It is clear that the results of the elemental analysis can be fitted only under the assumption that one nitromethane molecule is incorporated to the polymer matrix per two AlCl₃ molecules i.e. in a very good agreement with the eq.IV.3. Taking into account a lower than expected Cl/Al ratio, some hydrolysis of the dopant species must also be assumed.

To summarize, ²⁷Al NMR data of AlCl₃ doped PANI combined with UV-vis-NIR and FTIR spectroscopies as well as elemental analysis results indicate a very close resemblance of the AlCl₃ doping to the FeCl₃ one. In both cases the positive charges are imposed on the polymer chain via complexation of the cationic product of the doping agent self-dissociation, whereas the anionic product (AlCl₄⁻) assures electrical neutrality of the system.

IV.6 DOPING OF POLYANILINES WITH

DICHLORO (ACETYLACETONATO)ALUMINIUM(III)

Successful doping of polyaniline derivatives with Fe(III) complexes containing mixed chloride – acetylacetonate ligands has prompted us to verify whether the analogous Al(III) complexes can also dope these polymers. We have therefore synthesized AlCl₂(acac) and studied its reactions with polyaniline and its derivatives.

AlCl₂(acac), similarly as FeCl(acac)₂, does not dope polyaniline. The addition of the powder of polyaniline base to a solution of AlCl₂(acac) in nitromethane does not result in the complexation induced dissolution of the polymer. To the contrary, both polyaniline derivatives studied in this research - polyanisidine and poly(2-ethylaniline) – readily

complex $\text{AlCl}_2(\text{acac})$ which is manifested by gradual dissolution of the both polymers in $\text{AlCl}_2(\text{acac})/\text{CH}_3\text{NO}_2$ solutions accompanied by their coloration.

UV-Vis - NIR spectra of $\text{AlCl}_2(\text{acac})$ doped polyanisidine and poly(2-ethylaniline) registered in nitromethane solution are presented in fig. IV.6.1.

First we notice that, similarly as in all previously described cases, the spectra show features characteristic of the transformation of the neutral chains of the base form of the polymers into radical cations. Thus, it can be postulated that the doping with $\text{AlCl}_2(\text{acac})$ must proceed via complexation of the cationic form of the dopant on imine nitrogens, followed by charge rearrangement to produce radical cations.

The spectrum of doped polyanisidine is typical of polyanilines containing strongly localised polarons [74]. In particular, a strong peak near 800 nm is attributed to the π band \rightarrow localised polaron level transition whereas the peak at 440 nm is ascribed to the localised polaron level $\rightarrow \pi^*$ band transition. The spectrum of the doped poly(2-ethylaniline) is similar, however a significant broadening of the less energetic peak, in the direction of the NIR part of the spectrum, indicated a more pronounced polarons delocalisation. No peaks originating from the undoped (base) form of the polymers can be found proving that the doping process is effective.

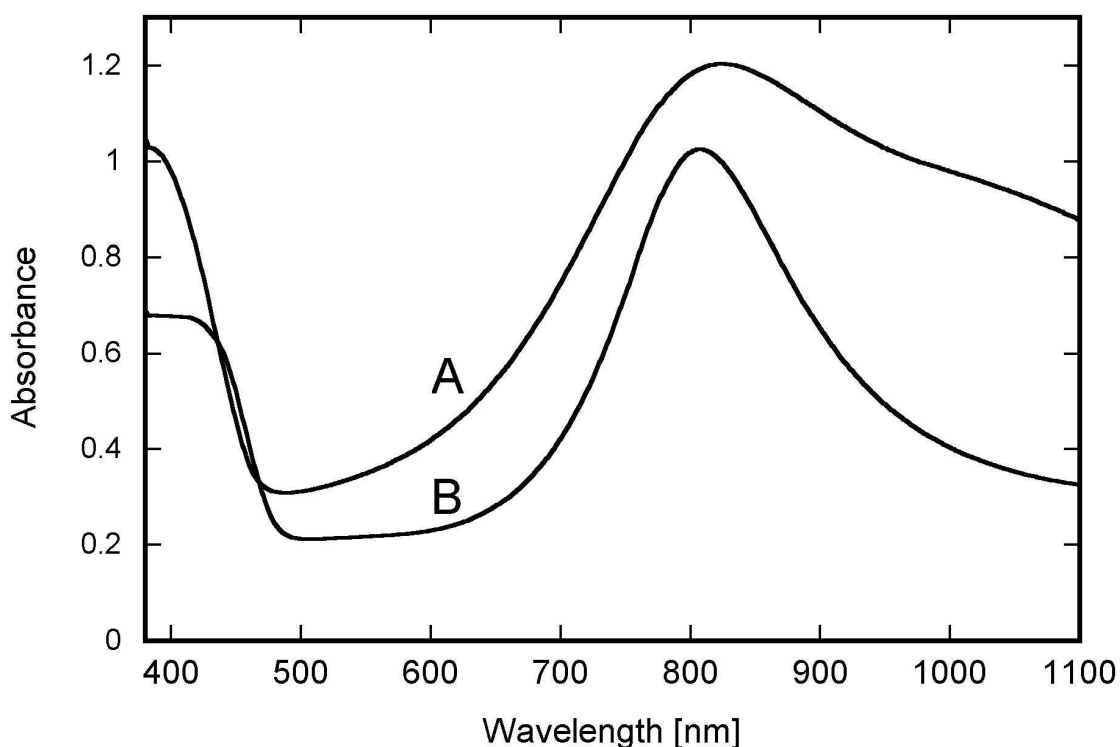

Fig. IV.6.1 UV-Vis-NIR spectra of poly(2-ethylaniline) (A) and polyanisidine (B) doped with dichloro(acetylacetonato) aluminium(III) in nitromethane

In the ^{27}Al NMR spectrum of polyanisidine complexed with $\text{AlCl}_2(\text{acac})$ in NM (fig. IV.6.2) two narrow signals at 104,8 ppm and 2,6 ppm can be distinguished. Additionally, a broad band with a maximum near 30 ppm can be noticed, suggesting that other, than two principal aluminium containing species, can be present in small quantities.

The signal at 104,8 ppm originates from the presence of AlCl_4^- anions in the doped polymer (see chapter IV.5). The second line at 2,6 ppm is located in the chemical shift range characteristic of the $\text{Al}(\text{acac})_3$ complex. It is known, that $\text{Al}(\text{acac})_3$ dissolved in *benzene* is frequently used as a reference in ^{27}Al NMR spectroscopy (thus its signal appears at $\delta = 0,0$ ppm).

To verify the solvent influence on the chemical shift of Al in $\text{Al}(\text{acac})_3$, we have registered its spectrum in *nitromethane*. In this solvent $\text{Al}(\text{acac})_3$ gives rise to one narrow line at $\delta = 1,4$ ppm. Close similarities in the chemical shift values in both spectra seems to indicate that $\text{Al}(\text{acac})_3$ is the second aluminium compound in $\text{AlCl}_2(\text{acac})$ doped polyanisidine, detectable by NMR.

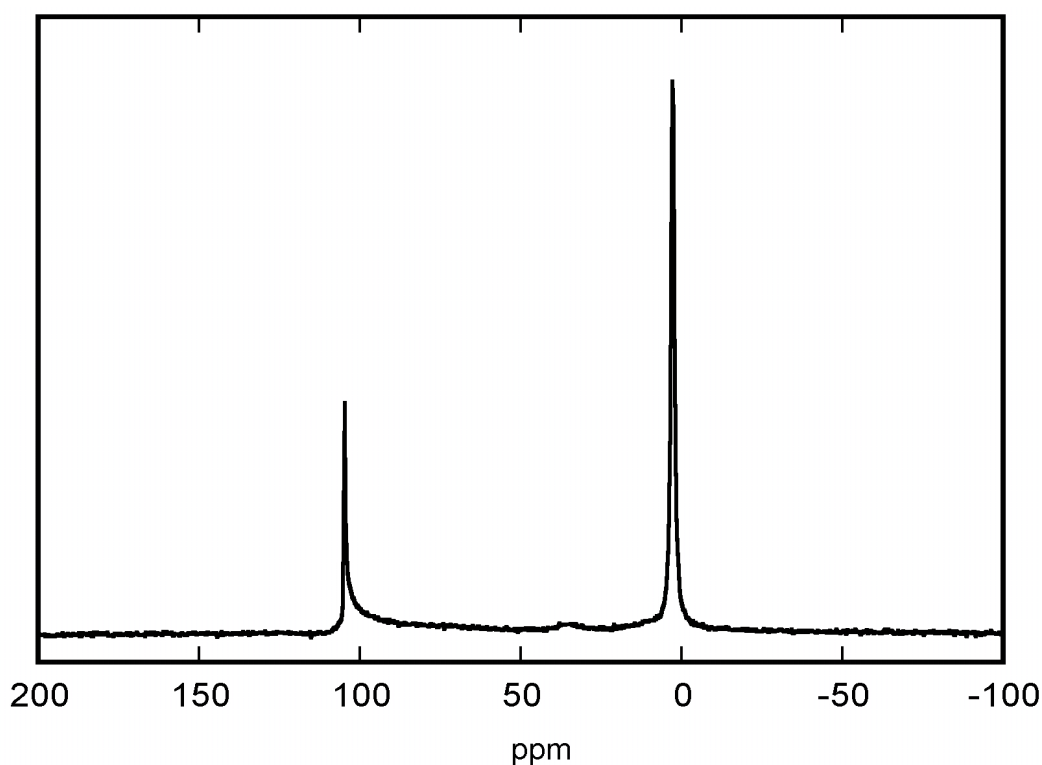

Fig. IV.6.2 ^{27}Al NMR spectrum of polyanisidine doped with $\text{AlCl}_2(\text{acac})$ in $\text{CH}_3\text{NO}_2/\text{CD}_3\text{NO}_2$ (4:1) registered at room temperature

The spectrum of doped polyanisidine is also significantly different from that registered by Lewinski et al. [85] for pure $\text{AlCl}_2(\text{acac})$, which consists of three peaks at

102, 88 and 37 ppm [*]. These authors propose the following dissociation equilibrium that occurs in the solution and ascribe the line at 102 ppm to AlCl_4^- moiety, the peak at 88 ppm to monomeric $\text{AlCl}_2(\text{acac})$ and a broad band centred at 37 ppm to a trimeric cation $[\text{Cl}_2\text{Al}_2(\text{acac})_3]^+$ (fig.IV.6.3).

It is clear that upon the doping of polyanisidine only AlCl_4^- is retained, the other aluminium species being transformed.

Based on the presented above spectroscopic data, the following reaction associated with the polymer doping can be proposed (eq.IV.6).

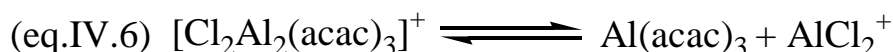

Polyanisidine, which shows high affinity to acidic molecules causes the transformation of $[\text{Cl}_2\text{Al}_2(\text{acac})_3]^+$ to a less bulky AlCl_2^+ cation, which can be easily complexed in imine sites of the polymer chain, while AlCl_4^- acts as a counter-ion (fig. IV.6.3). Simultaneously, stable hexacoordinated $\text{Al}(\text{acac})_3$ complex, formed as a side product. The cationic form of aluminium complex, coordinated on imine nitrogens is not detectable by ^{27}Al NMR, for reasons already described in chapter IV.5.

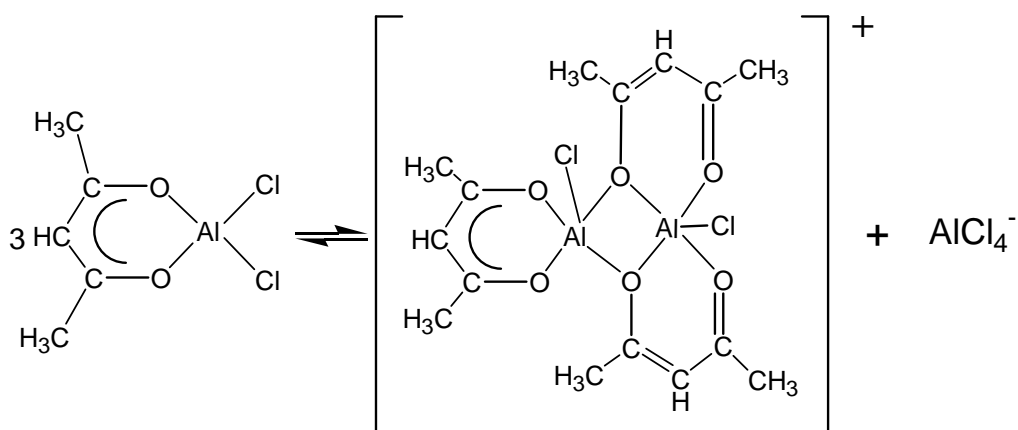

Fig.IV.6.3 Dissociation of monomeric $\text{AlCl}_2(\text{acac})$

The process of the doping is schematically depicted in fig.IV.6.4. The presence of the solvating nitromethane molecules is postulated by analogy with the AlCl_3 doping case.

[*] A very weak peak at ca. 3 ppm is also noticeable in this spectrum. The authors did not assigned this signal to any particular structure, but it may be postulated that this line originates from small amounts of $\text{Al}(\text{acac})_3$ which has been used as a substrate in the synthesis of $\text{AlCl}_2(\text{acac})$.

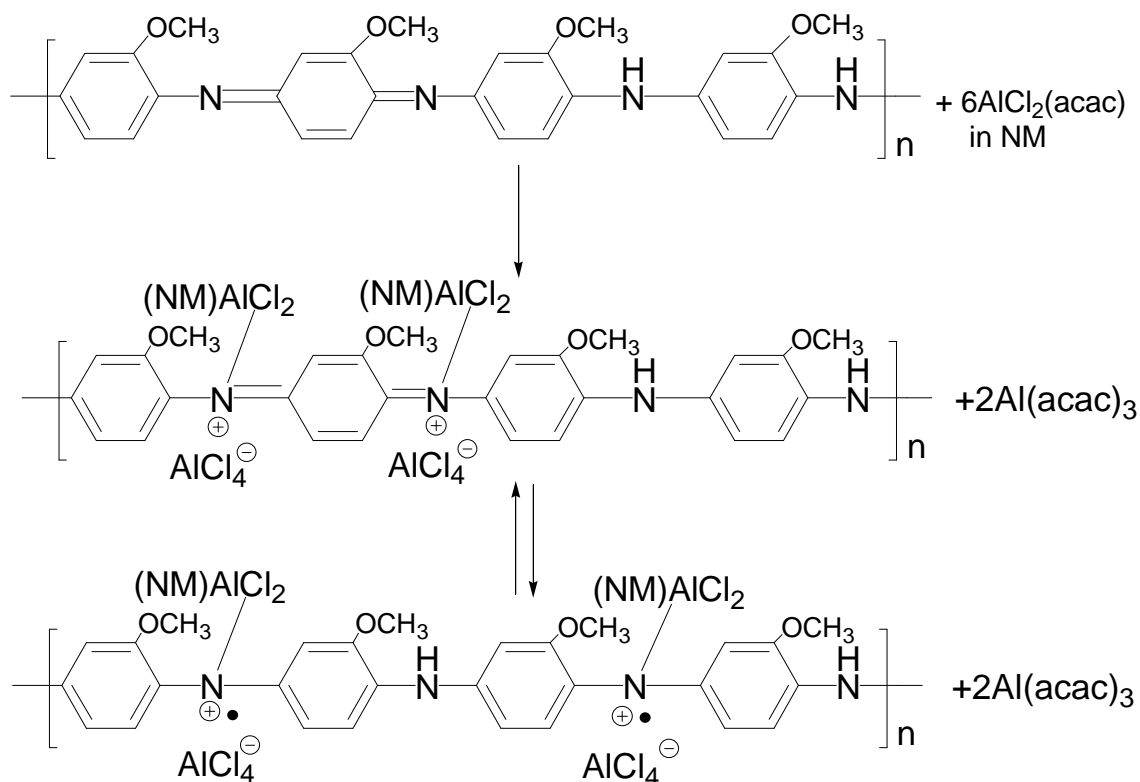

Fig. IV.6.4 Doping of polyanisidine with $\text{AlCl}_2(\text{acac})$ in nitromethane

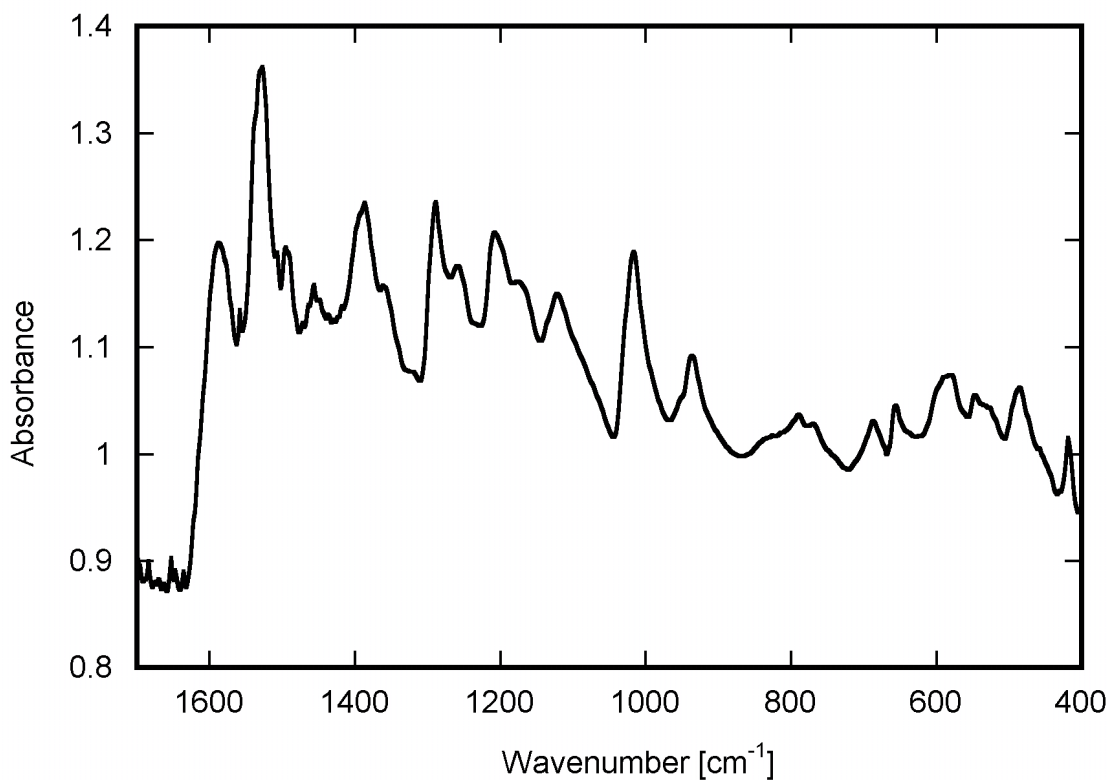

Fig. IV.6.5 IR spectrum ($400 \text{ cm}^{-1} - 1700 \text{ cm}^{-1}$) of polyanisidine doped with $\text{AlCl}_2(\text{acac})$ in nitromethane

A typical infrared spectrum was measured for polyanisidine doped with $\text{AlCl}_2(\text{acac})$ is presented in fig. IV.6.5. As expected, it is composed of bands characteristic of doped polyanisidine (*vide infra*) as well as bands originating from aluminium-acetylacetonato complexes. The bands are presented in table 4.6.1. Bands typical for $\text{Al}(\text{acac})_3$ compound are marked (X).

Wave number [cm^{-1}]	Vibration type
1582	C=C stretch in a quinoid ring
1492	C-C stretch in a benzenoid ring +C-H mixed vib.
1457	C-H mixed vib.-(X)
1386	C-C stretch in a quinoid ring + C-H bending in a benzenoid ring
1290	C-O stretch - (X)
1259	C-O stretch
1208	C-N stretch + C-H bending in a benzenoid ring
1120	Deformational of aromatic ring + C-H bending
1016	C-O stretch
930	C-O stretch -(X)
788	Deformational C-H (out of plane) of aromatic ring

Table 4.6.1 IR vibrational modes of polyanisidine doped with $\text{AlCl}_2(\text{acac})$

At the end, it should be stated that the chemical nature of the polymers doped with AlCl_3 and $\text{AlCl}_2(\text{acac})$ is very similar. In both cases AlCl_2^+ cations are complexed on imine nitrogens of the polymer chain whereas AlCl_4^- anions neutralise the positive charge of the polymer chain. The main difference consists of the fact that in the $\text{AlCl}_2(\text{acac})$ doping, $\text{Al}(\text{acac})_3$ is additionally incorporated to the solid polymer matrix. Note also, that, according to the scheme presented in fig.IV.6.3, a 50% excess of $\text{AlCl}_2(\text{acac})$ with respect to anisidine mer is required to assure complete doping of the polymer i.e. to complex all its imine nitrogens. We have used 1:1 mole ratio, which means that the real doping level of the samples described in this chapter is 67%.

V CONCLUSIONS

The doping of polymers from the polyaniline family with FeCl_3 and AlCl_3 as well as with their derivatives containing mixed chloride-acetylacetonate ligands were studied. The obtained results allow formulation of the following conclusions:

- Lewis acid doping of polyaniline and its derivatives involves self-dissociation of the dopant molecule. The cationic product of this self-dissociation is then complexed on the imine nitrogen sites of the polymer chain whereas the anionic part is incorporated to the polymer matrix in order to compensate the charge imposed on the polymer chain. The coordination sphere of the cationic complex is completed by solvation with a nitromethane molecule. This mechanism is different from that proposed in literature, however it better explains the electronic properties of doped polyanilines and is fully consistent with the results of complementary spectroscopic techniques such as NMR, EPR, Mössbauer, UV-Vis-NIR and IR.
- Treatment of FeCl_3 doped polyaniline with hexafluoroacetylacetone (HFAA) transforms it into the Brönsted acid (HFeCl_4) doped polymer and in the same time plasticizes it improving its mechanical properties.
- Although unable to dope polyaniline, dichloro(acetylacetonato)aluminum(III) dopes its ring substitute derivatives (polyanisidine and poly(2-ethylaniline)). The doping process is, in this case, accompanied by parallel reactions. The resulting product can be considered as AlCl_3 doped polymer with $\text{Al}(\text{acac})_3$ molecules incorporated to the polymer matrix as evidence by the results of complementary spectroscopic techniques (NMR, EPR, UV-vis-NIR)
- Polyanisidine and poly(2-ethylaniline) can also be doped with chloro bis-acetylacetonato iron (III) ($\text{FeCl}(\text{acac})_2$). The doping reaction is more complex than in other cases studied. Although the UV-vis-NIR spectroscopy unequivocally shows that the polymer chains are transformed into poly(radical-cations) characteristic of the doped state, the Mössbauer spectroscopy clearly indicates that more than two expected non-equivalent iron sites are formed upon the doping reaction.

VI APPENDIX A – PRINCIPLES OF THE MÖSSBAUER EFFECT SPECTROSCOPY

VI.1 INTRODUCTION

Rudolph Mössbauer discovered the nuclear gamma resonance in 1957. Its application in the case of the isotope ^{57}Fe of iron is certainly the most widely used, especially in investigation of chemical problems [83].

Nucleus is able to absorb and emit photons as well as whole atom. In the first case, the distance between the energy levels is much larger than in the second one. Nucleus excitation does take place when high-energy photons are used, namely gamma photons. Resonant absorption of the gamma rays is not possible in the conditions that are suitable for infrared photons (atom's absorption). It is caused by the fact that for nucleus resonance recoil effect could not be neglected.

According to Heisenberg uncertainty principle, the minimum full width of the resonant line at half height (Γ_H) is determined by mean life of the nuclear excited state (τ) emitting gamma rays:

$$\Gamma_H = \frac{h/2\pi}{\tau}$$

Mean life of excited state of ^{57}Fe is of the order of 10^{-9} seconds, so Γ_H is of the order of 10^{-9} eV. Thus, the line width is infinitesimal compared to transition energy $E_\gamma=14,4$ keV, and $\Gamma_H/ E_\gamma \approx 10^{-13}$. This coefficient determines theoretical sensitivity of the Mössbauer experiments.

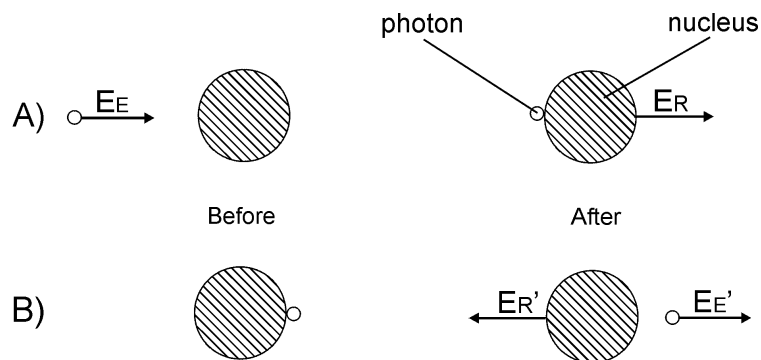

Fig. VI.1.1 Absorption (A) and emission (B) of γ photon having energy E_E , ($E_{E'}$) by a nucleus. E_R and ($E_{R'}$) are recoil energies.

By comparison, in the ultraviolet region, Γ_H/ E_γ are of the order 10^{-8} eV.

On emission (or absorption) of any photon the nucleus recoils (fig. VI.1.1). Recoil energy E_R is proportional to the energy which was emitted (or absorbed) by the nucleus E_E , and for gamma rays is $\sim 10^{-2}\text{eV}$. These energies are much larger than the line widths calculated above ($E_R \gg \Gamma_H$), and they cannot be neglected (as in the case of IR, or UV spectroscopies, where $E_R \ll \Gamma_H$). Under such circumstances, absorber and emitter energies do not overlap, and it seemed technically very difficult to make up for this energy loss.

At the moment of emission (or absorption) of gamma quantum, emitting nucleus has a velocity V_n (due to random thermal motion of atoms). Kinetic energy of the gamma quantum is dependent on the V_n . This is denoted as Doppler term E_D . At room temperature usually Doppler energies for high-energy photons are several orders bigger than Γ_H ; it results in a substantial thermal broadening of the lines. In these conditions resonance is possible, but only in the region A (fig. VI.1.2)

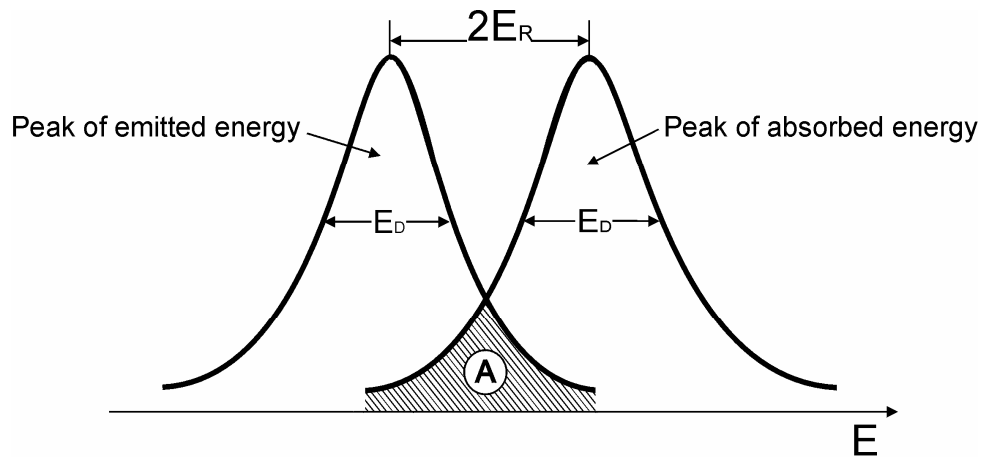

Fig. VI.1.2 Gamma photon absorption and emission energy distributions for free nucleus when recoil effect is observed. A – resonance area

Rudolph Mössbauer found, when studying nuclear resonant absorption using ^{191}Ir , that at low temperatures, for some low energy γ rays, resonance is more intense than at higher temperatures. Moreover, source and absorber peaks coincide completely, and due to low temperature, observed line widths at half height are close to those theoretically calculated.

Mössbauer spectroscopy is based on the nuclear gamma resonance with no recoil. The resonant nucleus is placed in solid-state matrix and recoil energy could be then transmitted to whole crystal. The crystal can only be excited in a quantized way with absorbing 0,1,2,3... phonons of energy $h\nu$. When exciting (recoil) energy is low enough ($E_R < h\nu$), 0 phonons is transferred from the nucleus to the matrix, then the crystal will not

be excited and emitting atom will effectively not recoil. Phonons emission increases in higher temperatures, so Mössbauer effect is more probable when freezing sample. This probability is known as a Mössbauer coefficient f :

$$f = \frac{L_N}{L}$$

Where: L_N -quantity of photons emitted with no recoil; L -sum of all photons emitted.

VI.2 APPLICATION OF DOPPLER EFFECT IN MÖSSBAUER SPECTROSCOPY

As in the majority of spectroscopies, in Mössbauer spectroscopy it is necessary to utilise source that is able to emit in an adequate domain continuous energy spectrum (to have possibility to modulate the energy beam). Considering the fact that nucleus resonant energies are gigantic comparing to the energies of the hyperfine interactions (*vide infra*) it is convenient to obtain this spectrum by moving the source, thus modulating the energy via the Doppler effect.

VI.3 MÖSSBAUER PARAMETERS

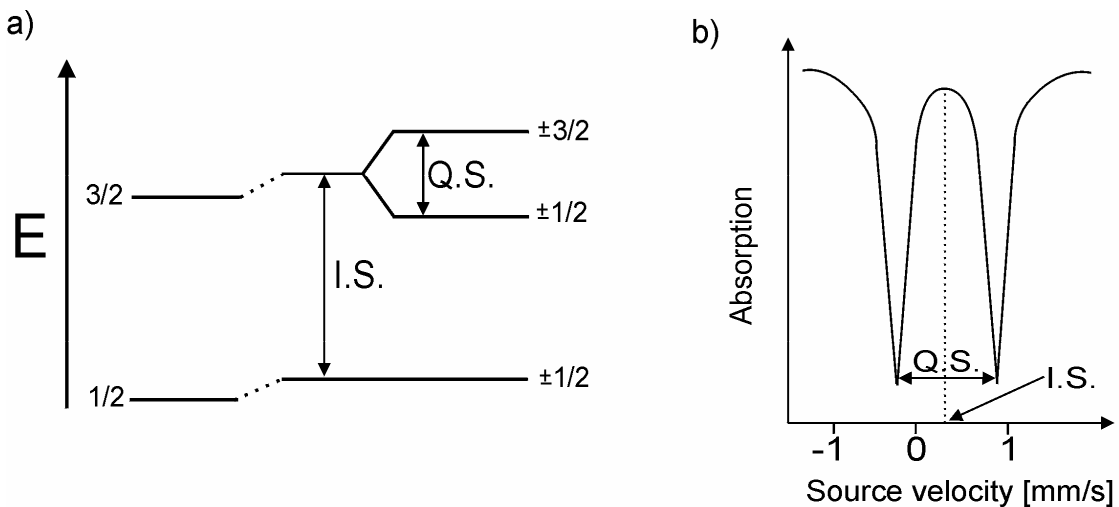

Fig..VI.3.1 a) Energy levels in sample (absorber), b) Corresponding Mössbauer spectrum

a) The Isomer Shift

Electrostatic interactions between charge distributed in the nucleus and electrons that can be found near the nucleus (s-orbital electrons) have an influence on nuclear energy levels. Magnitude of this influence is dependent on the overlapping degree of s-orbitals and nuclear charge. In the case where the external electric field does not split the nuclear energy levels, the difference between resonant energies for nuclei in the

emitter and in the absorber (sample) is represented in Mössbauer spectrum as an isomer shift (I.S.)(fig.VI.3.1). If no other hyperfine interactions are present, the observed signal will be composed of one line at the energy corresponding to that difference:

$$I.S. = K(R_e^2 - R_g^2)[|\psi_a(0)|^2 - |\psi_s(0)|^2]$$

where: K – nuclear constant, R_e – nucleus radius in excited state, R_g – nucleus radius in ground state, $|\psi_a(0)|$ - function describing s-electron density at the absorbing nucleus, $|\psi_s(0)|$ - function describing s-electron density at the emitting nucleus.

Due to the fact that valence orbitals (i.e. p and d) changes the s -electron density close to nucleus by screening effect, isomer shift can be useful to determine valency and oxidation state of Mössbauer atom.

Since I.S. is a relative value (various types of sources are in utilisation), it is extremely important to provide the information concerning the reference. In ^{57}Fe Mössbauer effect studies, the I.S. values are generally given with respect to metallic iron.

b) Quadrupole splitting

For a nucleus of spin $I > 1/2$, interaction between non-cubic extranuclear electric fields (so giving rise to an electric field gradient at the nucleus) and the asymmetric charge density of the nucleus results in a degeneration of nuclear energy levels. Electric field gradient can be the result of either non-equivalent ligand environment or valence electrons distribution. Due to this fact, Q.S. value provides important information about electron asymmetry in nuclei neighbourhood.

For instance, for ^{57}Fe spins are $3/2$ and $1/2$, in the excited and in the ground states, respectively (fig.IV.3.1a). Degeneracy of the excited level is partially removed by the electric field gradient, and two transitions are allowed, both equally probable. So two lines with the same intensities are observed. Quadrupole splitting is defined as a difference in energies between these lines (fig.IV.3.1b). In such situation, I.S. is placed in half of the distance between terminal lines in the multiplet. When both ground and excited states have spin values bigger than $1/2$ (as for ^{129}I) more transitions are allowed and, in consequence, more complicated spectra are obtained.

c) Magnetic splitting (hyperfine interactions)

If magnetic field is present, magnetic dipole moment of each nucleus interacts with this field. In such situation, degeneracy of energy levels is totally removed.

Magnetic field can be either applied (external) or local (internal). In the case of ^{57}Fe isotope, and when magnetic moments are randomly oriented, these interactions cause arising to a six-line spectrum with relative intensities 3:2:1:1:2:3 (given by quantum mechanics rules). If we are not in random case, intensity of whole sextet is dependent on the angle between effective magnetic field and the propagation of γ radiation.

VI.4 BASIC MÖSSBAUER EQUIPMENT

Scheme of the Mössbauer spectroscopy equipment [131] is shown on figure VI.4.1.

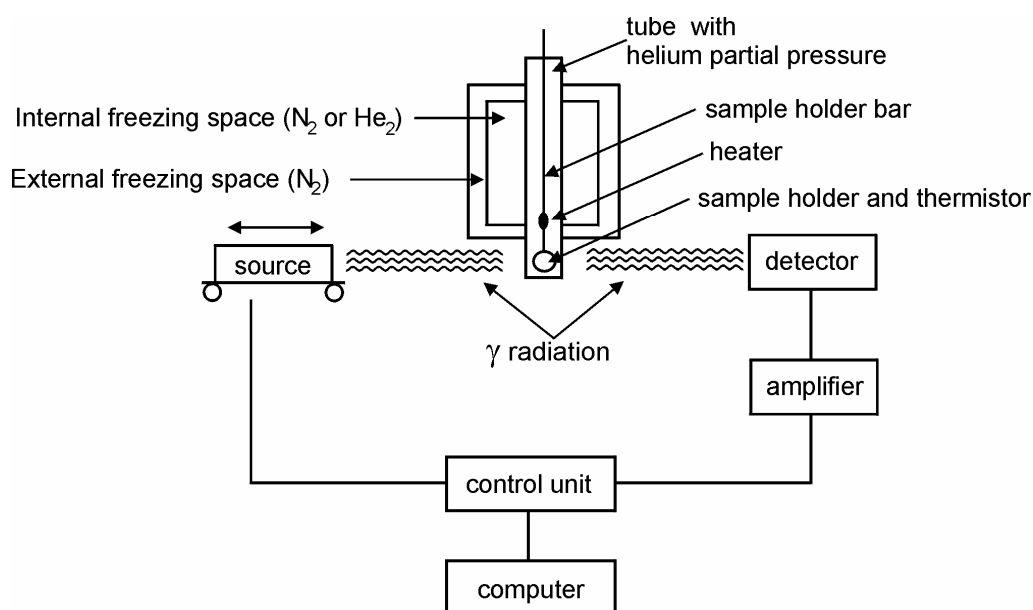

Fig.VI.4.1 Block scheme of Mössbauer spectrometer

The sample is placed in a cryostat, in the space that is under vacuum with helium partial pressure. Presence of the gas allows energy exchange. The cryostat has two freezing spaces. When performing measurements between 77K and room temperature, both spaces are filled with liquid nitrogen. When performing experiments below 77K, external space is filled with liquid nitrogen, and internal one with liquid helium. Thermistor placed close to sample holder is used to the temperature control. Thanks a small heater on a sample holder bar it is possible to obtain any temperature of the experiment.

Radioactive material (i.e. ^{57}Co in cubic Rhodium matrix), is placed on vibration device, that is connected, as well as gamma radiation detector (via amplifier), to the control unit. This construction allows applying well-controlled velocity to the source, and analyses signal at detector input in function of the energy. Computer coupled with the control unit registers the spectra.

VII SUMMARY

The presented research is devoted to the studies of the doping of polyaniline and its ring substituted derivatives (polyaniline, poly(2-ethylaniline)) with AlCl_3 and FeCl_3 as well as with their derivatives containing mixed chloride - acetylacetonate ligands ($\text{AlCl}_2(\text{acac})$ and $(\text{FeCl}(\text{acac})_2)$). AlCl_3 and FeCl_3 doped polymers are conductive and show the electronic type conductivity of the order 10^{-3} S/cm. Complementary spectroscopic studies involving UV-Vis-NIR, IR, EPR, ^{27}Al NMR (in the case of AlCl_3 doping) and ^{57}Fe Mössbauer effect (in the case of FeCl_3 doping), combined with elemental analysis, enabled us to elucidate the doping reaction mechanism, which in both cases is the same. The doping involves, in the first step, the self-dissociation of the dopant molecule. The cationic product of this self-dissociation is the complexed on imine nitrogen sites of the polymer chain, whereas the anionic part is incorporated into the polymer matrix to neutralise the positive charge imposed on the polymer chain. The coordination sphere of the cationic complex is completed by solvation with a nitromethane molecule. Charge rearrangement accompanying the doping process produces mobile radical cations on the polymer chain, which assure electronic conductivity of the doped polymer. This mechanism clearly explains the presence of charge carriers and the radical cation structure of the doped polymer chain detected by EPR and UV-Vis-NIR spectroscopies. FeCl_3 doped polyaniline shows poor mechanical properties, which can however, be improved by post-treatment with hexafluoroacetylacetone (HFAA). This treatment results in the transformation of FeCl_3 (Lewis acid) doped polyaniline into HFeCl_4 (Brönsted acid) doped polymer, simultaneously plasticized with HFAA. Doping with mixed ligands ($\text{AlCl}_2(\text{acac})$ and $(\text{FeCl}(\text{acac})_2)$), although being inactive with respect to polyaniline doping, readily dope polyaniline and poly(2-ethylaniline). The chains of doped polymers adopt the radical cation structure as evidenced by UV-Vis-NIR spectroscopy, however the doping mechanism is more complex than in the case of reaction with AlCl_3 or FeCl_3 . The doping with $\text{AlCl}_2(\text{acac})$ results in the AlCl_3 doped polymer with $\text{Al}(\text{acac})_3$ incorporated to the polymer matrix as a side reaction product. Doping with $\text{FeCl}(\text{acac})_2$ produces more than expected non-equivalent iron sites of the chemical constitution not easily identifiable by Mössbauer spectroscopy.

VIII RESUME

Ce travail est consacré à l'étude du dopage de la polyaniline et de ses dérivés substitués (polyanisidine, poly(2-éthylaniline)) avec d'une part le chlorure d'aluminium AlCl_3 ou le chlorure ferrique FeCl_3 , d'autre part avec leurs dérivés contenant les ligands mixtes chlorure-acétylacétonate ($\text{AlCl}_2(\text{acac})$ ou $(\text{FeCl}(\text{acac})_2)$). Les polymères dopés avec AlCl_3 ou FeCl_3 sont conducteurs, et leur conductivité électronique est de l'ordre de 10^{-3} S/cm. Des études spectroscopiques complémentaires (UV-VIS-Proche IR, IRTF, RPE, RMN du noyau ^{27}Al (dans le cas du dopage avec AlCl_3) et spectroscopie Mössbauer sur le noyau ^{57}Fe (dans le cas du dopage avec FeCl_3)), combinées avec l'analyse élémentaire, permettent de comprendre et d'identifier un même mécanisme de dopage. Celui-ci correspond en un premier temps à une dissociation de la molécule du dopant. La partie cationique résultant de cette dissociation est complexée sur les sites azote de type imine de la chaîne du polymère, tandis que la partie anionique s'incorpore à la matrice polymère afin de neutraliser la charge positive imposée à la chaîne du polymère. La sphère de coordination du complexe cationique est complétée par solvatation avec une molécule de nitrométhane. Le réarrangement des charges accompagnant le processus de dopage entraîne la création de radicaux cationiques mobiles sur la chaîne du polymère, donnant ainsi au polymère dopé des propriétés de conduction électronique. Ce mécanisme rend parfaitement compte de la présence de porteurs de charge et de la structure cationique des radicaux de la chaîne polymérique dopée mises en évidence par les expériences de spectroscopie RPE et d'absorption UV-VIS-Proche IR. La polyaniline dopée avec FeCl_3 présente de faibles propriétés mécaniques, qui peuvent cependant être améliorées par un traitement ultérieur avec l'hexafluoroacétylacétonate (HFAA). Ce traitement conduit à la transformation de la polyaniline dopée avec FeCl_3 (acide de Lewis) en un polymère dopé avec HFeCl_4 (acide de Brønsted), simultanément plastifié par HFAA. Le dopage avec les ligands mixtes ($\text{AlCl}_2(\text{acac})$ ou $(\text{FeCl}(\text{acac})_2)$), bien qu'inopérant en ce qui concerne la polyaniline, conduit clairement au dopage de la polyanisidine et de la poly(2-éthylaniline). Les chaînes de ces polymères dopés présentent une structure radicalaire cationique mise en évidence par les expériences d'absorption UV-VIS-Proche IR ; mais le mécanisme de dopage reste plus complexe à définir que dans le cas du dopage avec AlCl_3 ou FeCl_3 . Le dopage avec $\text{AlCl}_2(\text{acac})$ conduit à un polymère dopé avec AlCl_3 avec $\text{Al}(\text{acac})_3$ incorporé à la matrice du polymère comme sous-produit. Le dopage avec $\text{FeCl}(\text{acac})_2$ donne un composé présentant davantage de sites de fer non équivalents qu'il en est attendu ; leur nature reste difficile à identifier par spectrométrie Mössbauer.

IX STRESZCZENIE

Powyższa praca jest poświęcona badaniom domieszkowania polianiliny i jej pochodnych podstawionych w pierścieniu aromatycznym (polianizydyny, poli(2-etyloaniliny) chlorkami żelaza (III) i glinu (III), a także pochodnymi tych chlorków zawierającymi ligandy acetyloacetonianowe (acac) – $\text{AlCl}_2(\text{acac})$ i $\text{FeCl}(\text{acac})_2$. Polimery domieszkowane AlCl_3 i FeCl_3 wykazują przewodnictwo elektryczne rzędu 10^{-3} S/cm. Badania spektroskopowe spektroskopii UV-Vis-NIR, FTIR, EPR, ^{27}Al NMR (w przypadku domieszkowania związkami glinu) i badania spektroskopowe spektroskopii Mössbauera dla jąder ^{57}Fe (w przypadku domieszkowania związkami żelaza) umożliwiają wyjaśnienie mechanizmu reakcji domieszkowania. Wyniki uzyskane dla FeCl_3 i AlCl_3 sugerują ten sam mechanizm reakcji dla obydwu związków. W pierwszym etapie procesu domieszkowania cząsteczki domieszki autodysocjują. Kationy powstałe w wyniku tej autodysocjacji kompleksują grupy iminowe łańcucha polimerowego, podczas gdy aniony zostają wbudowane do matrycy polimerowej kompensując ładunek. W sferze koordynacyjnej kompleksu kation-polimer znajduje się także cząsteczka rozpuszczalnika – nitrometanu. Przegrupowanie ładunku mające miejsce podczas reakcji domieszkowania jest odpowiedzialne za wytworzenie mobilnych kationorodników, dzięki czemu polimer przewodzi elektronowo. Powyższy mechanizm wyjaśnia obecność nośników ładunku i strukturę kationorodnikową wykrytą metodami EPR i UV-Vis-NIR. Polianilina domieszkowana FeCl_3 ma słabe właściwości mechaniczne, które ulegają poprawie po dodaniu heksafluoroacetyloacetonu do układu. Po dodaniu HFAA zachodzi reakcja, w wyniku której polimer domieszkowany kwasem Lewisa (FeCl_3) jest przetwarzany w polimer domieszkowany kwasem Brönsteda (HFeCl_4). Równolegle HFAA pełni rolę plastyfikatora. Związki posiadające mieszane ligandy ($\text{FeCl}(\text{acac})_2$ i $\text{AlCl}_2(\text{acac})$) nie reagują z polianiliną domieszkując równocześnie jej pochodne – polianizydynę i poli(2-etyloanilinę). Widma UV-Vis-NIR wskazują, że forma kationowa domieszkuje łańcuch polimerowy; niemniej jednak mechanizm tych reakcji jest bardziej złożony niż w przypadku chlorków żelaza i glinu. W wyniku domieszkowania polimeru kompleksem $\text{AlCl}_2(\text{acac})$ otrzymuje się polimer domieszkowany AlCl_3 i $\text{Al}(\text{acac})_3$ jako produkt uboczny wbudowany w matrycę polimerową. Produkt domieszkowania polimeru $\text{FeCl}(\text{acac})_2$ daje złożone widmo efektu Mössbauera, co powoduje trudności w identyfikacji związków obecnych

w

próbce.

X REFERENCES

1. J. Fritzsche, *J. Prakt. Chem.* **20** (1840) 453
2. H. Latheby, *J. Chem. Soc.* **15** (1862)
3. R. De Surville, M Jozefowicz, L.T. Yu, J. Perichon, R. Buvet, *Electrochim. Acta* **13** (1968) 1451
4. A. Proń, P. Rannou, *Prog. Polym Sci.* **27** (2002) 135
5. Y. Cao, P. Smith, A.J. Heeger *Synth. Met.* **48** (1992) 91
6. A. Pron, J.E Österholm, P. Smith, A.J. Heeger, J. Laska, M. Zagorska, *Synth. Met.* **55-57** (1993) 3520
7. I. Kulszewicz-Bajer, M. Zagorska, J. Niziol, A. Pron, W. Luzny *Synth Met.* **114** (2000) 125
8. H.S.O. Chan, S.C. Ng, *Macromolecules* **27** (1994) 2159
9. O.T. Ikkala, L-O Pietilä, L. Ahjopalo, H. Österholm, P.J. Passiniemi, *J. Chem. Phys* **103** (1995) 9855
10. R.K. Paul, C.K.S. Pillai, *Synth. Met.* **114** (2000) 27
11. T.E. Olinga, J. Fraysse, J.P. Travers, A Dufresne, A. Proń, *Macromolecules* **33** (2000) 2107)
12. C.J. Yang, S.A. Jenekhe, *Chem. Mater.* **3** (1991) 878
13. I. Kulszewicz-Bajer, A. Pron, J. Abramowicz, C. Jeandey, J-L Oddou, J.W. Sobczak, *Chem. Mater.* **11** (1999) 552
14. F. Genoud, I. Kulszewicz-Bajer, A. Bedel, J-L Oddou, C. Jeandey, A. Pron, *Chem. Mater.* **12** (2000) 744
15. D. Haudhuri, A. Kumar, I. Rudra, D. Sarma, *Adv. Mater.* **13** (2001) 1548
16. J.J. Coquillon, *Compt. Rend.* **81** (1875) 408)
17. R. Willstater, J. Cramer, *Ber.* **43** (1910) 2976
18. A.G. Green, A.E. Woodhead, *J.Chem. Soc.* **97** (1910) 2388
19. A.G. Green, A.E. Woodhead, *Ber.* **45** (1912) 1955
20. A.F. Diaz, J.A. Logan, *J. Electroanal. Chem.* **111** (1980)
21. A.G. MacDiarmid, J. C. Chiang, M. Halpern, W.S. Huang, J.R. Krawczyk, R.J. Mammone, S.L. Mu, N.L.D. Somarisi, W. Wu, *Polym. Prepr.* **24** (1984) 248
22. F.L. Lu, F. Wudl, M. Nowak, A.J. Heeger, *J. Am. Chem. Soc.* **108** (1986) 8311

-
23. D.J. Vachon, R.O. Angus, F.L. Lu, M. Nowak, Z.X. Liu, H. Schaffer, F. Wudl, A.J. Heeger, *Synth. Met.* **17-19** (1987) 297
24. A.Ray, G.E. Asturias, D.L. Kershner, A.F. Richter, A.G. MacDiarmid, A.J. Epstein, *Synth. Met.* **29** (1989) E141
25. A.G. MacDiarmid, A.J. Epstein, *Faraday Discuss. Chem. Soc.* **88** (1989) 317
26. W. Zheng, M. Angelopoulos, A.J. Epstein, A.G. MacDiarmid, *Macromolecules* **30** (1997) 2953
27. Y-H. Liao, T.K. Kwei, K. Lewon, *Macromol. Chem. Phys.* **96** (1995) 3107
28. A. Boyle, J-P. Penneau, E. Genies, C. Riekiel, *J. Polym. Sci., Part B: Polym. Physics* **30** (1992) 265
29. P.N Adams, P.J. Laughlin, A.P. Monkman, A.M. Kenwright, *Polymer* **37 (15)** (1996) 3411
30. A. Proń, F. Genoud, C. Menadro, M. Nechtschein, *Synth. Met.* **25** (1988) 193
31. J.E. Österholm, Y. Cao, F.L. Klavetter, P. Smith, *Synth. Met.* **55** (1993) 1034
32. L. A. Samuelson, A. Anagnostopoulos, K. Alva, J. Kumar, S.K. Tripathy, *Macromolecules* **31** (1998) 4376
33. D.M. Mohilner, R.N. Adams, W.J. Argersinger Jr. *J. Am. Chem. Soc.* **84** (1962) 3618
34. E.M. Genies, C. Tsintavis, *J. Electroanal. Chem.* **195** (1985) 109
35. E.M. Genies, M. Łapkowski, *J. Electroanal. Chem.* **236** (1987) 199
36. T. Kobayashi, H. Yoneyama, H. Tamura, *J. Electroanal. Chem.* **177** (1984) 293
37. B. Wang, J. Tang, F. Wang, *Synth. Met.* **13** (1986) 329
38. A. Watanabe, K. Mori, M. Mikuni, Y. Nakamura, M. Matsuda, *Macromol.* **22** (1989) 3323
39. K. Teshima, K. Yamada, N. Kobayashi, R.M. Hirohashi, *J. Electroanal. Chem.* **426** (1997) 97
40. M. Gholamian, A.Q. Contractor, *J. Electroanal. Chem.* **252** (1988) 291
41. H. Goto, K. Iino, K. Akagi, H. Shirakawa, *Synth. Met.* **85** (1997) 1683
42. M. Pomerantz, D.E. Mire, *Abstr. PAP Am. Chem.* S215 (1997) U424
43. T. Kanabara, K. Izumi, Y. Nakadami, T. Narise, K. Hasegawa, *Chem. Lett.* (1997) 1185
44. S.B. Kim, K. Harada, T. Yamamoto, *Macromolecules* **31** (1998) 988
45. M. Breitenbach, K.H. Heckner, *J. Electroanal. Chem.* **43** (1973) 267
46. G. Zotti, S. Catarin, N. Comisso, *J. Electroanal. Chem.* **239** (1988) 387
47. M. Takakubo, *Synth. Met.* **33** (1989) 19

-
48. Y. Wei, G.W. Jang, C.C. Chan, K.F. Hsueh, R. Hariharan, S.A. Patel, C.K. Whitecar, *J. Phys. Chem.* **94** (1990) 7716
49. I. Wielgus, *Ph.D. dissertation*, Warsaw University of Technology, 2000, p.13-14
50. M. Leclerc, J. Guay and L.H. Dao *Macromolecules* **22** (1989) 649
51. Y. Wei, W.W. Focke, G.E. Wnek, A. Ray, A.G. MacDiarmid, *J. Phys. Chem.* **93** (1993) 495
52. M. Leclerc, J. Guay, L.H. Dao, *J. Electroanal. Chem.* **251** (1988) 21
53. L.R.Sharma, A.K. Manchanda, G. Singh, R. Verma, *Electrochim. Acta* **27** (1982) 223
54. R. Willstater, C.W. Moore, *Chem. Ber.*, **40** (1907) 2665
55. E. Rebourt, J.A. Joule, A.P. Monkman, *Synth. Met.* **84** (1997) 65
56. J.P.Sadighi, R.A.Singer, S.L.Buchwald, *J.Am.Chem.Soc.* **120** (1998) 4960
57. J. Honzl, M. Tlustakova, *J. Polym Sci. C* **22** (1968) 451
58. W. Zhang, J. Feng, A.G. MacDiarmid, A.J. Epstein, *Synth. Met.* **84** (1997) 119
59. W.S. Huang, B.D. Humphrey, A.G. MacDiarmid, *J. Chem. Soc., Faraday Trans.* **82** (1986) 2358
60. F. Devreux, F. Genoud, M. Nechtshein, B. Villeret *Springer Ser. Solid-State Sci.* **76** (1987) 270
61. M.Ginder, A.F. Richter, A.G. MacDiarmid, A.J. Epstein *Bull. Am. Phys. Soc* **31** (1986) 582
62. F. Zuo, M. Angelopoulos, A.G. MacDiarmid, A.J. Epstein *Phys. Rev. B* **36** (1987) 3475
63. M.Y. Hua, G.W. Hwang, Y.H. Chuang, S.A. Chen, *Macromol.* **33** (2000) 6235
64. K. Levon, K.H. Ho, W.Y. Zheng, J. Laakso, T. Karna, T. Taka, *Polymer* **36** (1995) 2733
65. J.P. Pouget, C.H. Hsu, A.G. MacDiarmid, A.J. Epstein, *Synth. Met.* **69** (1995)119
66. A.G. MacDiarmid, A.J. Epstein, *Synth. Met.* **69** (1995) 85
67. W. Luzny, E. Banka, *Macromolecules* **33** (2000) 425
68. P.N. Adams, P. Devasagayam, S.J. Pomfret, L. Abell, A. Monkman, *J. Phys. Condens. Matter.* **10** (1998) 8293
69. A. Pron, J. Laska, J.E. Österholm, P. Smith, *Polymer* **34** (1993) 4230
70. J. Laska, A. Pron, S. Lefrant, *J. Polymer Sci. Part A: Polymer. Chem.* **33** (1995) 1437
71. A.V. Saprigin, K.R. Brenneman, W.P. Lee, S.M. Long, R.S. Kohlman, A.J. Epstein, *Synth. Met.* **100** (1996) 55
72. S.A. Chen, L.C. Liang, *Macromolecules* **28** (1995)1239

-
73. S.K. Manohar, A.G. MacDiarmid, K.R. Cromack, J.M. Ginder, A.J. Epstein, *Synth. Met.* **29** (1989) E349
74. Y. Xia, J.M. Wiesinger, A.G. MacDiarmid, A.J. Epstein *Chem. Mater.* **7** (1995) 443
75. A. Pron, P. Rannou, A. Gawlicka, I. Kulszewicz-Bajer, D. Berner, M. Nechtschein, D. Djurado, *Synth. Met.* **101** (1999) 729
76. M. Leclerc, G. d'Aprano, G. Zotti, *Synth. Met.* **55-57** (1993) 1527
77. J.A. Conklin, S.C. Huang, S.A. Huang, T. Wen, R.B. Kaner, *Macromolecules*, **25** (1995) 6522
78. G. d'Aprano, M. Leclerc, G. Zotti, G. Schiavon *Chem. Mater.* **7** (1995) 33
79. X.L. Wei, Y.Z. Wang, S.M. Long, C. Bobeczko, A.J. Epstein *J. Am. Chem. Soc.* **118** (1996) 2545
80. S. Quillard, G. Louarn, S. Lefrant, A.G. MacDiarmid *Phys. Rev. B*, **50** (1994) 12496
81. C.H. Choi, M. Kertesz, *Macromolecules*, **30** (1997) 620
82. Irena Kulszewicz-Bajer *Brönsted versus Lewis acid doping of polyaniline*, OWPW, Warszawa 2000
83. „Mössbauer Spectroscopy”, *Chapman and Hall Ltd. London, 1971*
84. M. Cox, B.W. Fitzsimmons, A.W. Smith, L. F. Larkworthy, K. A. Rogers, *J. Chem. Soc. (A)*, (1971) 2158
85. J. Lewiński, S. Pasynekiewicz, J. Lipkowski, *Inorganica Chimica Acta* **178** (1990) 113
86. Y. Cao, A. Andreata, A. J. Heeger, P. Smith, *Polymer* **30**, (1989) 2305
87. J.C. Chiang, A.G. MacDiarmid, *Synth. Met.* **13** (1986) 193
88. A.G. MacDiarmid, J.C. Chiang, A.F. Richter, A.J. Epstein, *Synth. Met.* **18** (1987) 285
89. W.W. Yau, J.J. Kirkland, D.D. Bly, *Modern size-exclusion liquid chromatography*, Wiley Interscience, New York, 1979
90. J.P. Pouget, M.E. Józefowicz, A.J. Epstein X. Tang, A.G. MacDiarmid, *Macromolecules* **24** (1991) 779
91. M.J. Winokur, B.R. Mattes, *Macromolecules* **31** (1998) 8183
92. M. Laridjani, A.J. Epstein, *Eur. Phys. J. B* **7** (1999) 585
93. A. Alix, V. Lemoin, M. Nechtschein, J.P. Travers C. Menardo, *Synthetic Metals* **29** (1989) E457-E462
94. B.Z. Lubentsov, O.N. Timofeeva, M.L. Khidekel, *Synth. Met.* **45** (1991) 235-240
95. W. Łużny, M. Śniechowski, J. Laska, *Synth. Met.* **126** (2002) 27-35
96. B.Z. Lubentsov, O.N. Timofeeva, M.L. Khidekel, *Synth. Met.* **45** (1991) 235-240

-
97. P. McCall, J.M.Ginder, J.M. Leng, H.J. Ye, S.K. Manohar, J.G. Masters, G.E. Asturias, A.G. MacDiarmid, A.J. Epstein *Phys. Rev. B, Cond. Matter.* **41(8)** (1990) 5202
98. S. Stafström, B.Sjögren, J.L. Brédas, *Synth. Met.* **29** (1989) E219
99. *Metody spektroskopowe i ich zastosowanie do identyfikacji związków organicznych*, WNT, Warszawa 1995 p.598-599
100. A. Pron, I. Kulszewicz, D. Billaud, J. Przyłuski *J. Chem. Soc. Chem. Comm.* (1981) 783
101. A. Proń, D.Billaud, I. Kulszewicz, C. Budrowski, J. Przyłuski *Mat. Res. Bull.* **16** (1981) 1229
102. A. Pron, M. Zagórska, Z. Kucharski, M. Lukasiak, J. Suwalski, *J. Mater. Res. Bull* **14** (1982) 1505
103. A. Proń, Z. Kucharski, C. Budrowski, M. Zagórska, S.Kirchene, J. Suwalski, G. Dehe, S. Lefrant, *J. Chem. Phys.* **83** (1985) 5923
104. F. Genoud, I. Kulszewicz-Bajer, B. Dufour, P. Rannou, A.Pron, *Synth. Met.* **119** (2001) 415
105. I. Kulszewicz-Bajer, J. Suwalski, *Synth. Met.* **119** (2001) 343
106. P.A.D. de Maine, E. Koubek, *J. Inorg Nucl. Chem.* **11** (1959) 329
107. Show-An Chen, Liang-Chang Lin, *Adv. Mater.* **7** (1995) 473
108. R.E Cameron, S.K. Clement, A.L. Landis, *Bull. Am. Phys. Soc.* **34** (1989) 582
109. R. Schlögl, W. Jones, *J. Chem. Soc. Dalton Trans.* (1984) 1283
110. P. Gutlich, R. Link, A. Trautwein “*Mössbauer Effect Spectroscopy and Transition Metal Chemistry*” Springer-Verlag (1978)
111. A. Proń, G.A. Fatseas, S. Kirchene, S. Lefrant, F. Maurice, G. Froyer, *Phys. Rev. B.* **32** (1985) 1839
112. F.A. Cotton, G. Wilkinson, „*Advanced Inorganic Chemistry*” John Willey and Sons, 5th edition (1988)
113. J. Suwalski, A. Pron and J. Kucharski, *Materials Science Forum* **21** (1987) 125
114. K. Bieńkowski, J-L. Oddou, O. Horner, I. Kulszewicz-Bajer, F. Genoud, J. Suwalski, A.Proń, *Nukleonika* **48** (2003) S3-S7
115. P.Fedorko, D.Djurado, M.Trznadel, B.Dufour, P.Rannou, J.P.Travers, *Synth. Met.* **135** (2003) 327
116. R. N. Haszeldine, W.K.R. Musgrave, F. Smith, L.M. Turtan, *J. Chem. Soc.* (1951) 609
117. C.Nicolini, J.Chappert, J.P. Mathieu, *Inorg. Chem.* **12** (1977) 3112

-
118. E. Houze, M. Nechtschein, A. Pron, *Phys. Rev. B* **56** (1997) 12263
119. M.L. Morris, R.W. Moshier, R.E. Sievers, *Inorg. Chem.* (1962) 411
120. M. Nechtschein, C. Santier, J.P. Travers, J. Chroboczek, A. Alix, M. Ripert, *Synth.Met.* **18** (1987) 311
121. C.D. Burbridge, D.M. Goodgame *J. Chem. Soc. (A)* (1968) 1410
122. J.W. Connolly, D.S. Dudis *Macromolecules* **27** (1994) 1423
123. M.F. Roberts, S.A Jenekhe, A. Cameron, M. McMillan, J. Perlstein, *J. Chem. Mater.* **6** (1994) 658
124. J.W. Connolly, D.S. Dudis, S. Kumar, L.T. Gelbaum, N. Venkatasubramanian, *Chem. Mater.* **8** (1996) 54
125. M. Dalibart, J. Derouault, P. Granger *Inorg. Chem.* **21** (1982) 2241
126. J.Lewiński, „*Encyclopedia of Spectroscopy and Spectrometry, Vol. 1, Magnetic Resonance: Heteronuclear NMR applications*”, ed. J. C.Lindon, G. E.Tranter, J. Holmes, Academic Press 1999
127. M. Dalibart, J. Derouault, P. Granger, S. Chapelle, *Inorg Chem* **21** (1982) 1040
128. J. Lewinski, J. Zachara, K.B. Starowieyski, Z.Ochal, I. Justyniak, T. Kopeć, P. Stolarzewicz, M. Dranka, *Organometallics* **22** (2003) 3773
129. E.Schippert *Adv. Mol. Relax. Proc.* **9** (1976) 167
130. Renaud Payerne *Ph.D. dissertation* , Universite Joseph Fourier- Grenoble I, November 2004, p 131
131. Jean-Louis Oddou, *Personal Communication*