



HAL
open science

Some applications of singularity theory to the geometry of curves and surfaces

Farid Tari

► **To cite this version:**

Farid Tari. Some applications of singularity theory to the geometry of curves and surfaces. Mathematics [math]. Liverpool University, 1990. English. NNT : . tel-00001916

HAL Id: tel-00001916

<https://theses.hal.science/tel-00001916>

Submitted on 4 Nov 2002

HAL is a multi-disciplinary open access archive for the deposit and dissemination of scientific research documents, whether they are published or not. The documents may come from teaching and research institutions in France or abroad, or from public or private research centers.

L'archive ouverte pluridisciplinaire **HAL**, est destinée au dépôt et à la diffusion de documents scientifiques de niveau recherche, publiés ou non, émanant des établissements d'enseignement et de recherche français ou étrangers, des laboratoires publics ou privés.

**SOME APPLICATIONS OF SINGULARITY THEORY
TO THE GEOMETRY OF CURVES AND SURFACES**

Thesis submitted in accordance with the requirement of the
University of Liverpool for the degree of Doctor in Philosophy

by
Farid TARI,

May 1990.

Abstract

This thesis consists of two parts. The first part deals with the orthogonal projections of piecewise smooth surfaces and of triples of surfaces onto planes. We take as a model of piecewise smooth surfaces the variety $X = \{(x, 0, z): x \geq 0\} \cup \{(0, y, z): y \geq 0\}$ and classify germs of maps $R^3, 0 \rightarrow R^2, 0$ up to origin preserving diffeomorphisms in the source which preserve the variety X and any origin preserving diffeomorphisms in the target. This yields an action of a Mather subgroup ${}_X\mathcal{A}$ on $C_3^{\times 2}$, the set of map-germs $R^3, 0 \rightarrow R^2, 0$. We list the orbits of low codimensions of such an action, and give a detailed description of the geometry of each orbit. We extend these results to triples of surfaces.

In the second part of the thesis we analyse the shape of smooth embedded close curves in the plane. A way of piking the local reflexional symmetry of a given curve γ is to consider the centres of bitangent circles to the curve. The set of all these centres is a plane curve called the *Symmetry Set* of γ . We present an equivalent way of tracing the local reflexional symmetry of γ by considering the lines with respect to which a point on γ and its tangent line are reflected to another point on the curve and to its tangent line. The locus of all these lines form the dual curve of the symmetry set of γ . We study the singularities occurring on duals of symmetry sets and their generic transitions in 1-parameter families of curves γ .

A first attempt to define an analogous theory to study the local rotational symmetry in the plane is given. The *Rotational Symmetry Set* of a curve γ is defined to be the locus of centres of rotations taking a point $\gamma(t_1)$ together with its tangent line and its centre of curvature, to $\gamma(t_2)$ together with its tangent line and its centre of curvature. We study the properties of the rotational symmetry set and list the generic transitions of its singularities in 1-parameter families of curves γ .

In the final chapter we investigate the local structure of the midpoint locus of generic smooth surfaces.

Acknowledgements

I am deeply indebted to Peter Giblin for proposing and supervising the work of this thesis. I am also grateful for the hospitality he and his family extended to me during my stay in Liverpool.

I would like to thank Bill Bruce and James Damon for their useful suggestions.

My thanks to the members of the Institute of Mathematics at Warwick University for their hospitality during the several conferences I attended there.

I acknowledge the financial support from the Ministère De L'Enseignement Supérieur D'Algerie and from the Overseas Research Student awards of the CVCP in Great Britain.

My special thanks to Stephanie Daniels for her moral support during the preparation of this thesis.

Introduction

This thesis consists of two parts. The first part deals with the orthogonal projections of piecewise smooth surfaces and of triples of surfaces. For a generic smooth surface, the apparent contour of the surface associated with an orthogonal projection onto a plane is the set of the critical values of the projection. The singularities of apparent contours have been studied by several authors [A3], [B-G2], [Ga], [K], [P1], [P2], [R1]. In the paper “Projections of surfaces with boundary”, J.W.Bruce and P.J.Giblin investigated the singularities of projections of surfaces with boundary [B-G4]. We extend the results in [B-G4] and consider projections of piecewise smooth surfaces in Chapter 1, and of triples of surfaces in Chapter 2. We take as a model of piecewise smooth surfaces the variety $X = \{(x, 0, z): x \geq 0\} \cup \{(0, y, z): y \geq 0\}$ and classify germs of maps $R^3, 0 \rightarrow R^2, 0$ up to origin preserving diffeomorphisms in the source which preserve the variety X and any origin preserving diffeomorphisms in the target, using the results on determinacy of germs in [B-dP-W]. We list the orbits of low codimensions of such an action, and give a detailed description of the geometry of each orbit. It turns out (Theorem 1.4.2 in Chapter 1), that in some cases one can ignore one of the pieces of surface and consider only the projection of the remaining surface with boundary. In Chapter 2, we extend these results to triples of surfaces. The results of the two chapters can also be found in [T].

In second part of the thesis we analyse the shape of smooth embedded close curves in the plane. Given an object in the plane, Brady suggested to fit in discs inside it and consider their centres which he called “Sym-ax” [Bra]. The Sym-ax plays the role of a skeleton in determining the shape of the object. A mathematical definition of the Sym-ax is given in [G-B]. For a smooth embedded curve γ , the closure of the locus of centres of bitangent circles to the curve is called the Symmetry Set of γ . The symmetry set picks the local symmetry structure of the curve γ . Different attempts to study the symmetry set have been made but the most fruitful one is that in [B-G3] which defines it as part of the full bifurcation set of the distance squared function. It is then possible to use results in singularity theory to describe the generic transitions occurring on 1-parameter families of symmetry sets.

An equivalent way of dealing with the local reflexional symmetry in the plane is to consider the lines which reflect a point on the curve and its tangent line to another point on the curve and its tangent line. The set of all these lines is the dual curve of the symmetry set. Two methods of studying the duals of symmetry set of smooth embedded plane curves are given in Chapter 4. The first method, due to J.W.Bruce, expresses the dual of the symmetry set locally as a bifurcation set of a family of maps $R \rightarrow R^2$. The

second method gives it as the discriminant of a map from the plane to the plane or of a symmetric map from the plane to the plane depending on the situation.

In Chapter 5, we give a first attempt of defining an analogous theory to investigate the rotational symmetry in the plane. We consider the centres of rotations taking $\gamma(t_1)$ together with its tangent line and centre of curvature, to $\gamma(t_2)$ together with its tangent line and centre of curvature. The locus of these centres is called the *rotational symmetry set* of the curve γ . Technically, the rotational symmetry set is part of the discriminant of the *centre map*, a map from the plane to the plane. With the help of the criteria of recognition of maps from the plane to the plane in Chapter 3, we study the singularities of the rotational symmetry set and the transitions occurring on generic 1-parameter families of curves γ . An astonishing remark is that the duals of symmetry sets and the rotational symmetry sets have similar behaviour. For instance, the lips in the lips transitions in both sets have four inflexions. The results of Chapter 4 and 5 are also written in [G-T].

A less successful set in shape recognition theory is the midpoint locus. The midpoint locus of a generic smooth curve (or surface) is the locus of centres of midpoints of chords of contact of bitangent circles (or spheres) [G-B]. This set does not appear as a discriminant or a bifurcation set of a map. In [G-B] the midpoint locus of a smooth curve is studied using a direct argument. That argument is hard to extend to the surface case. We present in Chapter 6 a method for dealing with this problem, and study the local structure of the midpoint locus of generic smooth surfaces.

Table of Contents

Chapter 1: Projections of piecewise-smooth surfaces	
1. Introduction	1
2. Classification method.....	4
3. The classification	7
4. The geometry of the projections	18
5. The moduli and the topological versality	37
Chapter 2: Projections of triples of surfaces	
1. Introduction	43
2. Classification method	44
3. The classification	45
4. The geometry of the normal forms in Table 2	49
Chapter 3: Recognition of smooth map germs from the plane to the plane	
1. Introduction	57
2. Recognition of fold and cusp maps	58
3. Recognition of swallowtail maps	62
4. Recognition of lips/beaks maps	66
Chapter 4: Duals of symmetry sets of plane curves	
1. Introduction	68
2. The dual of the symmetry set as a bifurcation set	69
3. The dual of the symmetry set as a discriminant	88
4. Appendix	95
Chapter 5: Rotational symmetry in the plane	
1. Introduction	101
2. The centre map	102
3. The RSS^+	106
4. The RSS^- and the connection with symmetric maps	119
Chapter 6: Midpoint locus of smooth surfaces	
1. Introduction	123
2. Computation of S_f	124
3. The local structure of the midpoint locus of surfaces	129
References	136

Projections of piecewise-smooth surfaces

§1. Introduction

In this chapter we consider singularities of orthogonal projections of piecewise-smooth surfaces on planes. For a generic smooth surface, the apparent contour (outline, profile) of the surface associated with a projection onto a plane is the set of critical values of the projection. The singularities of apparent contours of smooth surfaces have been studied by several authors [A3], [B-G2], [Ga], [K], [P1], [P2], [R1]. J.W.Bruce and P.J.Giblin investigated in [B-G4] the singularities of projections of generic surfaces with boundary. A surface with boundary in R^3 is an embedding of the half plane $\{(x, y), y \geq 0\}$, and an orthogonal projection of the surface is represented by a germ of a map from the plane to the plane in a neighbourhood of the x -axis. A classification of map germs $R^2, 0 \rightarrow R^2, 0$, up to smooth changes of coordinates in the source which preserve the x -axis and any smooth changes of coordinates in the target, is given in that paper.

The geometry of projections of piecewise-smooth surfaces has been considered by J.Callahan in an unpublished note [C]. He described, in the case of two surfaces meeting transversally on a smooth curve (called the “crease”), how the apparent contours of the two surfaces and the projection of the crease change in a neighbourhood of a point on the crease when the piecewise-smooth surface is viewed from any direction. In [R2] J.H.Rieger considered the crease as a space curve and combined the singularities of its projections with those of profiles of surfaces to describe some of the singularities of projections of piecewise-smooth surfaces.

In what follows, we shall take as a local model of piecewise-smooth surfaces the germ at the origin of the set $X = X_1 \cup X_2$ where $X_1 = \{(x, 0, z), x \geq 0\}$ and $X_2 = \{(0, y, z), y \geq 0\}$ (figure 1.1.1). Any piecewise-smooth surface is the image of X by a smooth map-germ which maps X_1 and X_2 diffeomorphically onto their images. The orthogonal projection on a plane of such surface can be represented locally by a germ of a map $f: R^3, 0 \rightarrow R^2, 0$. The map f is a germ of a submersion when the pieces of surface are transverse, and of rank 1 when the surfaces have a common tangent plane at the origin.

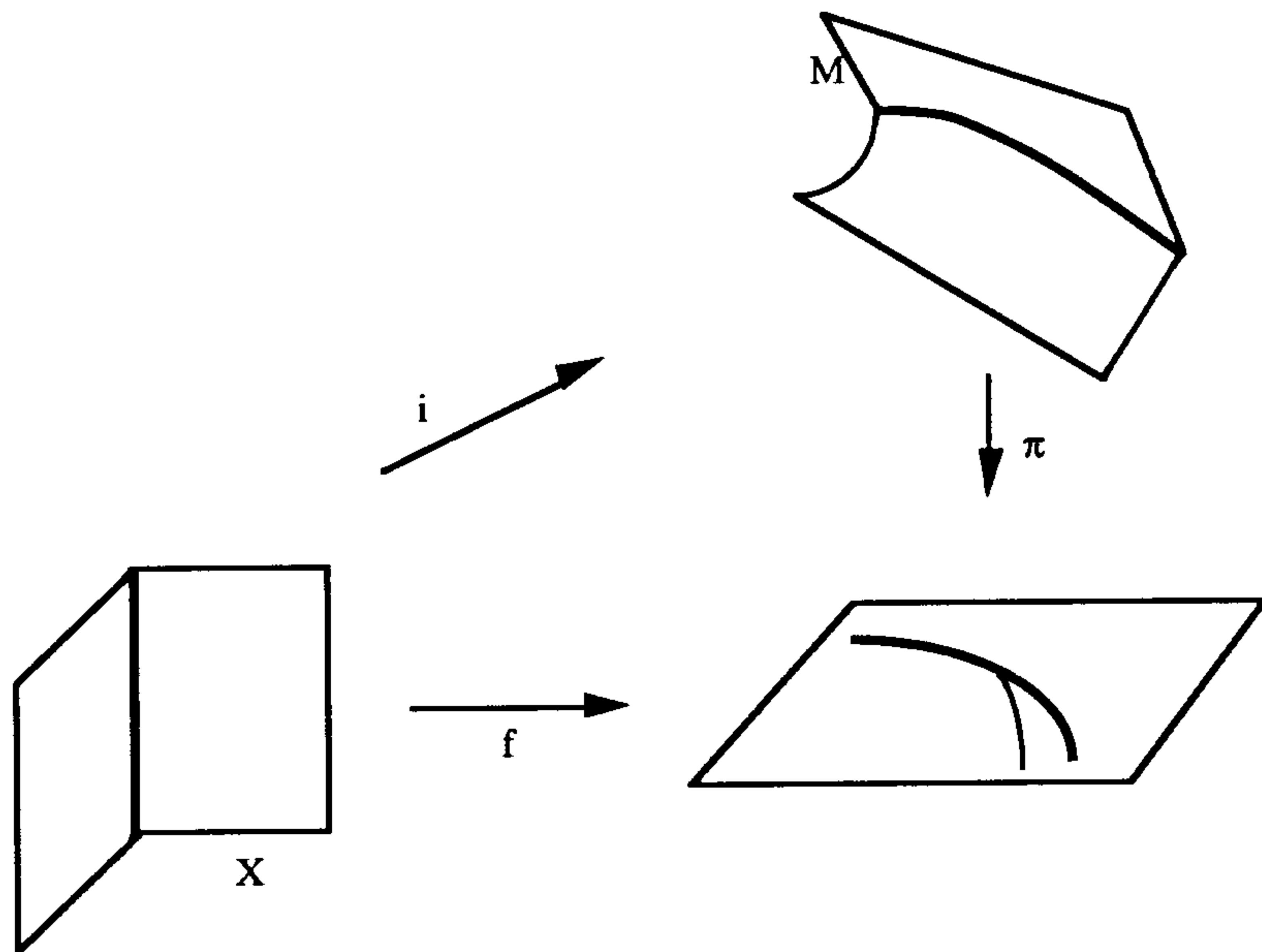

Figure 1.1.1. Projection of a piecewise smooth surface

We classify germs of maps $R^3, 0 \rightarrow R^2, 0$ of rank at least 1 up to smooth origin preserving changes of coordinates in the source which preserve X and smooth origin preserving changes of coordinates in the target. This yields an action of a subgroup ${}_X\mathcal{A}$ of the Mather group \mathcal{A} on $C_3^{\times 2}$. The group ${}_X\mathcal{A}$ preserves the variety X in the source, it is a special geometric subgroup of \mathcal{A} in Damon's terminology [D3]. We give the list of the orbits of germs of rank at least 1 and codimension less than 2 of this action, allowing the codimension to be bigger in the presence of moduli.

1.1.1. Theorem : *The orbits of the action of ${}_X\mathcal{A}$ on $C_3^{\times 2}$ with rank at least 1 and codimension less than 2 are shown in Table 1.*

Table 1 ($\epsilon_i = \pm 1$)

Normal Form	Name	${}_X\mathcal{A}$ -Codimension of the orbit
I. $(\epsilon x + y, z)$	Trivial crease	0
II. $(\epsilon x + y^2 + yz, z)$	Semi-fold	0
III. $(\epsilon x + y^2 + \epsilon_1 y z^k, z)$	III.a $k = 2$ Semi-lips/beaks III.b $k = 3$ Semi-geese	$k - 1$

IV. $(\epsilon x + yz + y^3, z)$	Semi-cusp	1
V. $(\epsilon x + yz + y^4 + \epsilon_1 y^6, z)$	Semi-swallowtail	2
VI. $(\epsilon x + yz^2 + y^2 z + ay^3 + \epsilon_1 y^4, z)$	Lips/beaks on fold lying on crease	3
VII. $(x + \epsilon_1 z^2 + z^{2k+1}, y + \epsilon_2 z^2)$ $k \geq 1$	VII.a $k = 1$ Crease cusp VII.b $k = 2$ Crease rhamphoid cusp	k
VIII. $(x + yz + az^3 + \epsilon_1 z^4 + bz^5, y + \epsilon_2 z^2)$	Double cusp	4
IX. $(ax^2 + by^2 + \epsilon_1 xy + xz + \epsilon_2 yz + cx^2 z + dxyz, z)$	Non-transverse semi-folds	5
X. $(ax^2 + \epsilon_1 y^2 + \epsilon_2 xy + xz + \epsilon_3 yz^2, z)$	Non-transverse semi-lips/beaks	4
XI. $(ax^2 + \epsilon_1 xy + \epsilon_2 yz + xz + \epsilon_3 y^3 + by^4, z)$	Non-transverse semi-cusp	4
XII. $(x + \epsilon_1 y + \epsilon_2 z^2, x^2 + axy + \epsilon_3 z^2 + bx^2 y + cz^3)$	Non-transverse crease cusp	5

The parameters a, b, c, d appearing in the normal forms are moduli. The germs are finitely determined except for some special values of these moduli. These exceptional values are:

Case VI: $a \neq 0$.

Case VIII: $a \neq 0, \epsilon_2, -2\epsilon_2, -\frac{1}{3}\epsilon_2, \frac{2}{3}\epsilon_2, \frac{3}{2}\epsilon_2$.

Case IV: $a \neq 0, b \neq 0, c(2\epsilon_2 b - \epsilon_1) + d(a - b) \neq 0, 4ab - 1 \neq 0$.

Case X: $a \neq 0, \frac{1}{4}\epsilon_1$.

Case XI: $a \neq 0, \epsilon_1 \epsilon_2, \frac{1}{2}\epsilon_1 \epsilon_2$.

Case XII: $a \neq 0, \epsilon_1, b \neq 0, c \neq 0$.

In section 1 we recall the results on determinacy in [B-dP-W], and in section 2 we give the classification which is carried out inductively on the jet level until a sufficient jet is found. In section 3 we interpret geometrically the results of Theorem 1 and apply Damon's results on topological versality to some of the germs with moduli. The results of this chapter are published in [T].

§2. Classification method

Notation : We shall follow the notation in [W3]. We denote by $C_n^{\times p}$ the set of germs at the origin of smooth maps $R^n, 0 \rightarrow R^p$, C_n and C_p the rings of germs of smooth functions at the origin in the source and m_n and m_p their maximal ideals. $J^k(n, p)$ the k -jet denotes the vector space of germs of polynomials, at the origin in the source, of degree $\leq k$, $j^k f$ denotes the Taylor expansion of f of degree k . The group ${}_X\mathcal{A}$ introduced in §1 consists of pairs of germs of origin preserving diffeomorphisms (h, k) in $\text{Diff}(R^3) \times \text{Diff}(R^2)$ with h preserving the piecewise-smooth surface X . We shall denote by ${}_X\mathcal{A}_e$ the pseudo group of pairs of germs of diffeomorphisms at the origin (not necessarily origin preserving) (h, k) with h preserving the piecewise-smooth surface X .

If $(h, k) \in {}_X\mathcal{A}$ we can write $h(x, y, z) = (h_1(x, y, z), h_2(x, y, z), h_3(x, y, z))$ as a representative of h with $h_1(x, 0, z) = h_2(0, y, z) = 0$. Using Hadamard's lemma $h(x, y, z) = (x\tilde{h}_1(x, y, z), y\tilde{h}_2(x, y, z), h_3(x, y, z))$ with $\tilde{h}_1, \tilde{h}_2, h_3$ in C_3 , and $\tilde{h}_1(0, 0, 0) \cdot \tilde{h}_2(0, 0, 0) \cdot h_3(0, 0, 0) \neq 0$ is the condition for h to be the germ of a diffeomorphism at the origin.

The group ${}_X\mathcal{A}$ inherits the action of the group \mathcal{A} on $C_3^{\times 2}$:

$$\begin{aligned} {}_X\mathcal{A} \times C_3^{\times 2} &\longrightarrow C_3^{\times 2} \\ ((h, k), f) &\longmapsto k \circ f \circ h^{-1} \end{aligned}$$

Two germs f, g are equivalent if they lie in the same orbit, that is $g = k \circ f \circ h^{-1}$ for some $(h, k) \in {}_X\mathcal{A}$.

For a given germ f , we need to express the tangent space to the orbit ${}_X\mathcal{A}.f$ of f at f . We recall some notation from [W3]. $V(R^n)$ and $V(R^p)$ denote the C_n and C_p -modules of germs of vector fields on R^n and R^p at the origin, and $m_n.V(R^n)$ and $m_p.V(R^p)$ their maximal ideals. $V(f)$ is the C_n -module of germs of vector field along f , that is germs ξ satisfying $\pi \circ \xi = f$. (See diagram.)

$$\begin{array}{ccc} & & TR^p \\ & \nearrow \xi & \downarrow \pi_p \\ R^n & \xrightarrow{f} & R^p \end{array}$$

One can define homomorphisms of modules as follows:

$$\begin{array}{ccc} tf : V(R^n) & \longrightarrow & V(f) & \quad & wf : V(R^p) & \longrightarrow & V(f) \\ \xi & \longmapsto & Tf \circ \xi & & \eta & \longmapsto & \eta \circ f \end{array}$$

The tangent space to the orbit $\mathcal{A}.f$ of f at f is by definition

$$T\mathcal{A}.f := tf(m_n.V(R^n)) + wf(m_p.V(R^p))$$

We also define the pseudo tangent space

$$T\mathcal{A}_e.f := tf(V(R^n)) + wf(V(R^p))$$

The \mathcal{A} -codimension of f is the codimension of the orbit of f , that is the dimension of the real vector space $V(f)/T\mathcal{A}_e.f$.

In our case ($n = 3, p = 2$) the group acting ${}_X\mathcal{A}$ preserves the piecewise-smooth surface X in the source. We need to replace the set $V(R^3)$ by $V(X)$ the C_n -module of vector fields tangent to X . The tangent space to the ${}_X\mathcal{A}$ -orbit of f at f is then by definition

$$T_X\mathcal{A}.f := tf(V(X) \cap m_3.V(R^3)) + wf(m_2.V(R^2))$$

We also define the pseudo tangent space

$$T_X\mathcal{A}_e.f := tf(V(X)) + wf(V(R^2))$$

The ${}_X\mathcal{A}$ -codimension of f is the dimension of the real vector space $V(f)/T_X\mathcal{A}_e.f$.

The expression for $T_X\mathcal{A}.f$

Let $\xi \in V(X)$. We can write $\xi(x, y, z) = \xi_1(x, y, z)\partial_x + \xi_2(x, y, z)\partial_y + \xi_3(x, y, z)\partial_z$ as a representative of ξ at the origin. Since ξ is tangent to X , $\xi_1(x, 0, z) = \xi_2(0, y, z) = 0$. It follows by Hadamard's lemma that $\xi_1(x, y, z) = x\tilde{\xi}_1(x, y, z)$ and $\xi_2(x, y, z) = y\tilde{\xi}_2(x, y, z)$ for some $\tilde{\xi}_1$ and $\tilde{\xi}_2$ in C_3 . The set $V(X)$ is then the C_3 -module generated by $x\partial_x, y\partial_y, \partial_z$ and $tf(V(X))$ is the C_3 -module generated by $x\frac{\partial f}{\partial x}, y\frac{\partial f}{\partial y}$ and $\frac{\partial f}{\partial z}$. This yields

$$tf(V(X) \cap m_3.V(R^3)) = C_3.\left\{x\frac{\partial f}{\partial x}, y\frac{\partial f}{\partial y}, x\frac{\partial f}{\partial z}, y\frac{\partial f}{\partial z}, z\frac{\partial f}{\partial z}\right\}$$

The set $wf(m_2V(R^2))$ is the pull back by f of the maximal ideal m_2 in C_2 . It is generated by the components of f and is denoted by $f^*m_2\{e_1, e_2\}$, with e_1 and e_2 the standard basis vectors in R^2 . Note that $f^*m_2\{e_1, e_2\}$ is not a C_3 -module. We can now write explicitly the tangent space to the ${}_X\mathcal{A}$ -orbit of f at f :

$$T_X\mathcal{A}.f = C_3.\left\{x\frac{\partial f}{\partial x}, y\frac{\partial f}{\partial y}, x\frac{\partial f}{\partial z}, y\frac{\partial f}{\partial z}, z\frac{\partial f}{\partial z}\right\} + f^*m_2\{e_1, e_2\}$$

and the pseudo tangent space

$$T_X\mathcal{A}_e.f = C_3.\left\{x\frac{\partial f}{\partial x}, y\frac{\partial f}{\partial y}, \frac{\partial f}{\partial z}\right\} + f^*C_2\{e_1, e_2\}$$

We also need the expression for the tangent space to the ${}_X\mathcal{A}_1$ orbit of f , where ${}_X\mathcal{A}_1$ is the subgroup of ${}_X\mathcal{A}$ whose elements have 1-jet the identity.

$$T_X\mathcal{A}_1.f = C_3.\left\{x\frac{\partial f}{\partial x}, y\frac{\partial f}{\partial y}, \frac{\partial f}{\partial z}\right\} \cap m_3^2.C_3^{\times 2} + f^*m_2\{e_1, e_2\}$$

Determinacy and complete transversal

Let \mathcal{G} be any subgroup of a Mather group.

1.2.1. Definition : A map germ $f : R^n, 0 \rightarrow R^p, 0$ is said to be k - \mathcal{G} -determined if any germ g in $C_n^{\times p}$ with the same k -jet of f ($j^k g = j^k f$) is \mathcal{G} -equivalent to f .

The smallest integer k that satisfies this property is called the *degree of \mathcal{G} -determinacy* of f . (If the group \mathcal{G} is clear from the context, it is omitted from the notation.)

Clearly any k -determined germ is equivalent to its k -jet. If f is k -determined, we can consider the induced action of \mathcal{G} on $C_n^{\times p}/m_n^{k+1}.C_n^{\times p} = J^k(n, p)$:

$$J^k \mathcal{G} \times J^k(n, p) \rightarrow J^k(n, p)$$

where $J^k \mathcal{G} = \mathcal{G}/\mathcal{G}_{k+1}$. This is an action of a Lie group on a finite dimensional space. The orbit of $j^k f$ is a smooth submanifold of $J^k(n, p)$. It is possible to describe the behavior of nearby orbits of $j^k f$ (hence those of f).

J.Mather gave a condition for a germ to be finitely determined but his estimation of degree of determinacy is astronomical [Ma]. There are refinements of his results, see [W3] for references. In [B-dP-W] the authors highlighted the role of unipotency and gave a powerful tool to estimate the exact degree of determinacy of map germs. We shall use essentially Theorem 1.9 and Corollary 2.5.2 in [B-dP-W]. Here is an adapted version for the action of ${}_X \mathcal{A}$ on $C_3^{\times 2}$. The statement of the theorem and its proof follow the same lines of Theorem 1.2 in [B-G4].

1.2.2. Theorem : Let $U \subset {}_X \mathcal{A}$ be a subgroup with ${}_X \mathcal{A}_1 \subset U$ and $J^1 U$ unipotent. If a smooth germ $f : R^3, 0 \rightarrow R^2, 0$ satisfies $m_3^{r+1}.C_3^{\times 2} \subset TU.f$, then it is r - ${}_X \mathcal{A}$ -determined.

Proof : Since $m_3^{r+1}.C_3^{\times 2} \subset TU.f \in T_X \mathcal{A}.f$, it follows from [D3] that f is finitely k - ${}_X \mathcal{A}$ -determined for some k . To prove that $j^k f$ (hence f) is r - ${}_X \mathcal{A}$ -determined it is enough to show that any germ g whose r -jet satisfies $j^r g = j^r f$ is in the $J^k U$ -orbit of $j^k f$, that is in the affine space $j^r f + m_3^{r+1}.C_3^{\times 2} \cap J^k(3, 2) \subset J^k U.j^k f$. Since $j^r g = j^r f$ it follows from the approximation lemma [Ma] that $TU.g \subset TU.f + m_3^{r+1}.C_3^{\times 2}$ which yields by hypothesis $TU.g \subset TU.f$ and by passing to the k -jet $T(J^k U).j^k g \subset T(J^k U).j^k f$. This is for every g with $j^r g = j^r f$.

To conclude by applying Corollary 1.5 in [B-dP-W], we need to show that $J^k U$ is a unipotent group. Since $J^1 U$ is unipotent, it is enough to show that U is a closed connected group (Theorem 1.8 [B-dP-W]). This is the case because ${}_X \mathcal{A}_1 \subset U$ and $J_X^1 \mathcal{A}$ is closed. \square

1.2.3. Corollary : *If $f : R^3, 0 \rightarrow R^2, 0$ satisfies*

$$m_3^l.C_3^{\times 2} \subset C_3.\left\{x\frac{\partial f}{\partial x}, y\frac{\partial f}{\partial y}, \frac{\partial f}{\partial z}\right\} + f^*m_2.C_2^{\times 2} + m_3^{l+1}.C_3^{\times 2} \quad \text{and}$$

$$m_3^{k+1}.C_3^{\times 2} \subset T_X\mathcal{A}_1.f + m_3^{k+l+1}.C_2^{\times 2}$$

then f is $k - {}_X\mathcal{A}_1$ -determined.

Proof : The set $m_3^l.C_3^{\times 2}$ is a C_3 -module, hence by Nakayama Lemma applied to the first inclusion $m_3^l.C_3^{\times 2} \subset C_3.\left\{x\frac{\partial f}{\partial x}, y\frac{\partial f}{\partial y}, \frac{\partial f}{\partial z}\right\} + f^*m_2.C_2^{\times 2}$. Substituting this inclusion in the second one in the corollary we get

$$m_3^{k+1}.C_3^{\times 2} \subset T_X\mathcal{A}_1.f + m_3^{k+1}\left(C_3\left\{x\frac{\partial f}{\partial x}, y\frac{\partial f}{\partial y}, \frac{\partial f}{\partial z}\right\} + f^*m_2.C_2^{\times 2}\right)$$

$$\subset T_X\mathcal{A}_1.f + m_3^{k+1}\left(f^*m_2.C_2^{\times 2} + m_2^{k+1}\right).C_2^{\times 2}$$

This is because $m_3^{k+1}.C_3\left\{x\frac{\partial f}{\partial x}, y\frac{\partial f}{\partial y}, \frac{\partial f}{\partial z}\right\} \subset T_X\mathcal{A}_1.f$. It follows by Lemma 2.6 in [B-dP-W] that $m_3^{k+1}.C_3^{\times 2} \subset T_X\mathcal{A}_1.f$. Using Theorem 2.5.2 for $U = {}_X\mathcal{A}_1$ we conclude that f is $k - {}_X\mathcal{A}_1$ -determined. \square

1.2.4. Remark : We can replace ${}_X\mathcal{A}_1$ in Corollary 1.2.3 by a subgroup $U \subset {}_X\mathcal{A}$ satisfying ${}_X\mathcal{A}_1 \subset U$ and J^1U unipotent.

A useful tool to simplify calculations in finding the orbits in the space of $k + 1$ -jets whose k -jet is f is the following proposition ([B-dP]. See also Proposition 1.4 [B-G4]).

1.2.5. Proposition : *Let f be a k -jet in $J^k(3, 2)$ and let T be a vector subspace of the space of germs of homogeneous mapping $R^3, 0 \rightarrow R^2, 0$ of degree $k + 1$, $H^{k+1}(3, 2)$, with $J^{k+1}(T_X\mathcal{A}_1.f) \cap H^{k+1}(3, 2) + T = H^{k+1}(3, 2)$. Then any $k + 1$ jet g with k -jet f is ${}_X\mathcal{A}_1$ -equivalent to $f + t$ for some t in T .*

T is called the *complete $(k + 1)$ -transversal*.

§3. The classification

The classification is carried out inductively on the jet level. A sufficient jet is given its corresponding number in Table 1. We denote by \simeq the ${}_X\mathcal{A}$ -equivalence relation on $J^k(3, 2)$, (x, y, z) and (u, v) the coordinates in the source and target, and by ϵ_i the sign \pm . Some germs are considered to be equivalent by interchanging the two surfaces X_1 and X_2 .

The 1-jets.

If f has rank 2, then

if the restriction of f to the crease is an immersion, then using a later result (1.4.1) we have

$$j^1 f \simeq (ax + by, z) \simeq \begin{cases} (\epsilon x + y, z) & \text{Case I, or} \\ (x, z) \end{cases}$$

if not $j^1 f \simeq (x, y)$.

If f has rank 1, then $j^1 f \simeq \begin{cases} (0, z) \\ (x + \epsilon y, 0) \\ (x, 0) \end{cases}$, or

If f has rank 0, $j^1 f = (0, 0)$.

The 1-jets $(x, 0)$ and $(0, 0)$ lead to germs of higher codimensions.

1.3.1. Proposition : *The germ $(\epsilon x + y, z)$ is stable.*

Proof: It is easy to check that $(x + \epsilon y, z)$ is $1-X$ \mathcal{A} -determined using Corollary 1.2.3. In this case $l = k = 1$, and $T_X \mathcal{A}_e.f = V(f)$. \square

The 1-jet $f = (\epsilon x, z)$

One can easily show that $T(J_X^2 \mathcal{A}_1).f + R\{(y^2, 0), (yz, 0)\} = H^2(3, 2)$. It follows from Proposition 1.2.5 that any 2-jet g with $j^1 g = (\epsilon x, z)$ is equivalent to $(\epsilon x + ay^2 + byz, z)$ for some a and b in R .

One can show by considering explicit changes of coordinates in the source and target, that the orbits in $J^2(3, 2)$ with 1-jet $(\epsilon x, z)$ are :

$(\epsilon x + y^2 + yz, z)$	if $a \neq 0, b \neq 0$	See 1.3.2
$(\epsilon x + y^2, z)$	if $a \neq 0, b = 0$	See 1.3.3
$(\epsilon x + yz, z)$	if $a = 0, b \neq 0$	See 1.3.4
$(\epsilon x, z)$	if $a = b = 0$	See 1.3.5

1.3.2. Proposition : *The germ $f = (\epsilon x + y^2 + yz, z)$ is stable.*

Proof: f is $2-X$ \mathcal{A} -determined by Corollary 1.2.3. Indeed,

$$m_3^2.C_3^{\times 2} \subset C_3.\left\{x\frac{\partial f}{\partial x}, y\frac{\partial f}{\partial y}, \frac{\partial f}{\partial y}\right\} + f^*m_2.C_2^{\times 2} + m_3^3.C_3^{\times 2} \quad \text{and}$$

$$m_3^3.C_3^{\times 2} \subset T_X \mathcal{A}_1.f + m_3^5.C_3^{\times 2}$$

It is easy to check that $T_X \mathcal{A}_e.f = V(f)$. Therefore f is stable. \square

1.3.3. Proposition : (i) Any $k + 1$ -jet with k -jet $(\epsilon x + y^2, z)$ and $k \geq 2$ is $X\mathcal{A}$ -equivalent to $(\epsilon x + y^2 + \epsilon_1 y z^k, z)$ or $(\epsilon x + y^2, z)$. ($\epsilon_1 = (\pm 1)^{k+1}$.)

(ii) The jet $(\epsilon x + y^2 + \epsilon_1 y z^k, z)$ is $k + 1$ -determined and has codimension $k - 1$. This is the case III on Table 1.

Proof: (i) Let f denote the k -jet $(\epsilon x + y^2, z)$. We can see that

$$T(J_X^{k+1} \mathcal{A}_1).f + R.\{(yz^k, 0)\} = H^{k+1}(3, 2)$$

It follows from Proposition 1.2.5 that any $(k + 1)$ -jet with k -jet f is equivalent to $(\epsilon x + y^2 + a y z^k, z)$. Now linear changes of coordinates $(x, y, z) \mapsto (x, y, ((\text{sign}(a))^{k+1}.a)^{\frac{1}{k}} z)$ in the source and $(u, v) \mapsto (u, ((\text{sign}(a))^{k+1}.a)^k v)$ in the target give the orbits in $J^{k+1}(3, 2)$ with k -jet f :

$$\begin{aligned} (\epsilon x + y^2 + \epsilon_1 y z^k, z) & \text{ if } a \neq 0 \\ (\epsilon x + y^2, z) & \text{ if } a = 0 \end{aligned}$$

(ii) let f denote the $k + 1$ -jet $(\epsilon x + y^2 + \epsilon_1 y z^k, z)$. We have:

$$x \frac{\partial f}{\partial x} = (\epsilon x, 0)$$

$$y \frac{\partial f}{\partial y} = (y^2 + \epsilon_1 y z^k, 0)$$

$$\frac{\partial f}{\partial z} = (\epsilon_1 k y z^{k-1}, 1)$$

It is easy to check that $m_3^2.C_3^{\times 2} \subset C_3\{x \frac{\partial f}{\partial x}, y \frac{\partial f}{\partial y}, \frac{\partial f}{\partial z}\} + f^*m_2.C_2^{\times 2} + m_3^3.C_3^{\times 2}$. To prove that f is $k + 1$ -determined using Corollary 1.2.3, we need to show that $m_3^{k+2}.C_3^{\times 2} \subset T_X \mathcal{A}_1.f + m_3^{k+4}.C_3^{\times 2}$. For, it is enough to show that all monomials in $C_3^{\times 2}$ of degree $k + 3$ and $k + 2$ are in $T_X \mathcal{A}_1.f$ modulo $m_3^{k+4}.C_3^{\times 2}$.

Degree $k + 3$: Using $x \frac{\partial f}{\partial x}, y \frac{\partial f}{\partial y}$, we can trivially show that all monomials of degree $k + 3$ in $H^{k+3}(3, 2)$, except $(yz^{k+2}, 0)$, are in $T_X \mathcal{A}_1.f + m_3^{k+4}.C_3^{\times 2}$. To get $(yz^{k+2}, 0)$, we use $z^3 \frac{\partial f}{\partial z} - (0, f_2^3) = (\epsilon_1 k y z^{k+2}, 0)$.

Degree $k + 2$: Now we can work modulo $m_3^{k+3}.C_3^{\times 2}$. As for degree $k + 3$ all monomials of degree $k + 2$, except $(yz^{k+1}, 0)$, are trivially in $T_X \mathcal{A}_1.f + m_3^{k+3}.C_3^{\times 2}$. To get $(yz^{k+1}, 0)$, we use $z^2 \frac{\partial f}{\partial z} - (0, f_2^2) = (\epsilon_1 k y z^{k+1}, 0)$.

By Corollary 1.2.3, f is $(k + 1) -_X \mathcal{A}$ -determined. It is not hard to show that $T_X \mathcal{A}_e.f \oplus R.\{(y, 0), (yz, 0), \dots, (yz^{k-2}, 0)\} = V(f)$, where \oplus denotes the direct sum. Hence f is of codimension $k - 1$. \square

1.3.4. Proposition : 1.(i) The orbits in $J^3(3,2)$ with 2-jet $(\epsilon x + yz, z)$ are $(\epsilon x + yz + y^3, z)$ and $(\epsilon x + yz, z)$.

(ii) The jet $(\epsilon x + yz + y^3, z)$ is 3- $X\mathcal{A}$ -determined and of codimension 1. It is the case IV in Table 1.

2. The 6-jet $(\epsilon x + yz + y^4 + \epsilon_1 y^6, z)$ is 6- $X\mathcal{A}$ -determined and of codimension 2. It is the case V in Table 1.

Proof : (1). The proof follows the same line that of Proposition 1.3.3. For 1(i), we show that the complete 3-transversal is $R.\{(y^3, 0)\}$. The result follows by considering linear changes of coordinates in the source and target.

For (ii) we apply Remark 1.2.4. Here $l = k = 3$ and $m_3^4.C_3^{\times 2} \subset T_X\mathcal{A}_1.f + R.\{(0, f_1)\} + m_7^4.C_3^{\times 2}$.

It is easy to check that $T_X\mathcal{A}_e.f \oplus R.\{(0, y)\} = V(f)$, therefore f is of codimension 1.

(2). We consider the 3-jet $(\epsilon x + yz, z)$. We find that the orbits in 4-Jet with 3-jet $(\epsilon x + yz, z)$ are $(\epsilon x + yz + y^4, z)$ and $(\epsilon x + yz, z)$. There is one orbit in the 5-Jet with 4-jet $(\epsilon x + yz + y^4, z)$, it is $(\epsilon x + yz + y^4, z)$ itself. Now in the 6-Jet there are 2 orbits with 5-jet $(\epsilon x + yz + y^4, z)$: $(\epsilon x + yz + y^4 + \epsilon_1 y^6, z)$ and $(\epsilon x + yz + y^4, z)$. Applying Corollary 1.2.3 to the germ $f = (\epsilon x + yz + y^4 + \epsilon_1 y^6, z)$ with $l = 4$ and $k = 6$ we find that it is 6- $X\mathcal{A}$ -determined. It is not hard to see that $T_X\mathcal{A}_e.f \oplus R.\{(0, y^2), (0, y^3)\} = V(f)$. Therefore, f is of codimension 2. \square

Note that the 4-jet $(\epsilon x + yz, z)$ and the 6-jet $(\epsilon x + yz + y^4, z)$ yield germs of higher codimension.

1.3.5. Proposition : (i) Any 3-jet with 2-jet $(\epsilon x, z)$ is $X\mathcal{A}$ equivalent to one of the following: $(\epsilon x + yz^2 + y^2z + ay^3, z), a \in R, (\epsilon x + \epsilon_1 yz^2 + y^3, z), (\epsilon x + y^2z + y^3, z), (x + y^2z, z), (\epsilon x + yz^2, z), (\epsilon x + y^3, z), (\epsilon x, z)$.

(ii) Any 4-jet with 3-jet $(\epsilon x + yz^2 + y^2z + ay^3, z)$ is equivalent to $(\epsilon x + yz^2 + y^2z + ay^3 + \epsilon_1 y^4, z)$ or $(\epsilon x + yz^2 + y^2z + ay^3, z)$ provided $a \neq 1$.

(iii) The germ $(\epsilon x + yz^2 + y^2z + ay^3 + \epsilon_1 y^4, z)$ is 4- $X\mathcal{A}$ -determined when $a \neq 0$. This is the case VI in Table 1. The germ $(\epsilon x + yz^2 + y^2z + ay^3, z)$ is 4- $X\mathcal{A}$ -determined provided $a \neq 0, \frac{1}{4}, \frac{1}{3}$.

Proof : (i). It is easy to check that if $f = (\epsilon x, z)$, then

$$T(J_X^3\mathcal{A}_1).f + R.\{(yz^2, 0), (y^2z, 0), (y^3, 0)\} = H^3(3, 2)$$

By Proposition 1.2.5, any 3-jet with 2-jet $(\epsilon x, z)$ is equivalent to $(\epsilon x + ay^3 + byz^2 + cy^2z, z)$ for some $a, b, c \in R$. The statement follows by considering changes of

coordinates in the source and target for the following cases: $a \neq 0, b \neq 0, c \neq 0$; $a = 0, b \neq 0, c \neq 0$; $a \neq 0, b \neq 0, c = 0$; $a \neq 0, b = 0, c \neq 0$; $a = b = 0, c \neq 0$; $a = c = 0, b \neq 0$; $a \neq 0, b = c = 0$; $a = b = c = 0$.

The germ $(\epsilon x + yz^2 + y^2z + ay^3, z)$ is a continuous 1-parameter family of non- X - \mathcal{A} -equivalent germs. In Arnol'd terminology it is a non-simple germ. The parameter a is called a “*modulus*”.

The germs in Proposition 1.3.5 (i), except the first one, lead to germs of higher codimension. We shall not deal with them.

(ii) and (iii). Let f denote the 3-jet $(\epsilon x + yz^2 + y^2z + ay^3, z)$. Then

$$x \frac{\partial f}{\partial x} = (\epsilon x, 0)$$

$$y \frac{\partial f}{\partial y} = (yz^2 + 2y^2z + 3ay^3, 0)$$

$$\frac{\partial f}{\partial z} = (2yz + y^2, 1)$$

We need to compute the complete 4-transversal of f . All the homogeneous monomials of the form $(xP, 0), (z^4, 0), (0, P)$ are in $T(J_X^4 \mathcal{A}_1).f$. We have only to consider those of the form $(y^i z^{4-i}, 0)$. If we assume that $(y^4, 0)$ is in the complete 4-transversal, we show using the vectors $z^2 \frac{\partial f}{\partial z}, yz \frac{\partial f}{\partial y}, y^2 \frac{\partial f}{\partial y} - (3ay^4, 0)$, that provided $a \neq 1$, all the monomials $(y^i z^{4-i}, 0)$ are in $T(J_X^4 \mathcal{A}_1).f + R.\{(y^4, 0)\} = H^4(3, 2)$. By Proposition 1.2.5, any 4-jet with 3-jet as f is equivalent to $(\epsilon x + yz^2 + y^2z + ay^3 + by^4, z)$ for some $b \in R$, provided $a \neq 1$. Linear changes of coordinates in the source and target yield the following orbits in the 4-Jet with 3-jet as f :

$$(\epsilon x + yz^2 + y^2z + ay^3 + \epsilon_1 y^4, z) \quad \text{if } b \neq 0, (\epsilon_1 = \pm 1)$$

$$(\epsilon x + yz^2 + y^2z + ay^3, z) \quad \text{if } b = 0$$

The claim now is, provided $a \neq 0$, the germ $(\epsilon x + yz^2 + y^2z + ay^3 + \epsilon_1 y^4, z)$ is 4- X - \mathcal{A} -determined, and provided $a \neq 0, \frac{1}{4}, \frac{1}{3}$ the germ $(\epsilon x + yz^2 + y^2z + ay^3, z)$ is 4- X - \mathcal{A} -determined.

let $f = (\epsilon x + yz^2 + y^2z + ay^3 + \epsilon_1 y^4, z)$. Then,

$$x \frac{\partial f}{\partial x} = (\epsilon x, 0)$$

$$y \frac{\partial f}{\partial y} = (yz^2 + 2y^2z + 3ay^3 + 4\epsilon_1 y^4, 0)$$

$$\frac{\partial f}{\partial z} = (2yz + y^2, 1)$$

It is not hard to see that $m_3^3.C_3^{\times 2} \subset C_3.\{x \frac{\partial f}{\partial x}, y \frac{\partial f}{\partial y}, \frac{\partial f}{\partial z}\} + f^*m_2.C_2^{\times 2} + m_3^4.C_3^{\times 2}$ for $a \neq 0$. We need to show that $m_3^5.C_3^{\times 2} \subset T_X \mathcal{A}_1.f + m_3^8.C_3^{\times 2}$, that is all monomials of degree 7, 6 and 5 are in $T_X \mathcal{A}_1.f$ modulo $m_3^8.C_3^{\times 2}$.

For monomials of degree 7, any one which is of the form $(xP, 0), (z^7, 0), (0, P)$ is trivially in $T_X \mathcal{A}_1.f + m_3^8.C_3^{\times 2}$. One notices that $3(f_1.f_2^3, 0) - z^3 y \frac{\partial f}{\partial y} - z^4 \frac{\partial f}{\partial z} \equiv -(3\epsilon_1 y^4 z^3, 0)$. Hence $(y^4 z^3, 0) \in T_X \mathcal{A}_1.f + m_3^8.C_3^{\times 2}$.

The vectors $yz^4 \frac{\partial f}{\partial y}, y^2 z^3 \frac{\partial f}{\partial y}, z^5 \frac{\partial f}{\partial z}$ are generated by the monomials $\{(y^3 z^4, 0), (y^2 z^5, 0), (yz^6, 0)\}$. The determinant of the matrix of their coordinates with respect to this basis is $3(a-1)$. Hence for $a \neq 1, (y^3 z^4, 0), (y^2 z^5, 0), (yz^6, 0) \in T_X \mathcal{A}_1.f + m_3^8.C_3^{\times 2}$.

Now provided $a \neq 0$ we can get the monomials $(y^5 z^2, 0), (y^6 z, 0)$ and $(y^7, 0)$ from $y \frac{\partial f}{\partial y}$. Therefore all monomials of degree 7 are in $T_X \mathcal{A}_1.f + m_3^8.C_3^{\times 2}$.

We can prove, following the same method, that provided $a \neq 0, 1$, all monomials of degree 6 and 5 are in $T_X \mathcal{A}_1.f + m_3^8.C_3^{\times 2}$.

Now we are going to use vectors which depend only on the 3-jet of f .

$$(1). \left(f_1 \frac{\partial f}{\partial z} - (0, f_1) \right) = (ay^5 + (2a+1)y^4 z + 3y^3 z^2 + 2y^2 z^3, 0)$$

$$(2). y^3 \frac{\partial f}{\partial y} = (3ay^5 + 2y^4 z + y^3 z^2, 0)$$

$$(3). y^2 z \frac{\partial f}{\partial y} = (3ay^4 z + 2y^3 z^2 + y^2 z^3, 0)$$

$$(4). yz^2 \frac{\partial f}{\partial y} = (3ay^3 z^2 + 2y^2 z^3 + yz^4, 0)$$

$$(5). yz^2 \frac{\partial f}{\partial y} \equiv (2yz^4 + y^2 z^3, 0)$$

The determinant of the matrix of the coordinates of these vectors in the basis $\{(y^5, 0), (y^4 z, 0), (y^3 z^2, 0), (y^2 z^3, 0), (yz^4, 0)\}$ is non-zero if and only if $a \neq 0, \frac{1}{4}, \frac{1}{3}$. Multiplying the above vectors by z^2 we obtain all monomials of degree 7 modulo $m_3^8.C_3^{\times 2}$, and multiplying them by z we get all monomials of degree 6 modulo $m_3^8.C_3^{\times 2}$. Therefore

$$m_3^5.C_3^{\times 2} \subset T_X \mathcal{A}_1.f + R.\{(0, f_1)\} + m_3^8.C_3^{\times 2}$$

provided $a \neq 0, \frac{1}{4}, \frac{1}{3}$. The vectors used here depend only on the 3-jet of f . Thus $(\epsilon x + yz^2 + y^2 z + ay^3, z)$ is 4- $X\mathcal{A}$ -determined provided $a \neq 0, \frac{1}{4}, \frac{1}{3}$.

Combining the two methods we conclude that $f = (\epsilon x + yz^2 + y^2 z + ay^3 + \epsilon_1 y^4, z)$ is 4- $X\mathcal{A}$ -determined provided $a \neq 0$. The value $a = 1$ is exceptional for the calculation in the complete 4-transversal. When $a = 1$ another normal form is needed.

It is not difficult to show that $T_X \mathcal{A}_e.f \oplus R.\{(y, 0), (y^2, 0), (y^3, 0)\} = V(f)$. Hence codimension of f is 3. (The 3-jet of f is of codimension 4.) \square

The 1-jet (x, y)

The complete 2-transversal of (x, y) is $R.\{(yz, 0), (z^2, 0), (0, xz), (0, z^2)\}$. Any 2-jet with 1-jet as f is equivalent to $(x + ayz + bz^2, cxz + dz^2 + y)$ for some a, b, c, d in R . Using Mather's lemma in $J^2(3, 2)$ for the curve $V = \{(x + ayz + bz^2, y + cxz + dz^2), c \in R\}$, we deduce that if $b \neq 0$, $(x + ayz + bz^2, cxz + dz^2 + y) \simeq (x + ayz + bz^2, y + dz^2)$. We can show similarly that if $d \neq 0$, $(x + ayz + bz^2, y + dz^2) \simeq (x + bz^2, y + dz^2)$. For our investigation, the relevant orbits in $J^2(3, 2)$ with 1-jet (x, y) are:

$$(x + \epsilon_1 z^2, y + \epsilon_2 z^2) \quad \text{See 1.3.6}$$

$$(x + yz, y + \epsilon_2 z^2) \quad \text{See 1.3.7}$$

1.3.6. Proposition : (i) *The orbits in the p -Jet whose $(p-1)$ -jet $(x + \epsilon_1 z^2, y + \epsilon_2 z^2)$ are $(x + \epsilon_1 z^2, y + \epsilon_2 z^2)$ if $p = 2k$, and $(x + \epsilon_1 z^2 + z^{2k+1}, y + \epsilon_2 z^2)$ and $(x + \epsilon_1 z^2, y + \epsilon_2 z^2)$ if $p = 2k + 1$.*

(ii) *The germ $(x + \epsilon_1 z^2 + z^{2k+1}, y + \epsilon_2 z^2)$ is $(2k + 1) -_X \mathcal{A}$ -determined. Its codimension is k . It is the case VII in Table 1.*

Proof : (i) follows by considering the p -complete transversal of $(x + \epsilon_1 z^2, y + \epsilon_2 z^2)$.

(ii). If we write $f = (x + \epsilon_1 z^2 + z^{2k+1}, y + \epsilon_2 z^2)$ then

$$x \frac{\partial f}{\partial x} = (x, 0)$$

$$y \frac{\partial f}{\partial y} = (0, y)$$

$$\frac{\partial f}{\partial z} = (2\epsilon_1 z + (2k + 1)z^{2k}, 2\epsilon_2 z)$$

We can easily show that $m_3^2.C_3^{\times 2} \subset C_3.\{x \frac{\partial f}{\partial x}, y \frac{\partial f}{\partial y}, \frac{\partial f}{\partial z}\} + f^*.m_2.C_2^{\times 2} + m_3^3.C_3^{\times 2}$ and $m_3^{2k+2}.C_3^{\times 2} \subset T_X \mathcal{A}_1.f + m_3^{2k+4}.C_3^{\times 2}$, and conclude that f is $(2k + 1) -_X \mathcal{A}$ -determined. It is also not hard to show that $T_X \mathcal{A}_e.f \oplus R.\{(z, 0), (z^3, 0), \dots, (z^{2k-1}, 0)\} = V(f)$, so that codimension of f is k . \square

The 2-jet $(x + yz, y + \epsilon_2 z^2)$

The calculations in this case are complicated to handle. We shall state the results omitting the calculations (but the method is identical to that used above). A jet in $J^3(3, 2)$ with 2-jet as $(x + yz, y + \epsilon_1 z^2)$ is equivalent $(x + yz + az^3, y + \epsilon_2 z^2)$ for some a in R . The germ $(x + yz + az^3, y + \epsilon_1 z^2)$ is a family of non-equivalent germs, a is a parameter modulus. Its complete 4-transversal is $R.\{(z^4, 0)\}$ if $a \neq \frac{3}{2}\epsilon_2$. The orbits in the 4-Jet with 3-jet $(x + yz + az^3, y + \epsilon_2 z^2)$ are, for $a \neq \frac{3}{2}\epsilon_2$, $(x + yz + az^3 + \epsilon_1 z^4, y + \epsilon_2 z^2)$ and $(x + yz + az^3, y + \epsilon_2 z^2)$.

Now, the 5-complete transversal of $(x + yz + az^3 + \epsilon_1 z^4, y + \epsilon_1 z^2)$ is $R.\{(z^5, 0)\}$. Any 5-jet with 4-jet $(x + yz + az^3 + \epsilon_1 z^4, y + \epsilon_2 z^2)$ is equivalent to $(x + yz + az^3 + \epsilon_1 z^4 + bz^5, y + \epsilon_2 z^2)$ for some b . (b is also a modulus.)

1.3.7. Proposition : *The germ $(x + yz + az^3 + \epsilon_1 z^4 + bz^5, y + \epsilon_2 z^2)$ is 5- $X\mathcal{A}$ -determined if $a \neq 0, \epsilon_2, -2\epsilon_2, -\frac{1}{3}\epsilon_2, \frac{2}{3}\epsilon_2, \frac{3}{2}\epsilon_2$. The (orbit) codimension of f when 5-determined is 4. This is the case XIII in Table 1.*

1.3.8. Remark : When f is 5-determined

$$T_X \mathcal{A}_e.f \oplus R.\{(z, 0), (0, z), (z^3, 0), (z^5, 0)\} = V(f)$$

The 1-jet $(0, z)$

The complete 2-transversal is $R.\{(x^2, 0), (y^2, 0), (xy, 0), (xz, 0), (yz, 0)\}$. Any 2-jet with 1-jet $(0, z)$ is equivalent to $(ax^2 + by^2 + cxy + dxz + eyz, z)$ for some a, b, c, d, e in R . By explicit changes of coordinates in the source and target, one can compute the orbits in the 2-jet whose 1-jet $(0, z)$. The relevant ones in our investigation are :

$(ax^2 + by^2 + \epsilon_1 xy + xz + \epsilon_2 yz, z)$	if $a, b, c, d, e \neq 0$	See 1.3.9
$(ax^2 + \epsilon_1 y^2 + \epsilon_2 xy + xz, z)$	if $a, b, c, d \neq 0, e = 0$	See 1.3.10
$(ax^2 + \epsilon_1 xy + xz + \epsilon_2 yz, z)$	if $a, c, d \neq 0, b = 0$	See 1.3.11

1.3.9. Proposition : (i). *Any 3-jet with 2-jet $(ax^2 + by^2 + \epsilon_1 xy + xz + \epsilon_2 yz, z)$ is equivalent to $(ax^2 + by^2 + \epsilon_1 xy + xz + \epsilon_2 yz + cx^2 z + dxyz, z)$ for some c and d in R .*

(ii). *The 3-jet $(ax^2 + by^2 + \epsilon_1 xy + xz + \epsilon_2 yz + cx^2 z + dxyz, z)$ is 3- $X\mathcal{A}$ -determined if $a \neq 0, b \neq 0, c(2\epsilon_2 b - \epsilon_1) + d(a - b) \neq 0, 4ab - 1 \neq 0$. It is the case IX in Table 1. Its codimension is 5, a, b, c, d are moduli.*

Proof : (i). The complete 3-transversal is $R.\{(xyz, 0), (x^2 z, 0)\}$, so that any 3-jet with 2-jet $(ax^2 + by^2 + \epsilon_1 xy + xz + \epsilon_2 yz, z)$ is equivalent to $(ax^2 + by^2 + \epsilon_1 xy + xz + \epsilon_2 yz + cx^2 z + dxyz, z)$.

(ii). Let $f = (ax^2 + by^2 + \epsilon_1 xy + xz + \epsilon_2 yz + cx^2 z + dxyz, z)$. Then

$$x \frac{\partial f}{\partial x} = (2ax^2 + \epsilon_1 xy + xz + 2cx^2 z + dxyz, 0)$$

$$y \frac{\partial f}{\partial y} = (2by^2 + \epsilon_1 xy + \epsilon_2 yz + dxyz, 0)$$

$$\frac{\partial f}{\partial z} = (x + \epsilon_2 y + cx^2 + dxy, 1)$$

One can easily show that $l = 3$ in Corollary 1.2.3 provided $a \neq 0, b \neq 0, 4ab - 1 \neq 0$. We want to prove that $m_3^4.C_3^{\times 2} \subset T_X \mathcal{A}_1.f + m_3^7.C_3^{\times 2}$. We start by showing that all monomials of degree 6 are in $T_X \mathcal{A}_1.f$ modulo $m_3^7.C_3^{\times 2}$. Using $\frac{\partial f}{\partial z}$ one can see that all monomials of degree 6 of the form $(0, P)$ are in $T_X \mathcal{A}_1.f$ modulo $m_3^7.C_3^{\times 2}$. The next step is to get all monomials of degree 6 of the form $(zP, 0)$. We notice that $2(f_1.f_2^4, 0) - z^4 x \frac{\partial f}{\partial x} - z^4 y \frac{\partial f}{\partial y} - z^5 \frac{\partial f}{\partial z} = -(cx^2 z^4 + dxyz^4, 0)$. We have $f_1 f_2^3 \cdot \frac{\partial f}{\partial z} - (0, f_1 f_2^3) \equiv (ax^3 z^3 + b\epsilon_2 y^3 z^3 + (a\epsilon_2 + \epsilon_1)x^2 y z^3 + (b + \epsilon_1 \epsilon_2)xy^2 + x^2 z^4 + y^2 z^4, 0)$. A suitable combination of this vector with $z^3 x^2 \frac{\partial f}{\partial x}, z^3 y^2 \frac{\partial f}{\partial y}, z^3 yx \frac{\partial f}{\partial x}, z^3 xy \frac{\partial f}{\partial y}$ yield $(x^2 z^4 + y^2 z^4 + 2\epsilon_2 xyz^4, 0)$. We also have $(f_1 f_2^4, 0) \equiv (ax^2 z^4 + by^2 z^4 + \epsilon_1 xyz^4, 0)$. Therefore $(x^2 z^4, 0), (y^2 z^4, 0)$ and $(xyz^4, 0)$ are in $T_X \mathcal{A}_1.f$ modulo $m_3^7.C_3^{\times 2}$ provided $c(2\epsilon_2 b - \epsilon_1) + d(a - b) \neq 0$.

Now it is a matter of using combinations of the vectors $x \frac{\partial f}{\partial x}$ and $y \frac{\partial f}{\partial y}$ to get all monomials of degree 6. The exceptional values for a and b are $a = 0, b = 0, 4ab - 1 = 0$.

The calculations for degree 5 and 4 follow the same steps of those of degree 6. We conclude that f is 3- $X\mathcal{A}$ -determined provided $a \neq 0, b \neq 0, c(2\epsilon_2 b - \epsilon_1) + d(a - b) \neq 0, 4ab - 1 \neq 0$.

One can show that

$$T_X \mathcal{A}.f \oplus R.\{(y, 0), (x^2, 0), (y^2, 0), (x^2 z, 0), (xyz, 0)\} = V(f)$$

The codimension of f is then 5. □

1.3.10. Proposition : (i) *The orbits in the 3-Jet with 2-jet as $(ax^2 + \epsilon_1 y^2 + \epsilon_2 xy + xz, z)$ are $(ax^2 + \epsilon_1 y^2 + \epsilon_2 xy + xz + \epsilon_3 yz^2, z)$, $(ax^2 + \epsilon_1 y^2 + \epsilon_2 xy + xz + \epsilon_3 xyz, z)$ and $(ax^2 + \epsilon_1 y^2 + \epsilon_2 xy + xz, z)$.*

(ii). *The germ $(ax^2 + \epsilon_1 y^2 + \epsilon_2 xy + xz + \epsilon_3 yz^2, z)$ is 3- $X\mathcal{A}$ -determined if and only if $a \neq 0, \frac{\epsilon_1}{4}$. This is the case X in Table 1. The codimension of the orbit is 3, a is modulus.*

Proof : (i) The complete 3-transversal of the germ $(ax^2 + \epsilon_1 y^2 + \epsilon_2 xy + xz, z)$ is $R.\{(xyz, 0), (yz^2, 0)\}$, and the claim follows using Mather's lemma and explicit changes of coordinates in the source and target. The jets $(ax^2 + \epsilon_1 y^2 + \epsilon_2 xy + xz + \epsilon_3 xyz, z)$ and $(ax^2 + \epsilon_1 y^2 + \epsilon_2 xy + xz, z)$ lead to germs of high codimension.

(ii). The calculations in this case are identical to those in Proposition 3.4.1. We show that $l = 3$ and $k = 3$ provided $a \neq 0, \frac{\epsilon_1}{4}$. For the calculations determining k , we have to show that all monomials of degree 6, 5, 4 are in $T_X \mathcal{A}_1.f$ modulo $m_3^7.C_3^{\times 2}$. We have

$$\begin{aligned}x \frac{\partial f}{\partial x} &= (2ax^2 + \epsilon_2xy + xz, 0) \\y \frac{\partial f}{\partial y} &= (2\epsilon_1y^2 + \epsilon_2xy + \epsilon_3yz^2, 0) \\\frac{\partial f}{\partial z} &= (x + 2\epsilon_3yz, 1)\end{aligned}$$

Using $\frac{\partial f}{\partial z}$, we can work modulo $C_3 \cdot \{(0, 1)\}$. One can see that $(xz^5, 0), (yz^5, 0)$ are in $T_X \mathcal{A}_1 \cdot f$ modulo $m_3^7 \cdot C_3^{\times 2}$. A combination of the following vectors $f_1 f_2^3 \cdot \frac{\partial f}{\partial z} - (0, f_1 f_2^3), z^3 x^2 \frac{\partial f}{\partial x}$ and $xyz^3 \frac{\partial f}{\partial y}$ yield $(x^2 z^4, 0) \in T_X \mathcal{A}_1 \cdot f$ modulo $m_3^7 \cdot C_3^{\times 2}$. We obtain the rest of monomials of degree 6 by a suitable combination of the vectors $x \frac{\partial f}{\partial x}$ and $y \frac{\partial f}{\partial y}$ provided $a \neq 0, \frac{\epsilon_1}{4}$. We do the same for degree 5 and 4.

Calculations show that

$$T_X \mathcal{A}_e \cdot f \oplus R \cdot \{(x^2, 0), (x, 0), (y, 0)\} = V(f)$$

The codimension of the orbit of f is then 4. □

1.3.11. Proposition : (i). Any 3-jet with 2-jet $(ax^2 + \epsilon_1xy + xz + \epsilon_2yz, z)$ is equivalent to one of the following: $(ax^2 + \epsilon_1xy + xz + \epsilon_2yz + \epsilon_3y^3, z)$ $(ax^2 + \epsilon_1xy + xz + \epsilon_2yz + \epsilon_3xyz, z)$ or $(ax^2 + \epsilon_1xy + xz + \epsilon_2yz, z)$.

(ii). The orbits in the 4-jet with 3-jet $(ax^2 + \epsilon_1xy + xz + \epsilon_2yz + \epsilon_3y^3, z)$ are $(ax^2 + \epsilon_1xy + xz + \epsilon_2yz + \epsilon_3y^3 + by^4, z), b \in R$.

(iii). The germ $(ax^2 + \epsilon_1xy + xz + \epsilon_2yz + \epsilon_3y^3 + by^4, z)$ is 4- $X\mathcal{A}$ -determined if $a \neq 0, \epsilon_1\epsilon_2, \frac{\epsilon_1\epsilon_2}{2}$. This is the case XI in Table 1, it has codimension 5.

Proof: The proofs of (i) and (ii) follow by looking at the complete transversal together with Mather's lemma and explicit changes of coordinates. The jets $(ax^2 + \epsilon_1xy + xz + \epsilon_2yz + \epsilon_3xyz, z)$ and $(ax^2 + \epsilon_1xy + xz + \epsilon_2yz, z)$ lead to germs of high codimensions.

(iii) Let $f = (ax^2 + \epsilon_1xy + xz + \epsilon_2yz + \epsilon_3y^3 + cy^4, z)$. Then,

$$\begin{aligned}x \frac{\partial f}{\partial x} &= (2ax^2 + \epsilon_1xy + xz, 0) \\y \frac{\partial f}{\partial y} &= (\epsilon_1xy + \epsilon_2yz + 3\epsilon_3y^3 + 4cy^4, 0) \\\frac{\partial f}{\partial z} &= (x + \epsilon_2y, 1)\end{aligned}$$

It is a trivial exercise to show that $m_3^3 \cdot C_3^{\times 2} \subset C_3 \cdot \{x \frac{\partial f}{\partial x}, y \frac{\partial f}{\partial y}, \frac{\partial f}{\partial z}\} + f^* m_2 \cdot C_2^{\times 2} + m_3^4 \cdot C_3^{\times 2}$ provided $a \neq 0$. To prove the statement using Corollary 1.2.3, we need to show that $m_3^5 \cdot C_3^{\times 2} \subset T_X \mathcal{A}_1 \cdot f + m_3^8 \cdot C_3^{\times 2}$. For the monomials of degree 7, all those of

the form $(0, P)$ are in $T_X \mathcal{A}_1.f$ modulo $m_3^8.C_3^{\times 2}$ using $\frac{\partial f}{\partial z}$. The calculations simplify as in Proposition 3.4.2 if one tries to get first all monomials of degree 7 of the form $(zP, 0)$. We notice that $2(f_1 f_2^5, 0) - z^5 x \frac{\partial f}{\partial x} - z^5 y \frac{\partial f}{\partial y} - z^6 \frac{\partial f}{\partial z} = -\epsilon_3(y^3 z^4, 0)$. Therefore $(y^3 z^4, 0) \in T_X \mathcal{A}_1.f$ modulo $m_3^8.C_3^{\times 2}$. A combination of $f_1 f_2^4 \cdot \frac{\partial f}{\partial z} - (0, f_1 f_2^4)$, $x \frac{\partial f}{\partial x}$ and $y \frac{\partial f}{\partial y}$ yield $(2\epsilon_2 x y z^5 + x^2 z^5 + y^2 z^5, 0)$. This vector together with $(f_1 f_2^4, 0) \equiv (a x^2 z^5 + \epsilon_2 x y z^5)$ and $z^5(x y \frac{\partial f}{\partial x} - 2a \epsilon_1 x y \frac{\partial f}{\partial y}) \equiv ((1 - 2a \epsilon_1 \epsilon_2) x y z - \epsilon_2 y^2 z, 0)$ show that $(x y z^5, 0), (x^2 z^5, 0), (y^2 z^5, 0) \in T_X \mathcal{A}_1.f$ modulo $m_3^8.C_3^{\times 2}$ provided $a \neq \epsilon_1 \epsilon_2, \frac{\epsilon_1 \epsilon_2}{2}$. Now we can get all monomials of degree 7 of the form $(P, 0)$ with P divisible by x or z provided $a \neq 0$.

Following the same steps we can show that, provided $a \neq 0, \epsilon_1 \epsilon_2, \frac{\epsilon_1 \epsilon_2}{2}$, all monomials of degree 7, 6, 5, except $(y^7, 0), (y^6, 0), (y^5 z, 0), (y^5, 0), (y^4 z, 0)$, are in $T_X \mathcal{A}_1.f$ modulo $m_3^8.C_3^{\times 2}$.

Using the following vectors:

$$y^6 \frac{\partial f}{\partial z} \equiv (\epsilon_2 y^7, y^6)$$

$$y^5 z \frac{\partial f}{\partial z} \equiv (\epsilon_2 y^5 z, y^4 z)$$

$$(0, f_1^2) \equiv (0, y^6 + 2\epsilon_e \epsilon_3 y^4 z)$$

we deduce that $(y^7, 0), (y^5 z, 0), (0, y^6) \in T_X \mathcal{A}_1.f$ modulo $m_3^8.C_3^{\times 2}$. In order to show that $(y^6, 0)$ and $(y^4 z, 0)$ are in $T_X \mathcal{A}_1.f$ modulo $m_3^8.C_3^{\times 2}$ we use the following vectors (modulo the monomials obtained above): $y^4 \frac{\partial f}{\partial y}, y^2 z \frac{\partial f}{\partial y}, (f_1^2, 0), x^3 \frac{\partial f}{\partial x},$

$$x y z \frac{\partial f}{\partial x}, x y^2 \frac{\partial f}{\partial y}, x^2 y \frac{\partial f}{\partial y}, x z \frac{\partial f}{\partial y}, x^2 z \frac{\partial f}{\partial x}, (a x^2 z + \epsilon_1 x y z + x z^2 + \epsilon_2 y z^2) \frac{\partial f}{\partial z} - (0, f_1 f_2), x z^2 \frac{\partial f}{\partial x} + y z^2 \frac{\partial f}{\partial y} - z^3 \frac{\partial f}{\partial z}.$$

These vectors are linearly independent in the real vector space generated by $\{(x^4, 0), (x^2 y^2, 0), (x^2 z^2, 0), (y^2 z^2, 0), (x^3 y, 0), (x^3 z, 0), (x^2 y z, 0), (x y^2 z, 0), (x y z^2, 0), (y^4 z, 0), (y^6, 0)\}$ if and only if $a \neq 0, \epsilon_1 \epsilon_2, \frac{\epsilon_1 \epsilon_2}{2}$; and therefore for a different from these values $(y^6, 0)$ and $(y^4 z, 0)$ are in $T_X \mathcal{A}_1.f$ modulo $m_3^8.C_3^{\times 2}$.

We have the following: $x z \frac{\partial f}{\partial x} + y z \frac{\partial f}{\partial y} + z^2 \frac{\partial f}{\partial y} - (2f_1 f_2, 0) \equiv (y^3 z, 0)$. Hence, $y^3 \frac{\partial f}{\partial y} \equiv (\epsilon_1 x y^3 + 3\epsilon_3 y^5, 0)$. We can show using $x y^2 \frac{\partial f}{\partial x}$ that $(x y^3 z, 0)$ is in $T_X \mathcal{A}_1.f$ modulo $m_3^8.C_3^{\times 2}$ (since, from the $(y^6, 0)$ calculations, $(x^2 y^2, 0)$ and $(x y^2 z, 0)$ are in $T_X \mathcal{A}_1.f$ modulo $m_3^8.C_3^{\times 2}$). Therefore $(y^5, 0) \in T_X \mathcal{A}_1.f$ modulo $m_3^8.C_3^{\times 2}$.

Calculations show that

$$T_X \mathcal{A}_e.f \oplus R.\{(x^2, 0), (y^4, 0), (x, 0), (y^2, 0)\} = V(f)$$

The codimension of f is 5; a, b, c are moduli. □

The 1-jet $(x + \epsilon_1 y, 0)$

Any 2-jet with 1-jet $(x + \epsilon_1 y, 0)$ is equivalent to $f = (x + \epsilon_1 y + az^2, bx^2 + cxy + dxz + eyz + fz^2)$ for some a, b, c, d, e, f in R . If a, b, f are not zero, we can use linear changes of coordinates so that $f \simeq (x + \epsilon_1 y + \epsilon_2 z^2, x^2 + axy + bxz + cyz + \epsilon_3 z^2)$. The change of coordinate $(x, y, z) \mapsto (x, y, z + \epsilon_3(bx + cy)/2)$ in the source together with Mather's lemma and linear changes of coordinates in the target yield $f \simeq (x + \epsilon_1 y + \epsilon_2 z^2, x^2 + axy + \epsilon_3 z^2)$. One can easily show that any 3-jet with 2-jet $(x + \epsilon_1 y + \epsilon_2 z^2, x^2 + axy + \epsilon_3 z^2)$ is equivalent to $(x + \epsilon_1 y + \epsilon_2 z^2, x^2 + axy + \epsilon_3 z^2 + bx^2 y + cz^3)$ for some b and c in R provided $a \neq 0$.

1.3.12. Proposition : *The germ $(x + \epsilon_1 y + \epsilon_2 z^2, x^2 + axy + \epsilon_3 z^2 + bx^2 y + cz^3)$ is $\mathfrak{3}\text{-}X\mathcal{A}$ -determined provided $a \neq 0, \epsilon_1, b \neq 0, c \neq 0$. It is of codimension 5; a, b, c are moduli. This is the case XII in Table 1.*

The calculations for this Proposition are similar to those above. In this case $l = 2$ and $k = 3$ for $a \neq 0, \epsilon_1, b \neq 0, c \neq 0$.

§4. The Geometry of the projections

The Table 1 given in Theorem 1 can be divided into three parts: I- VI, VII- VIII and IX- XII. The first part contains germs of submersions which map the crease smoothly into its image, the cases VII and VIII are germs of submersions and the image of the crease is singular. The remaining cases are germs of maps of rank 1 and their unfolding cannot be realized as a family of orthogonal projections of generic piecewise-smooth surfaces.

For germs in the first part one can see that the surface X_1 does not contribute to the geometry of the germs (since $f|_{X_1}$ is a submersion). These germs can be deduced from Table 1 in [B-G4] as follows.

Let $f: R^3, 0 \longrightarrow R^2, 0$ be a germ of a *submersion*.

1.4.1. Lemma : *If f is an immersion on the crease then it is $X\mathcal{A}$ -equivalent to $(\epsilon x + g(y, z), z)$ or $(\epsilon y + g(x, z), z)$ with $\epsilon = \pm 1$.*

Proof : Since $\frac{\partial f}{\partial z}(0,0,0) \neq 0$, we can write locally $f(x,y,z) = (f_1(x,y,z), az + f_2(x,y,z))$ with $a \neq 0$. The change of coordinates $(\acute{x}, \acute{y}, \acute{z}) = (x, y, az + f_2(x,y,z))$ in the source yields the following $X\mathcal{A}$ -equivalent germ to f (denoted also by f and dropping dashes): $f(x,y,z) = (\tilde{f}(x,y,z), z)$. Since f is a germ of a submersion $\frac{\partial \tilde{f}}{\partial x}(0,0,0) \neq 0$ or $\frac{\partial \tilde{f}}{\partial y}(0,0,0) \neq 0$.

Suppose that $\frac{\partial \tilde{f}}{\partial x}(0,0,0) \neq 0$, so that we can write $f(x,y,z) = (bx + xh(x,y,z) + g(y,z), z)$ with $h(0,0,0) = 0$. By the explicit change of coordinates in the source $(\acute{x}, \acute{y}, \acute{z}) = (\text{sign}(b)(bx + xh(x,y,z), y, z)$ f is $X\mathcal{A}$ -equivalent to $(\epsilon x + g(y,z), z)$. And similarly if $\frac{\partial \tilde{f}}{\partial y}(0,0,0) \neq 0$ then $f \simeq (\epsilon y + g(x,z), z)$. \square

1.4.2. Theorem : *The germ $(\epsilon x + g(y,z), z)$ is $k - X\mathcal{A}_1$ -determined if and only if the germ $(g(y,z), z)$ is $k - \mathcal{B}_1$ -determined.*

\mathcal{B} is the group of pairs of diffeomorphisms (h, k) acting on $C_2^{\times 2}$ with h preserving the x -axis [B-G4].

Proof : Let $F(x,y,z) = (\epsilon x + g(y,z), z)$ and $f(y,z) = (g(y,z), z)$. It is clear that $\frac{\partial F}{\partial y}(x,y,z) = \frac{\partial f}{\partial y}(y,z)$ and $\frac{\partial F}{\partial z}(x,y,z) = \frac{\partial f}{\partial z}(y,z)$. Using the expression for the tangent space of the $X\mathcal{A}$ -orbit of F and of the \mathcal{B} -orbit of f we get:

$$\begin{aligned} T_X\mathcal{A}.F &= C_3(x,y,z) \cdot \left\{ x \frac{\partial F}{\partial x}, y \frac{\partial F}{\partial y}, x \frac{\partial F}{\partial z}, y \frac{\partial F}{\partial z}, z \frac{\partial F}{\partial z} \right\} + F^*m_2\{e_1, e_2\} \\ &= C_3(x,y,z) \cdot \left\{ (\epsilon x, 0), x \left(\frac{\partial g}{\partial x}, 1 \right) \right\} + C_3(x,y,z) \cdot \left\{ y \frac{\partial f}{\partial y}, y \frac{\partial f}{\partial z}, z \frac{\partial f}{\partial z} \right\} + F^*m_2\{e_1, e_2\} \\ &= C_3(x,y,z) \cdot \{(x, 0), (0, x)\} + C_2(y,z) \cdot \left\{ y \frac{\partial f}{\partial y}, y \frac{\partial f}{\partial z}, z \frac{\partial f}{\partial z} \right\} + f^*m_2\{e_1, e_2\} \\ &= C_3(x,y,z) \cdot \{(x, 0), (0, x)\} + T\mathcal{B}.f \end{aligned}$$

Therefore,

$$m_3^{k+1}.C_3^{\times 2} \subset T_X\mathcal{A}.F \iff m_2^{k+1}.C_2^{\times 2} \subset T\mathcal{B}.f$$

and

$$m_3^{k+1}.C_3^{\times 2} \subset T_X\mathcal{A}_1.F \iff m_2^{k+1}.C_2^{\times 2} \subset T\mathcal{B}_1.f$$

We conclude using Theorem 2.5 in [B-dP-W]. \square

1.4.3. Remark : It follows from the relation between the tangent spaces to the orbits of F and f given in the proof of Theorem 3.2, that $V(F)/T_X\mathcal{A}_e.F = V(f)/T_X\mathcal{B}_e.f$.

If ϕ_1, \dots, ϕ_p form a basis of the real vector space $V(F)/T_X \mathcal{A}_e.F$, then $F + \sum_{i=1}^q \lambda_i \phi_i$ is a versal unfolding of F and $f + \sum_{i=1}^q \lambda_i \phi_i$ is a versal unfolding of f .

Geometrically, when the two surfaces meet transversally and the projection of the crease is smooth, one of them can be ignored and one has to consider only the projection of the remaining surface with boundary. Although one of the pieces of surfaces has no effect on the geometry, the side in which it is positioned with respect to the other surface gives rise to two different orbits (this is reflected by the sign ϵ attached to x in Table 1). This situation occurs in the cases I- VI. Their geometrical interpretation can be deduced from [B-G4].

We shall give a versal unfolding of each germ in Table 1, and a “realization” of it in terms of a family of parallel projections of immersed piecewise-smooth surfaces in R^3 (for cases I- VIII) or in terms of a family of projections of a family of piecewise-smooth surfaces (for cases IX- XII), explain geometrically how each case occurs, describe the “critical locus” of the germ and draw a picture of critical loci of nearby germs by varying the unfolding parameters.

We denote by Σ_1 and Σ_2 the sets of critical points of the maps $f|_{X_1}$ and $f|_{X_2}$ respectively, and write $\Delta_1 = f(\Sigma_1), \Delta_2 = f(\Sigma_2)$. The set $\{(0, 0, z)\}$ is called the *crease* and is denoted by C . The *critical set* of f is $\Sigma = \Sigma_1 \cup \Sigma_2 \cup C$. The *critical locus* of f is the image of the critical set, that is $f(\Sigma) = \Delta_1 \cup \Delta_2 \cup f(C)$. The image of the crease is drawn with a thick line. If we denote by X'_2 the set $\{(0, y, z): y < 0\}$, and by Σ'_2 the critical set of $f|_{X'_2}$, then $f(\Sigma'_2)$ which is referred to as the “invisible” part of the profile, is sometimes drawn with a ‘dashed line’ and sometimes omitted. The profile Δ_1 is drawn with a dotted line. When changing the signs of ϵ_i , the pictures remain essentially identical apart from reflexions through the origin or with respect to the axis, or by interchanging the dashed and the undashed parts. We shall draw the pictures for $\epsilon_i = +1$.

1.4.4. Remarks : Locally at the origin:

(1) The image of the crease $f(C)$ and the profiles are tangential where they meet. (This follows from the fact that if $f|_{X_i}$ is singular at the origin it maps all curves to tangential ones.)

(2) If f is a submersion and $f(C)$ is smooth, then at most one of the profiles is non-empty. (With the hypothesis it is a consequence of Lemma 3.1 that $f|_{X_1}$ or $f|_{X_2}$ is a submersion.)

(3) If $f(C)$ is singular then both profiles are non-empty. ($f(C)$ singular implies $f|_{X_1}$ and $f|_{X_2}$ are both singular.)

1.4.5. Versal unfolding and realization

As pointed out in remarks following Definition 1.2.1, for a k -determined jet we can consider the induced action of ${}_X\mathcal{A}$, hence that of ${}_X\mathcal{A}_e$, on $J^k(3,2)$. Let P be a plane transversal to the ${}_X\mathcal{A}_e$ orbit of f in $J^k(3,2)$. If P is generated by (u_1, \dots, u_p) and $P \oplus J^k(T_X\mathcal{A}_e) = J^k(3,2)$ then

$$F : R^3 \times R^p \longrightarrow R^2$$

$$(x, y, z, u_1, \dots, u_p) \longmapsto f(x, y, z) + \sum_{i=1}^p \lambda_i u_i$$

is a versal unfolding of f . (Indeed, the condition P transverse to $T_X\mathcal{A}_e.f$ implies that $j^k F$ is transverse to the orbit of f and therefore F is versal.)

The family F contains all nearby germs to f in the sense that for any germ g near f there is a p -tuple of scalars $(\lambda_1, \dots, \lambda_p)$ for which $F(-, \lambda_1, \dots, \lambda_p)$ is ${}_X\mathcal{A}$ -equivalent to g . This is also to say that the orbit of g hits the plane P at $\lambda_1 u_1 + \dots + \lambda_p u_p$.

For a given versal unfolding (with 2 parameters), it is interesting to find an immersed piecewise-smooth surface M for which the 2-parameter family of parallel projections on a fixed plane realizes this versal unfolding. If

$$i : R^3, 0 \longrightarrow R^3, 0$$

$$(x, y, z) \longmapsto (X(x, y, z), Y(x, y, z), Z(x, y, z))$$

is an immersion, then the image of the model of piecewise-smooth surface $X = X_1 \cup X_2$ is denoted by M . We write $M = M_1 \cup M_2$ with $M_j = i(X_j), j = 1, 2$. Suppose that M is viewed in the $(0,0,1)$ direction, then all nearby directions can be parametrized by $(-\lambda, -\mu, 1)$ for λ and μ closed to 0. Projecting M onto the plane $z = 0$ gives a family of maps $G: R^3 \times R^2, 0 \longrightarrow R^2, 0$ with $G(x, y, z, \lambda, \mu) = (X + \lambda Z, Y + \mu Z)$ as follows:

$$R^3, 0 \times R^2, 0 \begin{array}{c} \xrightarrow{i} \\ \xrightarrow{G} \end{array} \begin{array}{c} R^3, 0 \\ \downarrow \pi_{(-\lambda, -\mu)} \\ R^2, 0 \end{array}$$

Here $\pi_{(-\lambda, -\mu)}$ denotes the projection on $z = 0$ in the direction $(-\lambda, -\mu, 1)$. Note that when $\lambda = \mu = 0$, $\pi_{(0,0)} \circ i = (X, Y) = f$ is the initial germ.

Any 1-parameter unfolding with unfolding monomials Z such that (X, Y, Z) is an immersion can be trivially realized by putting $\lambda = 0$ (or $\mu = 0$).

The cases IX, X, XI, XII in Table 1 cannot be realized as a family of projections of a generic piecewise-smooth surfaces. We consider instead a 1-parameter family of projections $\pi_{(0, -\mu)}$ of a 1-parameter family $M_\lambda = i_\lambda(X)$ of piecewise-smooth surfaces. The family of surfaces has the property that at $\lambda = 0$ the two pieces of surface have a common tangent plane at the origin. The versal unfoldings of the germs can be recovered by $\pi_{(0, -\mu)} \circ i_\lambda$.

1.4.6. The geometry of the normal forms in Table 1

Case I. Trivial crease.

The germ is stable. It is realized by $(\epsilon x + y, z, y)$. The critical locus consists locally of the line $\{(0, z), z \in R\}$.

Case II. Semi-fold.

The germ is stable. It can be realized by $(\epsilon x + y^2 + yz, z, y)$. The direction $(0,0,1)$ is tangent to the surface M_2 and is transverse to Σ_2 and C . Σ_1 is empty (figure 1.4.1).

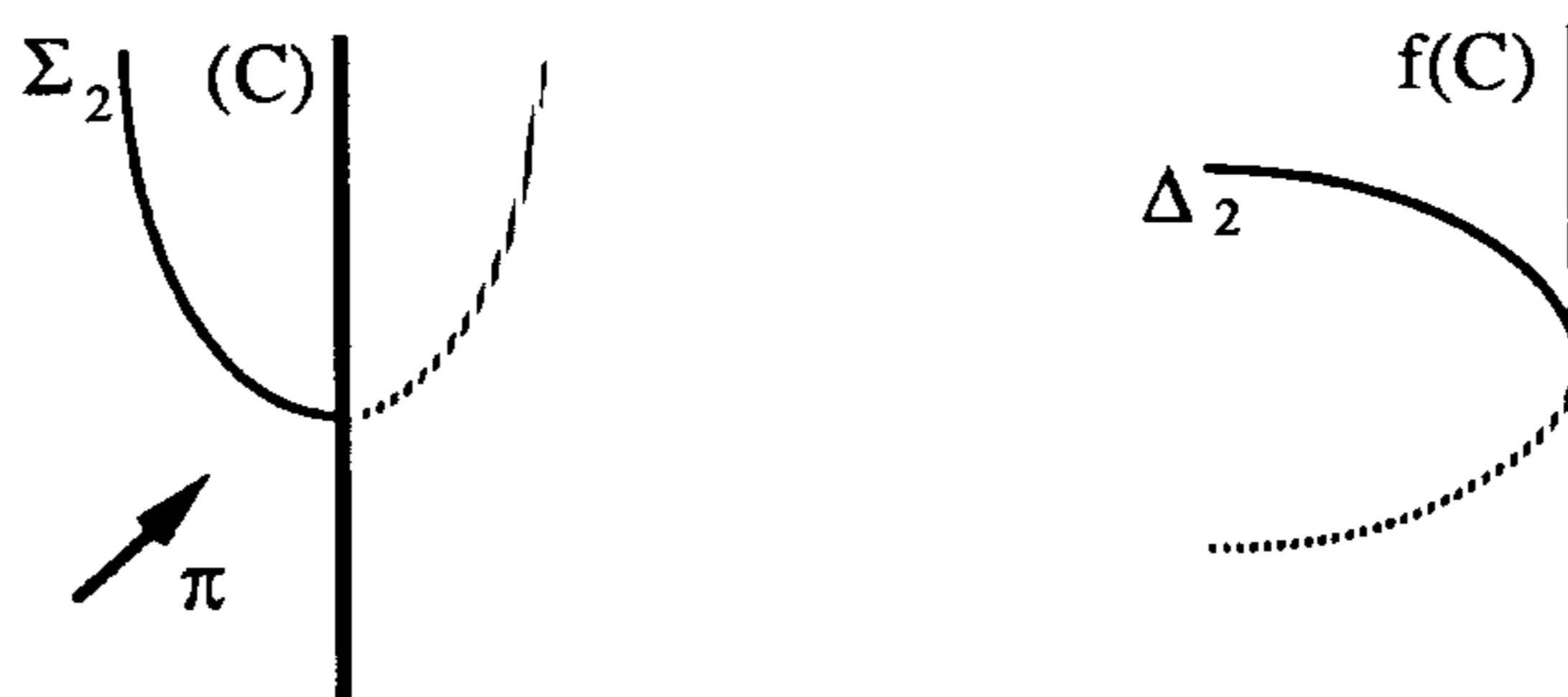

Figure 1.4.1. Semi-fold

Case III.a $k = 2$. Semi-lips/beaks (C-lips/beaks in [C])

A versal unfolding is $(\epsilon x + y^2 + \epsilon_1 yz^2 + \lambda y, z)$. It is realized by $i(x, y, z) = (\epsilon x + y^2 + \epsilon_1 yz^2, z, y)$. The point $(0,0,0)$ is a parabolic point on the surface M_2 , $(0,0,1)$ is tangent to M_2 but is not an asymptotic direction. The crease C and Σ_2 are tangential when $\lambda = 0$. Σ_1 is empty.

To get a parametrization of Σ_2 , we consider the map $(y, z) \mapsto (y^2 + \epsilon_1 yz^2 + \lambda y, z)$. It is singular when $2y + \epsilon_1 z^2 + \lambda = 0$, equivalently $y = -\frac{1}{2}(\epsilon_1 z^2 + \lambda)$. So $\Sigma_2 = \{(0, -\frac{1}{2}(\epsilon_1 z^2 + \lambda), z), z \in R\}$. The profile Δ_2 is parametrized by $z \mapsto (-\frac{1}{4}(\epsilon_1 z^2 + \lambda)^2, z)$. The critical locus undergoes semi-lips transition when $\epsilon_1 = +1$ and a semi-beaks transition when $\epsilon_1 = -1$ (figure 1.4.2).

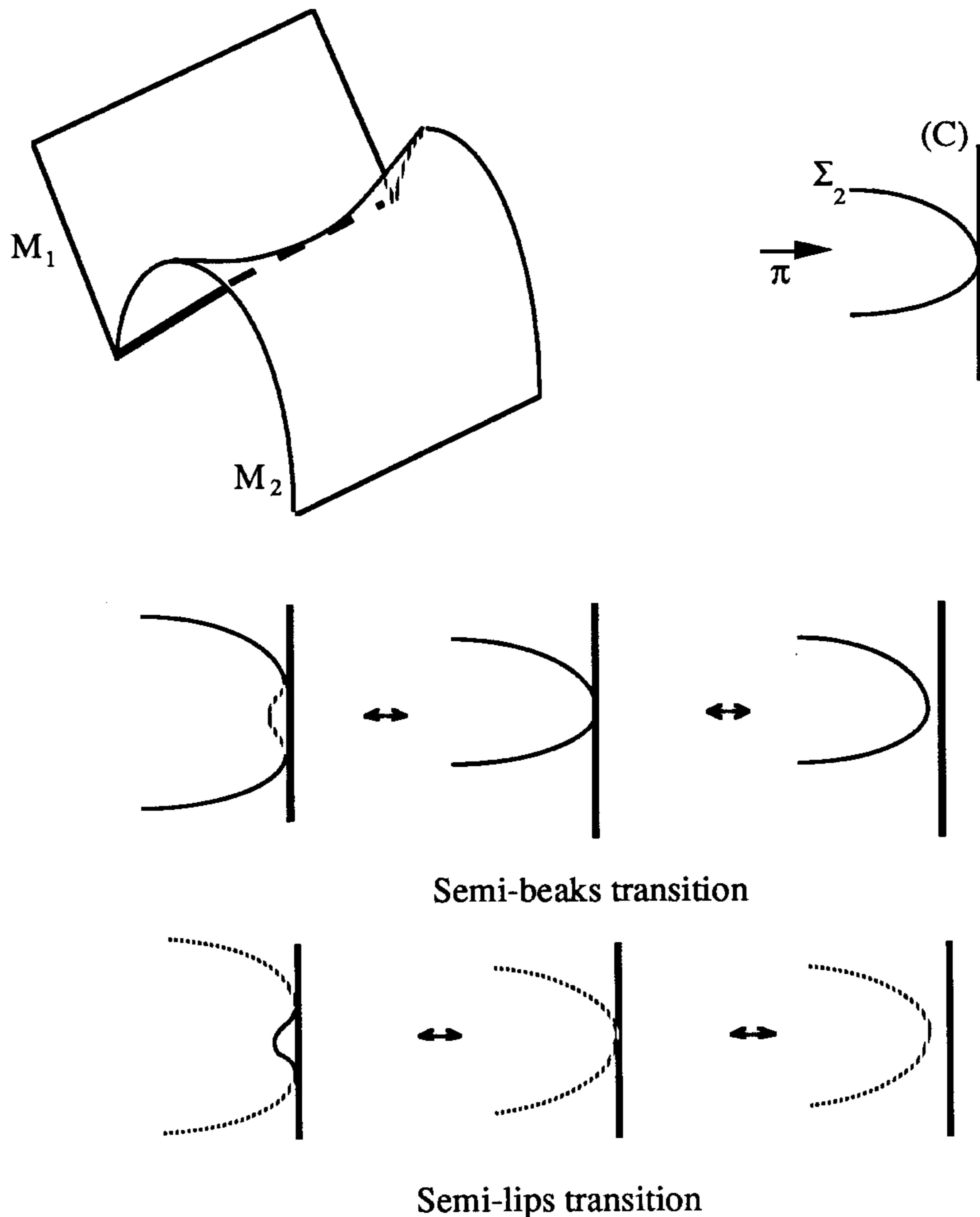

Figure 1.4.2. Semi-lips/beaks

Case III.b. $k = 3$ Semi-goose (c-goose in [C])

A vesal unfolding is $(\epsilon x + y^2 + yz^3 + \lambda y + \mu yz, z)$. This germ cannot be realized as a family of orthogonal projections of an immersed piecewise-smooth surface. We consider instead the following equivalent germ $(\epsilon x + z^2 + y^2 + yz^3, z)$. Its $\chi\mathcal{A}$ versal unfolding is $(\epsilon x + z^2 + y^2 + yz^3 + \lambda(y + yz), z + \mu(y + yz))$ which can be realized by the immersion $i(x, y, z) = (\epsilon x + z^2 + y^2 + yz^3, z, y + yz)$.

The point $(0,0,0)$ is not a parabolic point on the surface M_2 . $(0,0,1)$ is not an asymptotic direction, it is transverse to C . Σ_1 is empty, Σ_2 and C have 3 point-contact. In fact Σ_2 has an inflexion at the origin when $\lambda = \mu = 0$. This case occurs at isolated point on the crease.

If we consider the first given unfolding, we can easily compute Σ_2 for a fixed (λ, μ) . We find $\Sigma_2 = \{(0, -\frac{1}{2}(\lambda + \mu z + z^3), z), z \in R\}$ and $\Delta_2 = \{(-\frac{1}{4}(\lambda + \mu z + z^3)^2, z), z \in R - \frac{1}{2}(\lambda + \mu z + z^3) \geq 0\}$.

There is a special curve in the unfolding parameters where, for a fixed point on it, the germ has singularities of type III.a in Table 1. This occurs when the crease C and Σ_2 have 2 point-contact. Algebraically this means $\lambda + \mu z + z^3 = 0$ and $\mu + 3z^2 = 0$. Thus, $(\lambda, \mu) = (2z^3, -3z^2)$. This curve has an ordinary cusp at the origin. On one branch of the cusp semi-lips occurs and on the other it is the occurrence of semi-beaks (figure 1.4.3).

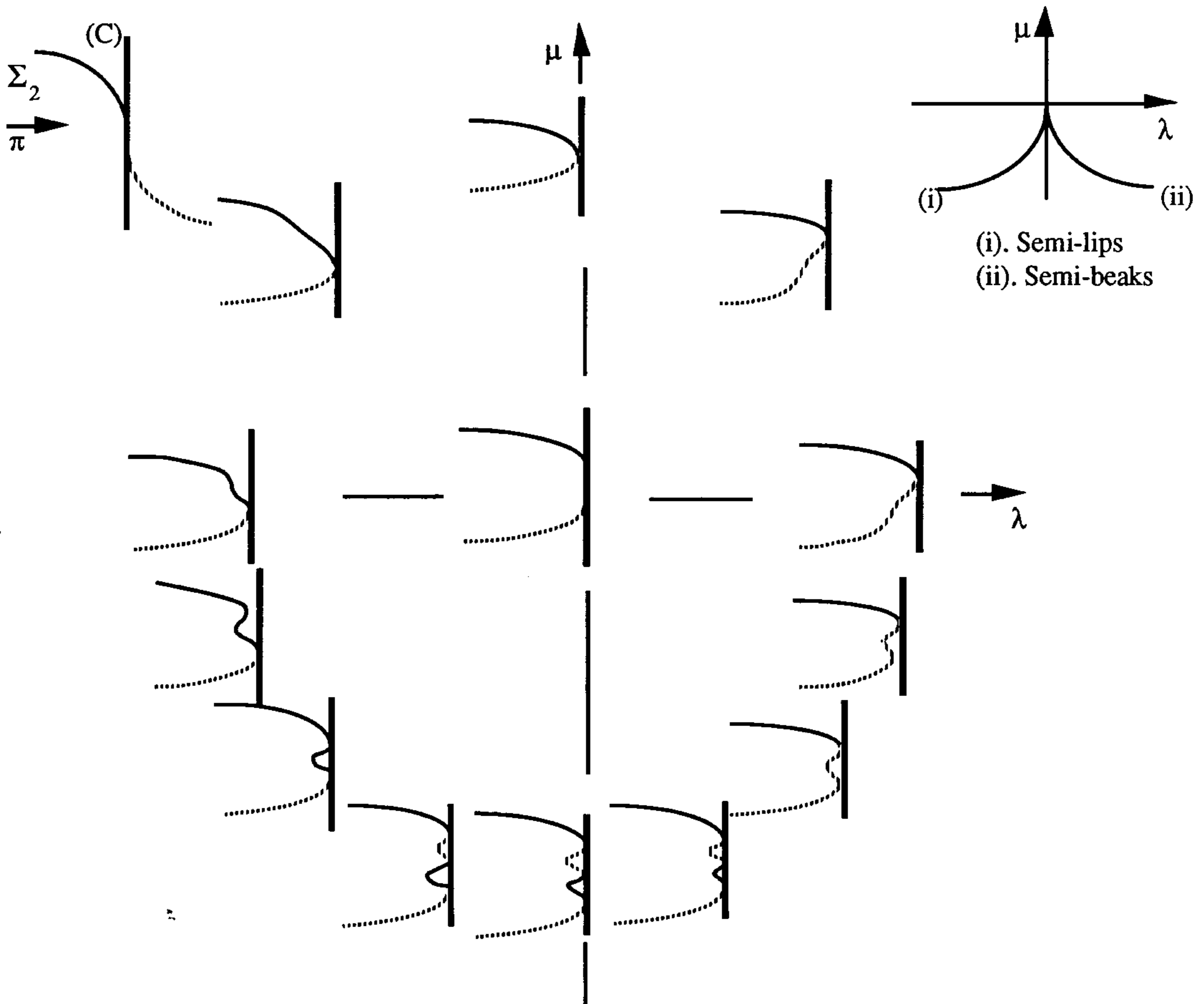

Figure 1.4.3. Semi-goose

Case IV Semi-cusp (C-swallowtail in [C])

An $\chi\mathcal{A}$ -versal unfolding of the germ is given by $(\epsilon x + yz + y^3 + \lambda y, z)$. It is realized by $i(x, y, z) = (\epsilon x + yz + y^3, z, y)$. The image of the crease is smooth, Σ_1 is empty, $(0,0,1)$ is an asymptotic direction at $(0,0,0)$ on M_2 . Σ_2 and C are transverse.

For a fixed λ , $\Sigma_2 = \{(0, y, -\lambda - 3y^2), y \geq 0\}$ and $\Delta_2 = \{(\lambda y^2 - 2y^3, 2\lambda y - 3y^2)\}$. The profile Δ_2 has an ordinary cusp which lies on the image of the crease when $\lambda = 0$. The cusp moves from one side of the image of the crease to the other when λ change sign (figure 1.4.4). Singularities of type II in Table 1 occur when $\lambda \neq 0$.

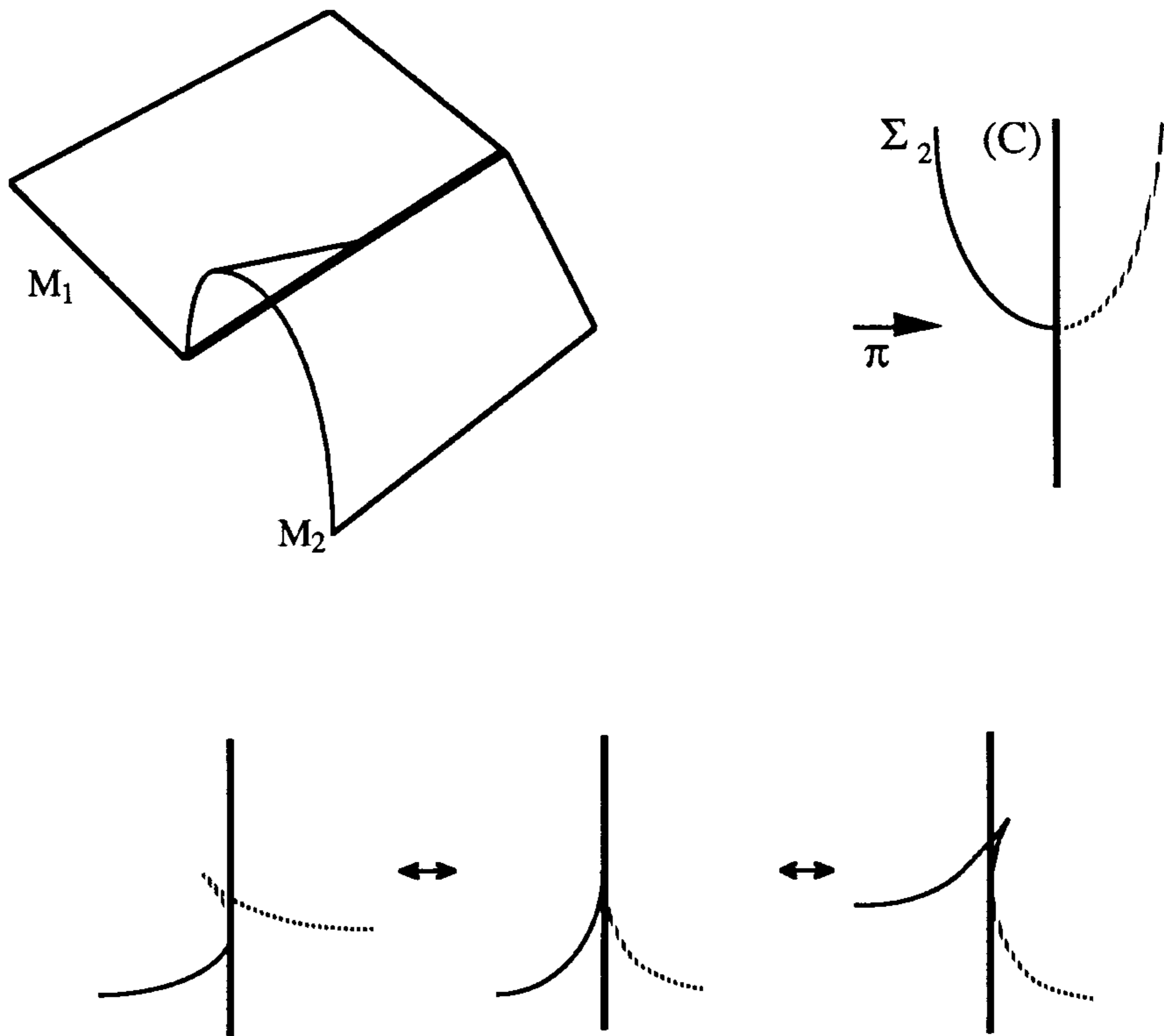

Figure 1.4.4. Semi-cusp

Case V Semi-swallowtail (Swallowtail horizon in [C])

An $\mathcal{X}\mathcal{A}$ -versal unfolding of the germ is $(\epsilon x + yz + y^4 + \epsilon_1 y^6 + \lambda y^2 + \mu y^3, z)$. An unfolding with symmetrical monomials is $(\epsilon_1 x + yz + y^4 + \epsilon_1 y^6 + \lambda(y + y^3), z + \mu(y + y^3))$ and can be realized by $(\epsilon x + yz + y^4 + \epsilon_1 y^6, z, y + y^3)$.

$(0,0,1)$ has 4 point-contact with M_2 at $(0,0,0)$. Σ_2 and C are transverse. Taking the first given unfolding, for a fixed (λ, μ) , $\Sigma_2 = \{(0, y, -2\lambda y - 3\mu y^2 - 4y^3 - 6\epsilon_1 y^5), y \geq 0\}$ and $\Delta_2 = \{(-\lambda y^2 - 2\mu y^3 - 3y^4 - 5\epsilon_1 y^6, -2\lambda y - 3\mu y^2 - 4y^3 - 6\epsilon_1 y^5), y \geq 0\}$.

At $\lambda = \mu = 0$, the profile Δ_2 has a $(3,4)$ singularity (*i.e.* equivalent to (y^3, y^4) as a curves). There is a special curve in the unfolding parameters where, for (λ, μ) fixed, the germ has singularities of type IV in Table 1. At such points the direction of projection $(-\lambda, -\mu, 1)$ is an asymptotic direction to M_2 at a point on the crease. The profile Δ_2 has a cusp which lies on crease (figure 1.4.5). Calculations show that this occurs on the curve $(\lambda, \mu) = (3y^2 + 15\epsilon_1 y^3, -3y - 10\epsilon_1 y^3)$.

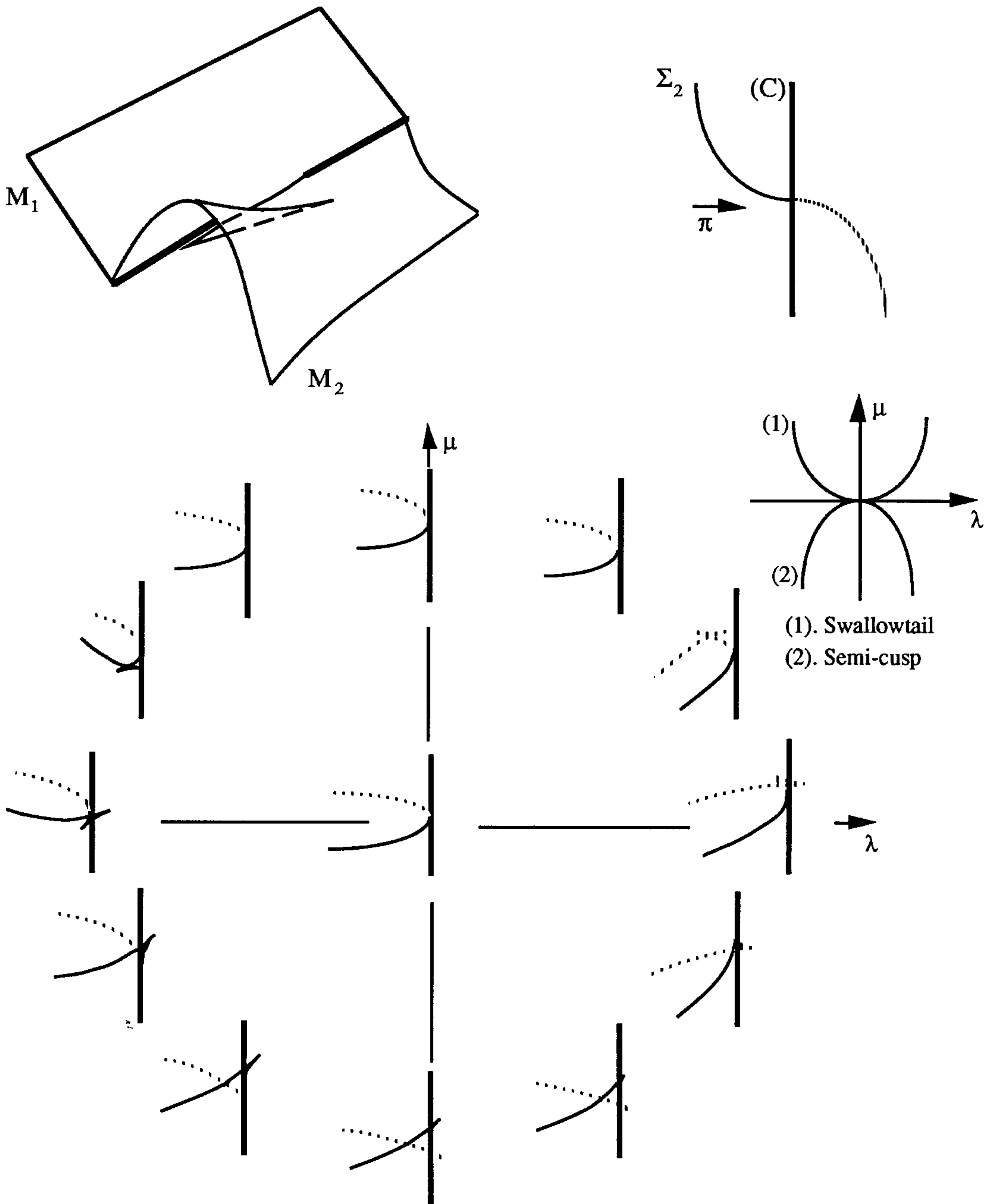

Figure 1.4.5. Semi-swallowtail

Case VI Lips/beaks on crease (Lips/beaks horizon in [C])

An $\mathcal{X}\mathcal{A}$ -versal unfolding is $(\epsilon x + yz^2 + y^2z + ay^3 + \epsilon_1 y^4 + \lambda y + \mu y^2, z)$. This unfolding cannot be realized. We consider instead of the normal form given in Table 1 the following equivalent germ to it: $(\epsilon x + z^2 + yz^2 + y^2z + ay^3 + \epsilon_1 y^4, z)$. It has the following symmetrical unfolding: $(\epsilon x + z^2 + yz^2 + y^2z + ay^3 + \epsilon_1 y^4 + \lambda(y + y^2), z + \mu(y + y^2))$ which can be realized by $i(x, y, z) = (\epsilon x + z^2 + yz^2 + y^2z + ay^3 + \epsilon_1 y^4, z, y + y^2)$.

$(0,0,0)$ is a parabolic point on the surface M_2 and $(0,0,1)$ is its asymptotic direction. $(0,0,1)$ is transverse to the crease C . Using the first given versal unfolding the critical set Σ_2 consists of a node when $1-3a > 0$ and an isolated point when $1-3a < 0$. In fact Σ_2 is the set of points $(0, y, z)$ with $\lambda + 2\mu y + z^2 + 2yz + 3ay^2 + 4\epsilon_1 y^3 = 0$. We shall write $\phi(y, z) = \lambda + 2\mu y + z^2 + 2yz + 3ay^2 + 4\epsilon_1 y^3$.

There is a curve in the (λ, μ) -parameter space where singularities of type III.a occur. This happens when Σ_2 is tangent to the crease, that is $y = 0$ and $\frac{\partial \phi}{\partial z} = 0$ which turns out to be $\lambda = 0$. (figure 1.4.6.)

There is another curve where singularities of type IV occur. It happens when the viewing direction is tangent to Σ_2 and is transversal to the crease. The conditions for this are $y = 0$ and Δ_2 is singular, that is $y = 0$ and $\frac{\partial \phi}{\partial y} = 0$. This yields $\lambda + \mu^2 = 0$. (figure 1.4.6.)

There is also a special curve in the (λ, μ) parameter where lips/beaks occur on Δ_2 but the corresponding points on the surface do not lie on the crease. It happens when Σ_2 is itself singular and the singularity is not on C . Algebraically these conditions are expressed as follow:

$$\phi = \lambda + 2\mu y + z^2 + 2yz + 3ay^2 + 4\epsilon_1 y^3 = 0 \quad \frac{\partial \phi}{\partial y} = \frac{\partial \phi}{\partial z} = 0 \quad \text{and} \quad y \neq 0.$$

Solving these equations for λ and μ we get

$$(\lambda, \mu) = (-(1-3a)y^2 + 8\epsilon_1 y^3, (1-3a)y - 6\epsilon_1 y^2)$$

Notice that this curve has an ordinary cusp when $y = (1-3a)/12$. This cusp is at the origin when $a = 1/3$.

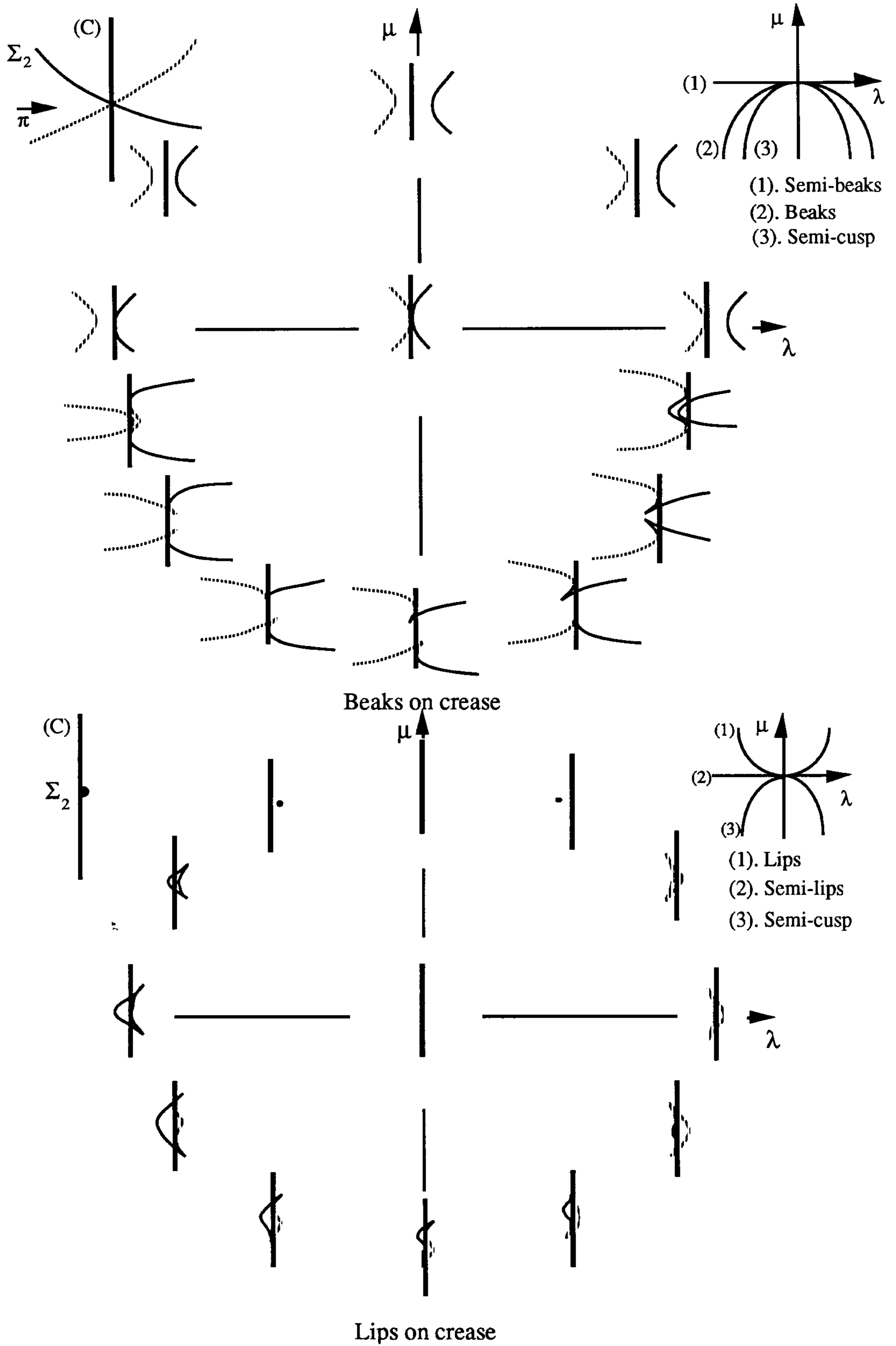

Figure 1.4.6. Lips/beaks on crease

Case VII.a Crease cusp (Edge-on in [C])

An $\mathcal{X}\mathcal{A}$ -versal unfolding is $(x + \epsilon_1 z^2 + z^3 + \lambda z, y + \epsilon_2 z^2)$ and realized by $(x + \epsilon_1 z^2 + z^3, y + \epsilon_2 z^2, z)$.

$(0,0,1)$ is tangent to the crease. The sets Σ_1 and Σ_2 are both transverse to the crease. We have $\Sigma_1 = \{(x, 0, 0), x \geq 0\}$, $\Sigma_2 = \{(0, y, 0), y \geq 0\}$, $\Delta_1 = \{(x, 0), x \geq 0\}$ and $\Delta_2 = \{(0, y), y \geq 0\}$. The image of the crease is parametrized by $z \mapsto (\epsilon_1 z^2 + z^3 + \lambda z, \epsilon_2 z^2)$. When $\lambda = 0$, the image of the crease has an ordinary cusp (figure 1.4.7 (i) when $\epsilon_1 = \epsilon_2 = +1$, and (ii) when $\epsilon_1 = -\epsilon_2 = +1$).

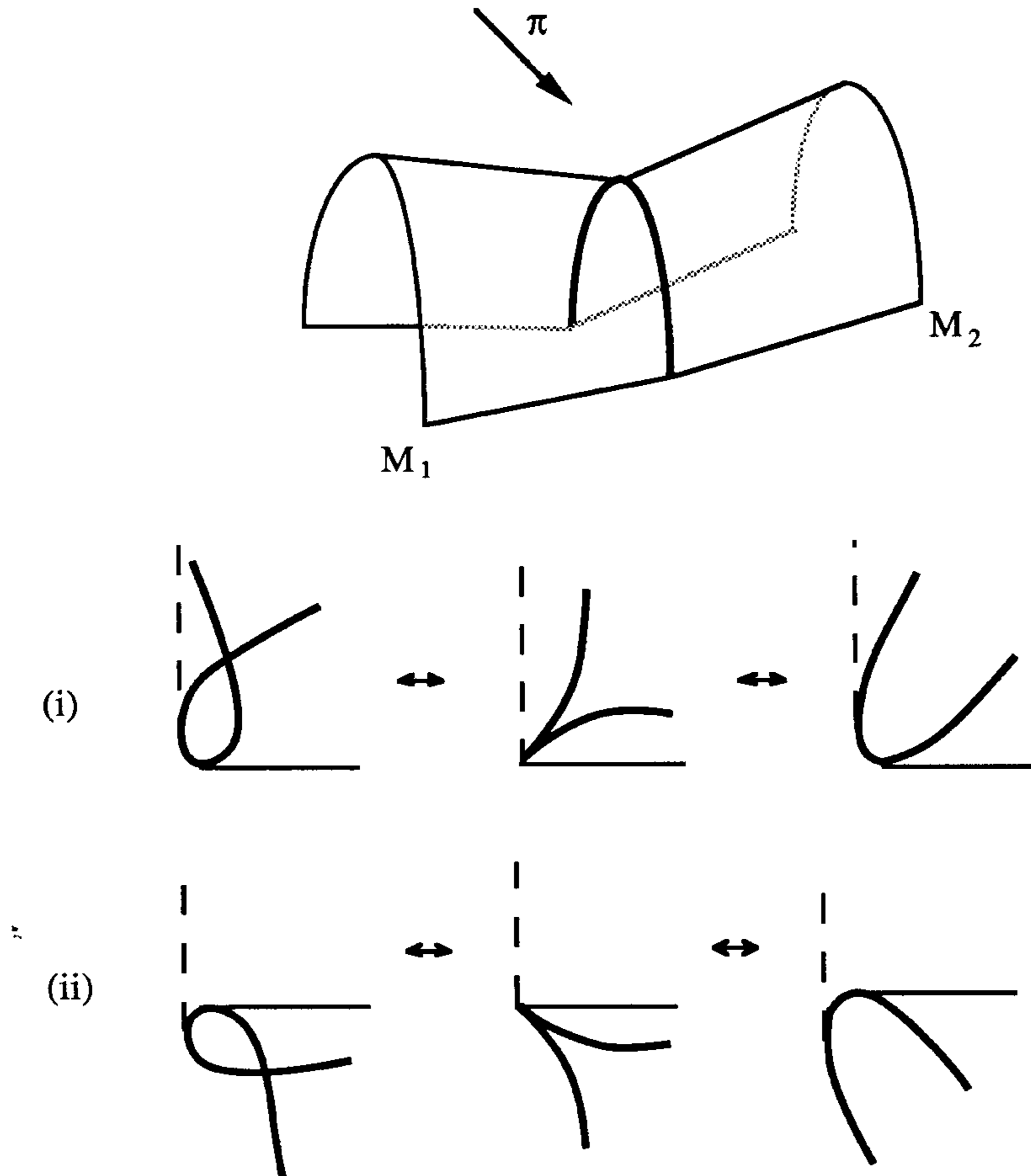

Figure 1.4.7. Crease cusp

Case VII.b Crease rhamphoid cusp (rhamphoid edge on [C])

An $\mathcal{X}\mathcal{A}$ -versal unfolding is $(x + \epsilon_1 z^2 + z^5 + \lambda z + \mu z^3, y + \epsilon_2 z^2)$. An equivalent germ to that given in Table 1 can be realized by $i(x, y, z) = (x + \epsilon_1 z^2 + z^4 + z^5, y + \epsilon_2 z^2, z - z^3)$.

$(0,0,1)$ is tangent to the crease at a point of a zero torsion. $(0,0,1)$ is not an asymptotic direction to M_1 or M_2 . Taking the first versal unfolding $\Sigma_1 = \{(x, 0, 0), x \geq$

$0\}$, $\Sigma_2 = \{(0, y, z_0), y \geq 0, \lambda + 3\mu z_0^2 + 2\epsilon_1 \epsilon_2 z_0 + 5z_0^4 = 0\}$, $\Delta_1 = \{(x, 0), x \geq 0\}$ and $\Delta_2 = \{(\epsilon_1 z_0^2 + z_0^5 + \lambda z_0 + \mu z_0^3, y + \epsilon_2 z_0^2), y \geq 0\}$.

The crease is given by $(\epsilon_1 z^2 + z^5 + \lambda z + \mu z^3, y + \epsilon_2 z^2)$. When $\lambda = \mu = 0$ the image of the crease has a rhamphoid cusp. On the μ -axis it has an ordinary cusp (singularity of type VII.a). On the curve $\delta : \mu^2 - 4\lambda = 0$ for $\mu \leq 0$ the image of the crease has two tangential branches, in the area delimited by δ and the negative μ -axis it has 2 points of self intersection, in the negative λ region there is one point of self intersection and no point of self intersection in the remaining area (figure 1.4.8).

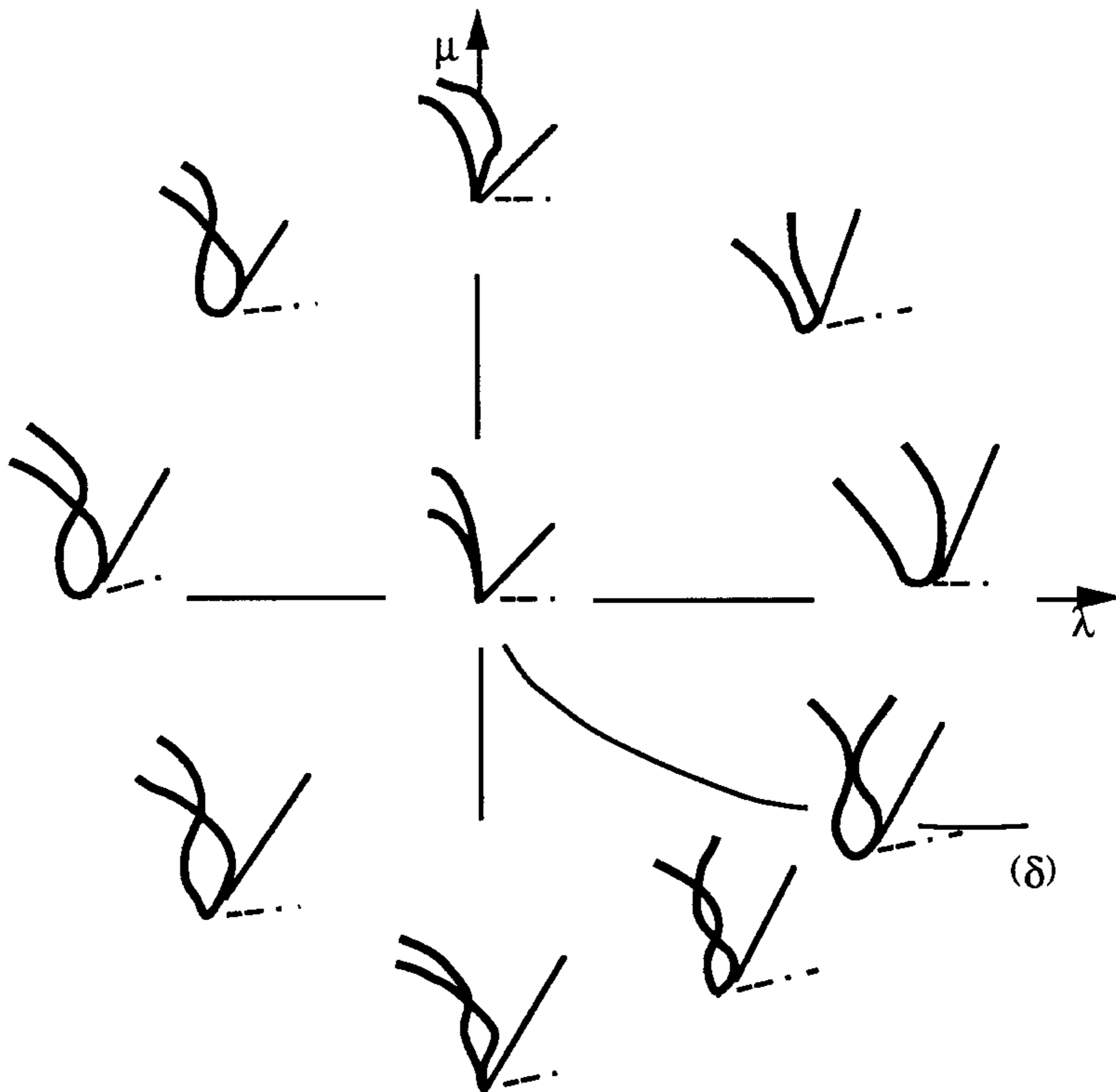

Figure 1.4.8. Crease rhamphoid cusp

Case VIII Double cusp (C-ruffle in [C])

An $\mathcal{X}\mathcal{A}$ -versal unfolding is $(x + yz + az^3 + \epsilon_1 z^4 + bz^5 + \lambda z, y + \epsilon_2 z^2 + \mu z)$. For fixed a, b different from the exceptional values given in Theorem 1 this versal unfolding can be realized by $(x + yz + az^3 + \epsilon_1 z^4 + bz^5, y + \epsilon_2 z^2, z)$.

At $(0,0,0)$, $(0,0,1)$ is tangent to the crease and is an asymptotic direction to the surface M_2 ; both the profile Δ_2 and the image of the crease have cusps. The image of the crease is parametrized by $z \mapsto (az^3 + \epsilon_1 z^4 + bz^5 + \lambda z, \mu z + \epsilon_2 z^2)$. The profile Δ_1 is a line touching the image of the crease at $(\frac{-1}{8}a\epsilon_2\mu^3 + \frac{\epsilon_1}{16}\mu^4 - \frac{\epsilon_2}{32}b\mu^5 - \frac{\epsilon_2}{2}\lambda\mu, \frac{\epsilon_2}{4}\mu^2)$. The critical set Σ_2 is the set of points $(0, y, z)$ where the map $(y, z) \mapsto (yz + az^3 + \epsilon_1 z^4 + bz^5 + \lambda z, y + \epsilon_2 z^2 + \mu z)$ is singular, that is the set of points (y, z) such that

$$y = -\lambda + \mu z - (3a - 2\epsilon_2)z^2 - 4\epsilon_1 z^3 - 5bz^4 \quad (\star)$$

The profile Δ_2 is then parametrized by:

$$z \mapsto (\mu z^2 - 2(a - \epsilon_2)z^3 - 3\epsilon_1 z^4 - 4bz^5, -\lambda + 2\mu z - 3(a - \epsilon_2)z^2 - 4\epsilon_1 z^3 - 5bz^4)$$

At $\lambda = \mu = 0$, the profile Δ_2 has an ordinary cusp if $a \neq \epsilon_2$. It has a singularity of type (3,4) when $a = \epsilon_2$.

There are special curves in the (λ, μ) -parameter space where singularities of type III, IV and VIIa occur.

(i). *Singularities of type III*. Semi-lips/beaks occur when the critical set Σ_2 and the crease C are tangential. In the equation (\star) this is expressed by $y = \frac{\partial y}{\partial z} = 0$. Solving these equations yields

$$(\lambda, \mu) = ((3a - 2\epsilon_2)z^2 + 8\epsilon_1 z^3 + 15bz^4, 2(3a - 2\epsilon_2)z + 12\epsilon_1 z^2 + 20bz^3)$$

This curve has a cusp at z_0 satisfying $(3a - 2\epsilon_2) + 12\epsilon_1 z_0 + 30bz_0^2 = 0$. When $a = \frac{2}{3}\epsilon_2$ this cusp lies at the origin.

(ii). *Singularities of type IV*. They occur when Δ_2 has a cusp and the corresponding point on the surface M_2 lies on the crease. From the above parametrization Δ_2 , we deduce that it has a cusp if

$$\mu = 3(a - \epsilon_2)z + 6\epsilon_1 z^2 + 10bz^3$$

This cusp lies on the image of the crease when $y = 0$ in (\star) , that is

$$\lambda = \mu z - (3a - 2\epsilon_2)z^2 - 4\epsilon_1 z^3 - 5bz^4$$

Combining these two equations, singularities of type IV occur when:

$$(\lambda, \mu) = (-\epsilon_2 z^2 + 2\epsilon_1 z^3 + 5bz^4, 3(a - \epsilon_2)z + 6\epsilon_1 z^2 + 10bz^3)$$

This curve has a cusp at the origin when $a = \epsilon_2$. The cusp disappears as a moves from ϵ_2 .

(iii). *Singularities of type VIIa*. The crease has a cusp when

$$\lambda = -\frac{3}{4}a\mu^2 - \frac{\epsilon_1\epsilon_2}{2}\mu^3 - \frac{5}{16}b\mu^4$$

This is a curve in the (λ, μ) -parameter space which has an inflexion at the origin when $a = 0$. (Figure 1.4.9.)

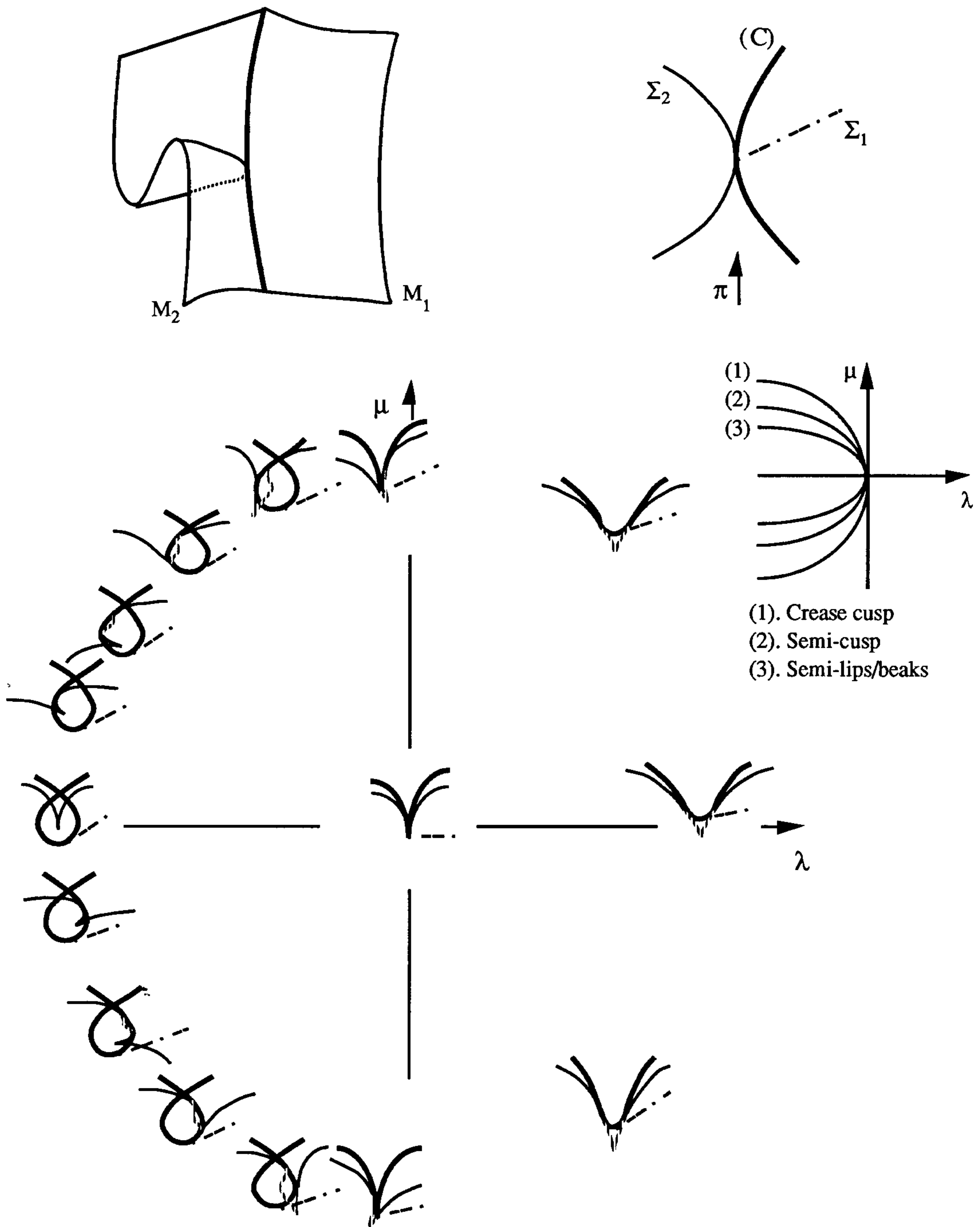

Figure 1.4.9. Double cusp, $a = 0.3$

The rest of the cases in Table 1 are special. They are realized as a family of projections of a family of piecewise-smooth surfaces. At the origin the surfaces have a common tangent plane. Note that generically two surfaces in R^3 will intersect transversally.

Case IX Non-transverse semi-fold

An $X\mathcal{A}$ -unfolding is $(ax^2 + by^2 + \epsilon_1xy + xz + \epsilon_2yz + cx^2z + dxyz + \lambda y, z)$. It can be realized as an orthogonal projection of the following 1-parameter family of piecewise-smooth surfaces

$$i(x, y, z, \lambda) = (ax^2 + by^2 + \epsilon_1xy + xz + \epsilon_2yz + cx^2z + dxyz + \lambda y, z, x + 2y)$$

When $\lambda = 0$, the two surfaces $M_1 = i(X_1)$ and $M_2 = i(X_2)$ have a common tangent plane at the origin.

The image of the crease is $\{(0, z)\}$, $\Delta_1 = \{(\frac{-ax^2}{1+2cx}, \frac{-2ax}{1+2cx})\}$ and $\Delta_2 = \{-by^2, -2by - \lambda\}$. When $\lambda = 0$ the image of the crease and the folds are tangential. As λ moves from the origin, the surface M_2 'moves' along the crease and the two surfaces M_1 and M_2 become transverse. The profile Δ_2 is translated along the image of the crease (figure 1.4.10).

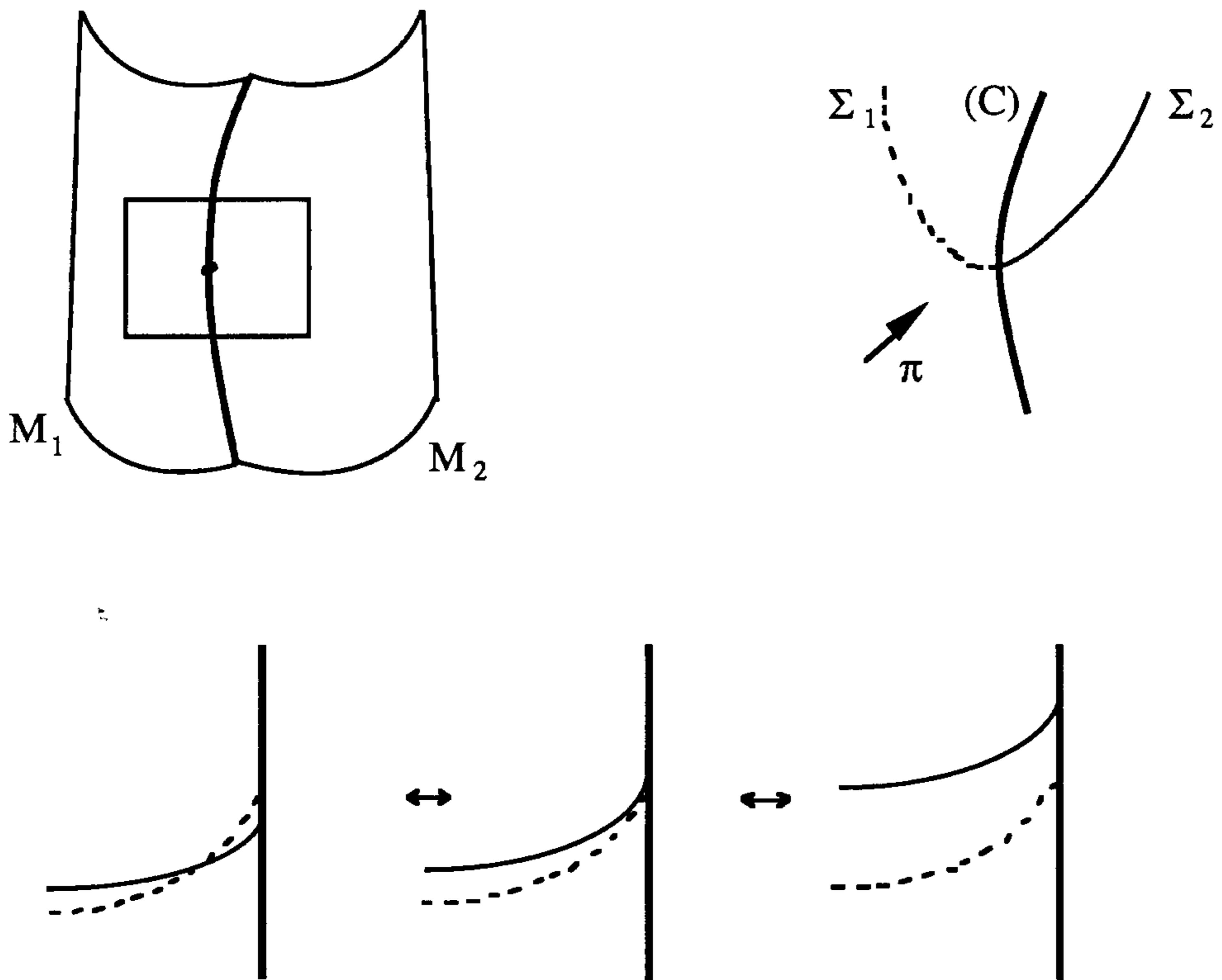

Figure 1.4.10. Non-transverse semi-fold

Case X Non-transverse semi-lips/beaks

An $X\mathcal{A}$ -unfolding is $(ax^2 + \epsilon_1y^2 + \epsilon_2xy + xz + \epsilon_3yz^2 + \lambda x + \mu y, z)$. This unfolding can be realized as a 1-parameter family of projections of 1-parameter family of piecewise-smooth surfaces. The 1-parameter family of the piecewise-smooth surfaces

is given by

$$i(x, y, z, \lambda) = (ax^2 + \epsilon_1 y^2 + \epsilon_2 xy + xz + \epsilon_3 yz^2 + \lambda x, z, x + y)$$

When $\lambda = \mu = 0$, the two surfaces have a common tangent plane at the origin. The direction of projection is transverse to the crease and to Σ_1 and Σ_2 . The crease and Σ_2 have 2-point contact at the origin (they are tangential). The projection of the crease is $\{(0, z)\}$, the profile Δ_1 is parametrized by $x \mapsto (-ax^2, -2ax - \lambda)$ and Δ_2 is parametrized by $z \mapsto (\frac{-\epsilon_1}{4}(\mu + \epsilon_3 z^2)^2, z)$. The profile Δ_1 is translated along the image of the crease as the surface M_1 moves along the crease.

There is a curve in the (λ, μ) parameter space where for λ and μ fixed the germ has singularities of type IX. This happens when Δ_1 and Δ_2 are tangent to the image of the crease at the same point, that is when $\mu + \epsilon_3 \lambda^2 = 0$

There is also another special curve where singularities of type III.a occur. It happens when $\Sigma_2 = \{(0, -\frac{\epsilon_1}{2}(\mu + \epsilon_3 z^2), z)\}$ and the crease are tangential, that is $\dot{\mu} = 0$. See (figures 1.4.11 and 1.4.12).

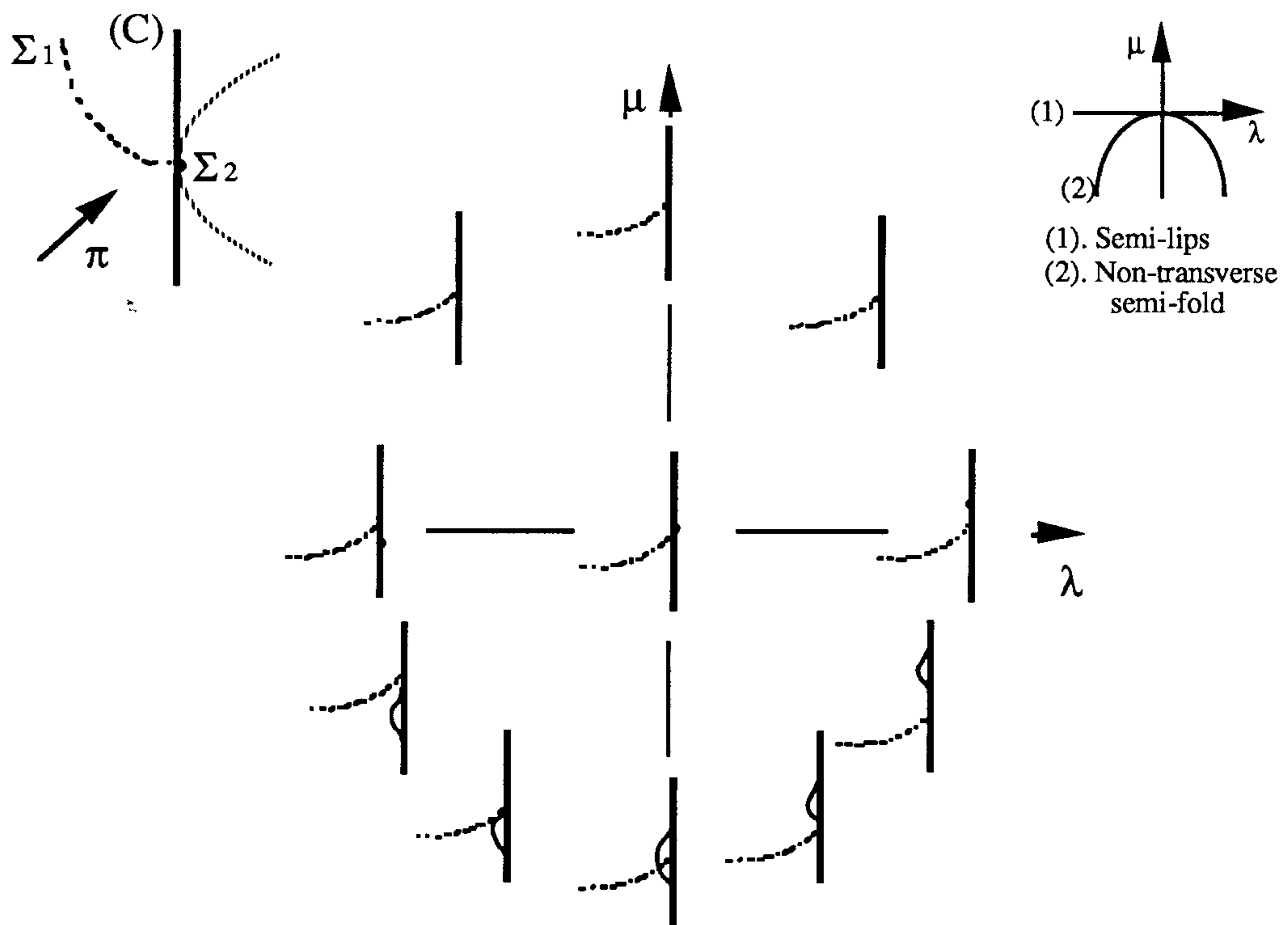

Figure 1.4.11. Non-transverse semi-lips

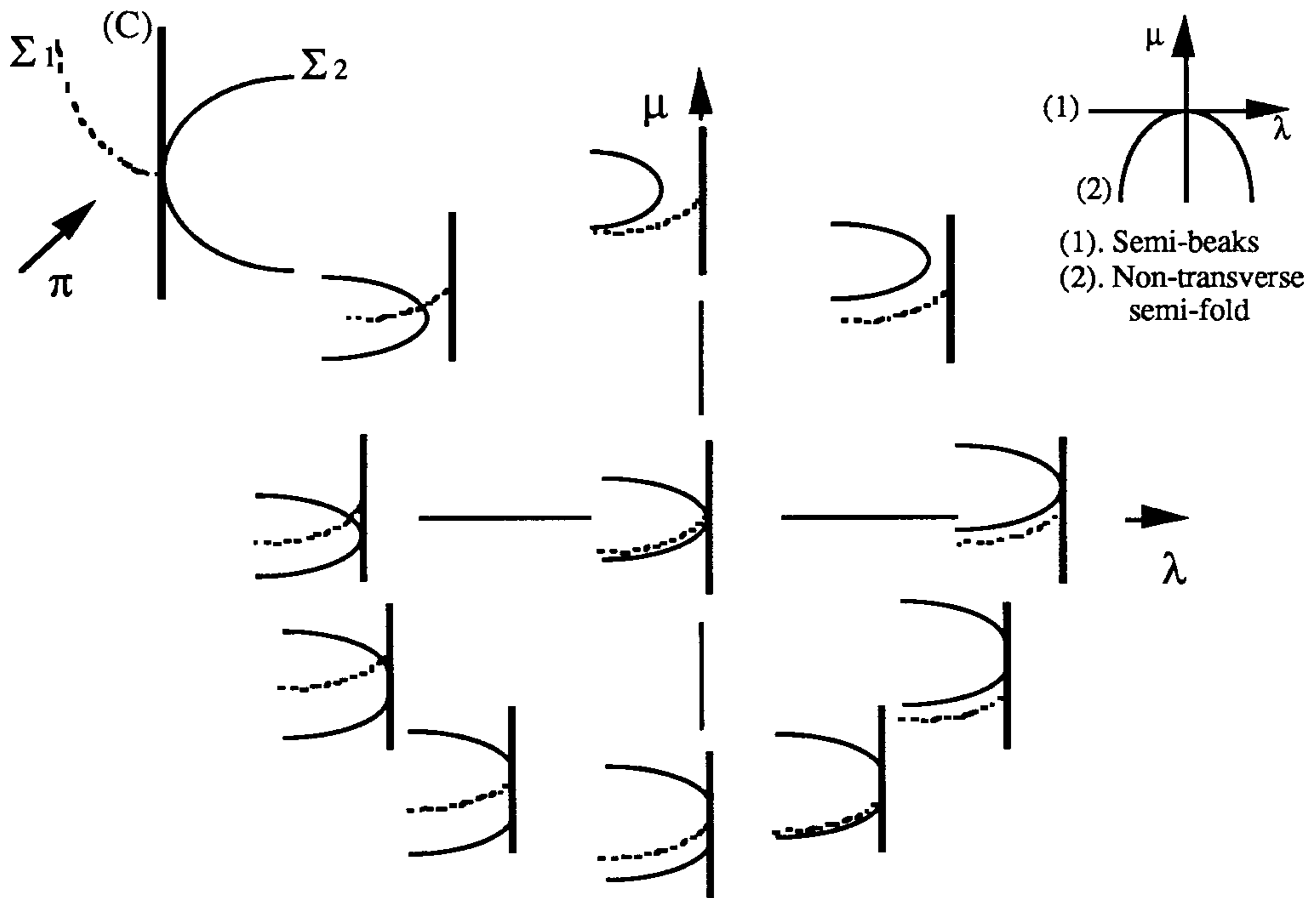

Figure 1.4.12. Non-transverse semi-beaks

Case XI Non-transverse semi-cusp

An $\chi\mathcal{A}$ -unfolding is $(ax^2 + \epsilon_1xy + xz + \epsilon_2yz + \epsilon_3y^3 + cy^4 + \lambda x + \mu y^2, z)$. The following unfolding $(ax^2 + \epsilon_1xy + xz + \epsilon_2yz + \epsilon_3y^3 + cy^4 + 2\lambda x + \mu(y + y^2), z)$ can be realized as a 1-parameter family of orthogonal projections of 1-parameter family of piecewise-smooth surfaces. The 1-parameter family of piecewise-smooth surfaces is given by

$$i(x, y, z, \lambda) = (ax^2 + \epsilon_1xy + xz + \epsilon_2yz + \epsilon_3y^3 + cy^4 + \lambda x, z, 2x + y + y^2)$$

When $\lambda = \mu = 0$, the two surfaces have a common tangent plane. The direction of projection $(0,0,1)$ is an asymptotic direction on M_2 at the origin. The profile Δ_2 has an ordinary cusp.

In the first given unfolding, the image of the crease is $\{(0, z)\}$, the profile Δ_2 is parametrized by $x \mapsto (-ax^2, -2ax - \lambda)$ and Δ_2 is parametrized by $y \mapsto (-\mu y^2 - 2\epsilon_3y^3 - 3by^4, -\epsilon_2(2\mu y + 3\epsilon_3y^2 + 4by^3))$

Singularities of type IX occur on the μ -axis and on the λ -axis singularities of type IV occur (figure 1.4.13).

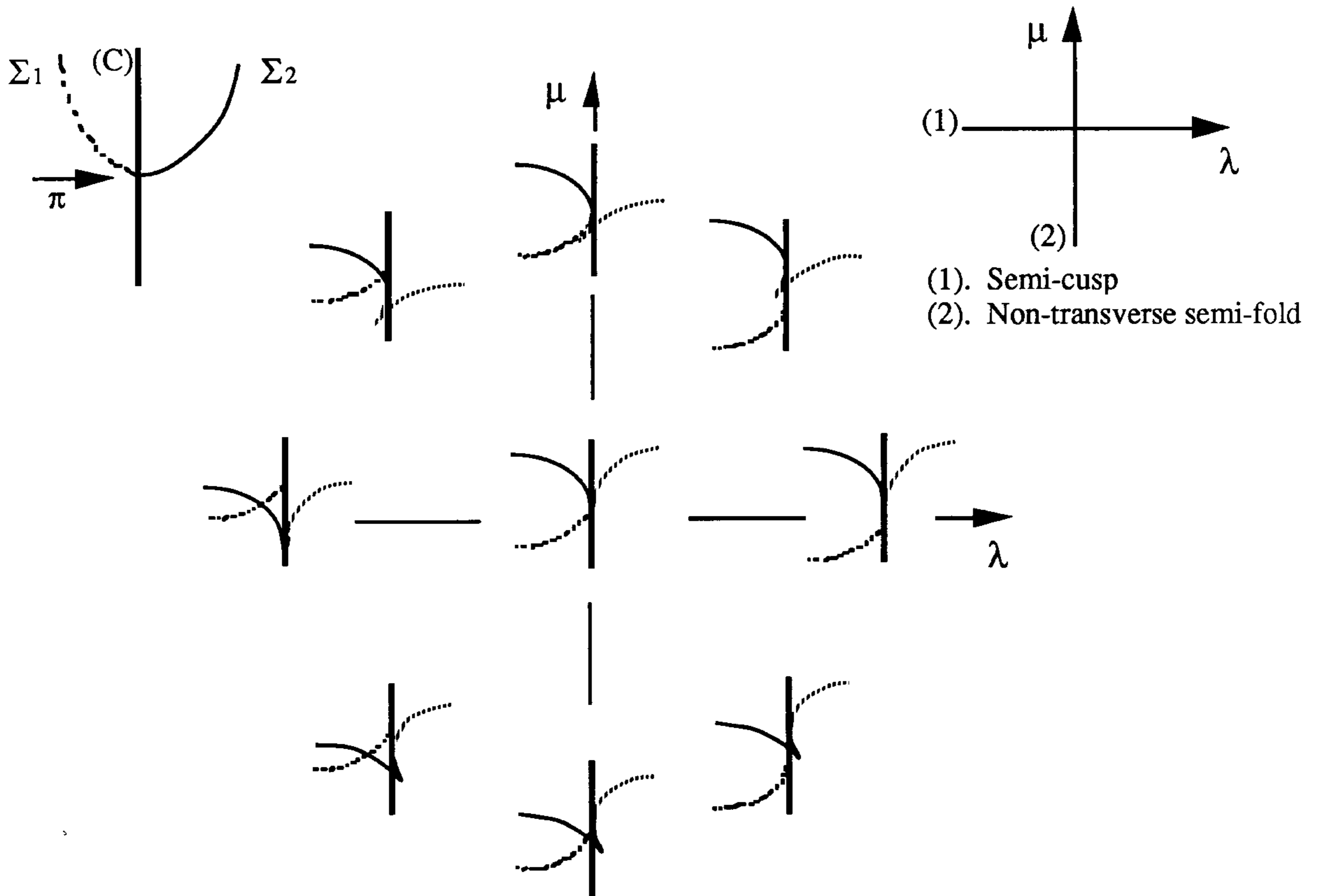

Figure 1.4.13. Non-transverse semi-cusp

Case XII Non-transverse crease-cusp

An $\mathcal{X}\mathcal{A}$ -unfolding is $(x + \epsilon_1 y + \epsilon_2 z^2, x^2 + axy + \epsilon_3 z^2 + bx^2 y + cz^3 + \lambda y + \mu z)$. This unfolding can be realized as a 1-parameter family of orthogonal projections of 1-parameter family of piecewise-smooth surfaces. The family of piecewise-smooth surfaces is given by

$$i(x, y, z, \lambda) = (x + \epsilon_1 y + \epsilon_2 z^2, x^2 + axy + \epsilon_3 z^2 + bx^2 y + cz^3 + \lambda y, y + z)$$

When $\lambda = \mu = 0$, the two surfaces have a common tangent plane. The direction of projection $(0,0,1)$ is tangent to the crease, the image of the crease has an ordinary cusp.

Singularities of type IX occur on the μ -axis and singularities of type VII.a occur on the λ -axis (figure 1.4.14).

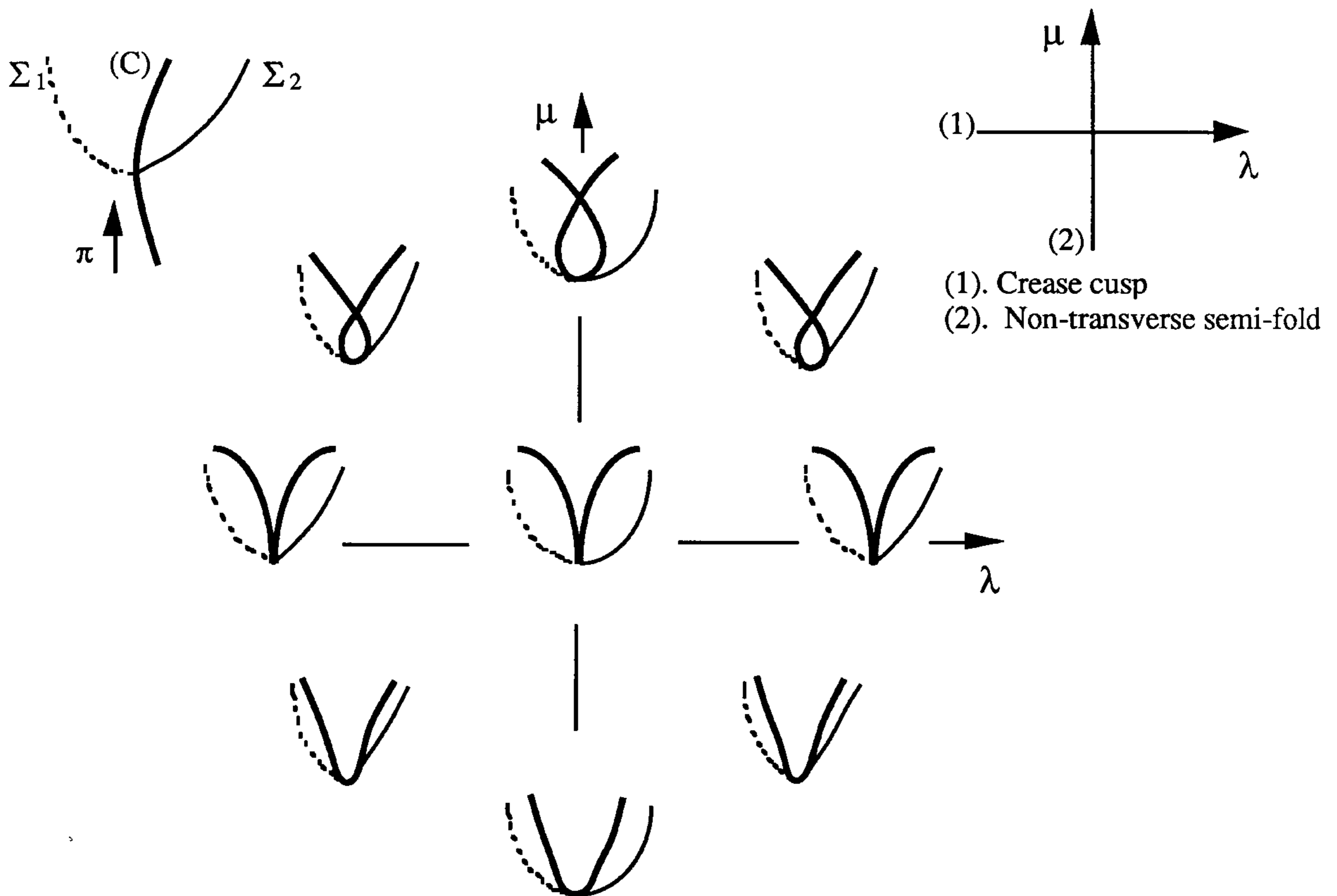

Figure 1.4.14. Non-transverse crease cusp

§5. The moduli and the topological versality

The cases VI, VIII- XII in Table 1 appear as families of non- $\chi\mathcal{A}$ -equivalent germs. The bifurcation diagram of a germ in the family does not seem to vary when taking those of nearby germs in the family. We weaken the equivalence relation and consider homeomorphic changes of coordinates, and hope that each of the above families of germs will fall locally into a single topological orbit. We shall apply James Damon's results on topological triviality and versality [D1], [D2], [D3], [D4] to prove that not only the germs are topologically trivial but their unfoldings are topologically versal. But first a summary of Damon's results.

Let $f_0: R^n, 0 \rightarrow R^p, 0$ (or from $C^n, 0$ to $C^p, 0$) be a smooth map germ and $f: R^{n+q}, 0 \rightarrow R^{p+q}, 0$ an unfolding of f_0 . If x, y, u denote the coordinates in R^n, R^p, R^q , then $f(x, u) = (\bar{f}(x, u), u)$. An unfolding is topologically trivial if there are germs of homeomorphisms $\phi: R^{n+q}, 0 \rightarrow R^{n+q}, 0$ and $\psi: R^{p+q}, 0 \rightarrow R^{p+q}, 0$ with $\phi(x, u) = (\bar{\phi}(x, u), u)$ and $\psi(y, u) = (\bar{\psi}(y, u), u)$ such that the following diagram commutes:

$$\begin{array}{ccc}
R^{n+q}, 0 & \xrightarrow{f} & R^{p+q}, 0 \\
\downarrow \phi & & \downarrow \psi \\
R^{n+q}, 0 & \xrightarrow{f_0 \times \text{id}} & R^{p+q}
\end{array}$$

An unfolding f is topologically versal if any unfolding of f is topologically trivial (Definition 9.3 in [D3]).

Let f be a 1-parameter unfolding ($q = 1$) of f_0 . (For $q > 1$ the equation is solved inductively.) To find diffeomorphisms ϕ and ψ which makes the above diagram commute, it is sufficient to solve the infinitesimal equation

$$\frac{\partial \bar{f}}{\partial u} = \xi \circ f - \zeta(f) \quad (*)$$

where ξ and ζ are smooth vector fields on R^n and R^p respectively. For topological triviality, it is enough to solve the localized form of the equation (*), that is

$$\rho \cdot \frac{\partial \bar{f}}{\partial u} = \xi \circ f - \zeta(f) \quad (**)$$

where $\rho: R^{n+1}, 0 \rightarrow R^+, 0$ is a smooth positive function which satisfies $\rho^{-1}(0) = 0 \times R$ [D1]. In this case ξ and ζ need not to be smooth but only locally integrable vector fields. In fact in [D3] Damon considered stratified vector fields (tangent to the graph of f). The integrability of such vector fields is ensured by Proposition 2.2 in [D3]. For geometric subgroups of \mathcal{A} and \mathcal{K} , the stratifications on R^{n+q} and R^{p+q} are constructed using systems of DA-algebras. For example, for the action of \mathcal{A} the system of DA-algebras on R^{n+q} is given by $\{C_{y,u} \xrightarrow{f^*} C_{x,u}\}$. We consider the sets $V_0 = R^{n+q}$, $V_1 = V(m_x \cdot C_{x,u}) = 0 \times R^q$, $V_2 = V(m_y \cdot C_{x,u}) = f^{-1}(0 \times R^q)$. The germ f is required to satisfy the stratification condition, that is f is a submersion on $f^{-1}(0 \times R^q) \setminus 0 \times R^q$. The stratification on R^{n+q} is then given by

$$\{0 \times R^q, f^{-1}(0 \times R^q) \setminus 0 \times R^q, R^{n+q} \setminus f^{-1}(0 \times R^q)\}$$

On R^{p+q} , the stratification is given by $\{0 \times R^q, R^{p+q} \setminus 0 \times R^q\}$.

The control functions of the convex filtrations on the system of DA-algebras induce the control functions of the stratified vector fields and provide algebraic lemmas for solving the equation (**) (§7 in [D3]).

When the germ f_0 is weighted homogeneous or semi-weighted homogeneous, weight filtration can be used on the system of DA-algebras. If an unfolding f of f_0 satisfies the stratification condition and is of finite codimension as an unfolding, the equation (**) can be solved. The unfolding f is then topologically versal (Theorem 9.10 in [D3]).

In practice, Theorem 4 in [D4] provides a sufficient condition for an unfolding to be topologically versal and a powerful tool to simplify the calculations. We introduce the necessary notation to state the theorem.

We assign weights $wt(x_i) = a_i$ and $wt(y_j) = d_j$ to the coordinates x and y in R^n and R^p respectively. The weight of a monomial is $wt(x^\alpha) = \sum a_i \alpha_i$ with $\alpha = (\alpha_1, \dots, \alpha_n)$. A polynomial is said to be weighted homogeneous if all its monomials have the same weight. A polynomial map $R^n \rightarrow R^p$ is weighted homogeneous if its components are weighted homogeneous.

If a function $g: R^n \rightarrow R$ is not weighted homogeneous, we say that $wt(g) \geq d$ if all monomials in the Taylor expansion of g have weight $\geq d$. If d_0 is the smallest integer that satisfies this property, then the *initial part* of g is $in(g) = \sum c_\alpha x^\alpha$ with $wt(x^\alpha) = d_0$. A germ $f: R^n \rightarrow R^p$ is *semi-weighted homogeneous* if the germ $(in(f_1), \dots, in(f_p))$ is of finite codimension (in our case of $X\mathcal{A}$ -finite codimension).

We also assign weights to vector fields as follows: $wt(\frac{\partial}{\partial x_i}) = -wt(x_i)$ and $wt(\frac{\partial}{\partial y_j}) = -wt(y_j)$. When f_0 is weighted homogeneous or semi-weighted homogeneous, the differential of the orbit map $d\alpha_{f_0}$ preserves weights. We can then define a weighting structure on the normal space $N(f_0) = V(f_0)/T\mathcal{A}_e.f_0$. We denote by $N(f_0)_m$ the terms in $N(f_0)$ of weight m (that is the images of terms of weight m in $V(f_0)$ by the projection map $V(f_0) \rightarrow N(f_0)$), and by $N(f_0)_{<m}$ the terms of weight $< m$. An unfolding $f = f_0 + \sum u_i \phi_i$ is said to be versal in weight m if $\{\phi_i\}$ is a basis for $N(f_0)_{<m}$. If $m = 0$, f is said to be negative versal.

Let $f = f_0 + \sum u_i \phi_i + \sum u_i \bar{\phi}_i$ be a versal unfolding of f_0 with $wt(\phi_i) \leq wt(f_0)$ and $wt(\bar{\phi}_i) > wt(f_0)$. Denote by $f_+ = f_0 + \sum_1^{p_+} u_i \phi_i$ the negative versal unfolding, and by u_+ the unfolding parameters (u_1, \dots, u_{p_+}) . The Euler vector field is

$$e = \sum wt(x_i) x_i \frac{\partial}{\partial x_i} - \sum wt(y_j) y_j \frac{\partial}{\partial y_j}$$

and the Euler relation for f_+ is the vector

$$e(f_+) = \sum wt(x_i) x_i \frac{\partial f_+}{\partial x_i} - \sum wt(y_j) (y_j \circ f_+) \frac{\partial}{\partial y_j}$$

(The vector $e(f_+)$ is in the tangent space $T_X \mathcal{A}_{u_+, e}.f_+$.) Let g_i be an element in C_x of weight l_i . Then there exist weighted homogeneous germs h_{ij} in C_{u_+} of weight $l_i - wt(\bar{\phi}_j)$ such that

$$g_i.e(f_+) = \sum h_{ij} \bar{\phi}_j \text{ modulo } C_{u_+} \cdot \{\phi_i\} + T_X \mathcal{A}_{u_+, e}.f_+$$

1.5.1. Theorem : (Theorem 4 in [D4]). Suppose f_+ satisfies the stratification condition and there exists $g_1, \dots, g_r \in R_0$ such that the $r \times r$ minors of (h_{ij}) generate an ideal of finite codimension in C_{u_+} . Then f_+ is \mathcal{G} -topologically versal.

We first remark that the germs considered here are germs of submersions (for cases VI and VIII) or have an isolated singularity at the origin (for the case IX). Hence the stratification condition is trivially satisfied.

At this point I am very much indebted to James Damon for pointing out that the germ VI is semi-weighted homogeneous, and for showing that its unfolding of negative weight is topologically versal.

1.5.2. Proposition : (*James Damon*). *The unfolding $(\epsilon x + yz^2 + y^2z + ay^3 + \lambda y + \mu y^2, z)$ is topologically versal provided $a \neq 0, \frac{1}{3}, \frac{1}{4}$.*

Proof : The germ $f_0 = (\epsilon x + yz^2 + y^2z + ay^3, z)$ is weighted homogeneous for the weights $wt(x) = 3, wt(y) = 1, wt(z) = 1$. Calculations show that it is $4\text{-}X\mathcal{A}$ -determined provided $a \neq 0, \frac{1}{3}, \frac{1}{4}$. A versal unfolding of f_0 is $f(x, y, z, a, b, \lambda, \mu) = (\epsilon x + yz^2 + y^2z + ay^3 + by^3z + \lambda y + \mu y^2, z)$, and negative versal unfolding is $f_+(x, y, z, \lambda, \mu) = (\epsilon x + yz^2 + y^2z + ay^3 + \lambda y + \mu y^2, z)$. The Euler relation for f_+ is $e(f_+) = (2\lambda y + \mu y^2)$. We consider the vectors $z.e(f_+), z^2.e(f_+), z^3.e(f_+)$ modulo $T_{\lambda, \mu}X\mathcal{A}_e.f_+ + C_{\lambda, \mu}\{(y, 0), (y^2, 0)\} + m_{\lambda, \mu}^2V(f_+)$. We have

$$z.e(f_+) \equiv (-a\mu y^3, 0)$$

$$z^2.e(f_+) \equiv (a\lambda y^3 - a\mu y^3 z, 0)$$

The determinant of the coordinates of the above vectors with respect to the basis $\{(y^3, 0), (y^3 z, 0)\}$ is $-a\mu^2$. It is null if and only if $\mu = 0$. Now we can work modulo m_μ .

$$z^2.e(f_+) \equiv (a\lambda y^3, 0)$$

$$z^3.e(f_+) \equiv (-a\lambda y^3 z, 0)$$

The determinant of the coordinates of the above vectors with respect to the basis $\{(y^3, 0), (y^3 z, 0)\}$ is $-a\lambda^2$. It is null if and only if $\mu = 0$. Hence the matrix of the coordinates of the vectors $z.e(f_+), z^2.e(f_+), z^3.e(f_+)$ is of rank less than 2 if and only if $\lambda = \mu = 0$. The unfolding f_+ is then topologically versal by Theorem 1.5.1. \square

1.5.3. Remark : The exceptional values $0, \frac{1}{3}, \frac{1}{4}$ of the modulus a can be explained geometrically by looking at the critical set and the critical locus of the germ f_0 .

When $a = \frac{1}{3}$, the critical set changes from a crossing ($a < \frac{1}{3}$) to an isolated point ($a > \frac{1}{3}$), and the critical locus changes from “beaks” to “lips”.

When $a = \frac{1}{4}$, the critical locus of the germ f_0 consists of a triple line, the two branches of the profile collapse on the image of the crease. (For the germ $f =$

$(\epsilon x + yz^2 + y^2z + ay^3 + \epsilon_1 y^4, z)$ the two branches of the profile have higher contact with the crease.)

When $a = 0$, the viewing direction (the kernel of f_0) is tangent to one of the branches of Σ_2 . Its image has an ordinary cusp at the origin. In (figure 1.5.1) we draw the critical locus of f_0 for different values of a .

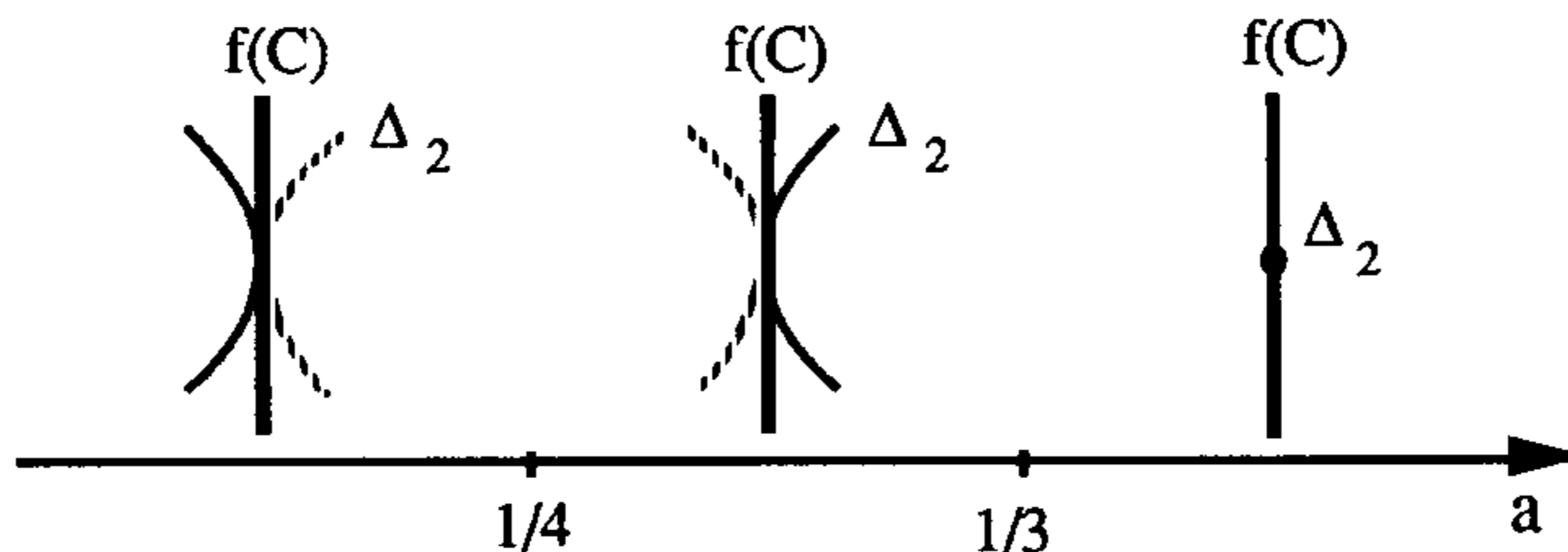

Figure 1.5.1.

1.5.4. Proposition : *The unfolding $(x + yz + az^3 + \lambda z, y + \epsilon_2 z^2 + \mu z)$ is topologically versal if $a \neq 0, \epsilon_2, -\frac{1}{3}\epsilon_2, \frac{2}{3}\epsilon_2, \frac{3}{2}\epsilon_2, \frac{4}{3}\epsilon_2$.*

Proof: The germ $f_0 = (x + yz + a_0 z^3, y + \epsilon_2 z^2)$ is weighted homogeneous for the weights $wt(x) = 3, wt(y) = 2, wt(z) = 1$. Calculations show that it is 7 - $\mathcal{X}\mathcal{A}$ -determined provided $a \neq 0, \epsilon_2, -\frac{1}{3}\epsilon_2, \frac{2}{3}\epsilon_2$. A versal unfolding is $f(x, y, z, a, b, c, d, \lambda, \mu) = (x + yz + az^3 + bz^4 + cz^5 + dz^7 + \lambda z, y + \epsilon_2 z^2 + \mu z)$. The unfolding $f_+ = (x + yz + a_0 z^3 + \lambda z, y + \epsilon_2 z^2 + \mu z)$ is of negative versal. The Euler relation for f_+ is $e(f_+) = -(2\lambda z, \mu z)$. If we consider the following vectors modulo $T_{\lambda, \mu} \mathcal{X} \mathcal{A}_e \cdot f_+ + C_{\lambda, \mu} \{(z, 0), (0, z)\} + m_{\lambda, \mu}^2 V(f_+)$

$$y \cdot e(f_+) \equiv \left(-a_0 \lambda z^3 - \frac{1}{3a_0 - 4\epsilon_2} \mu z^4, 0 \right),$$

$$y^2 \cdot e(f_+) \equiv \left(\frac{a_0(2\epsilon_2 - 3a_0)}{3 - 2a_0\epsilon_2} \mu z^5, 0 \right),$$

$$z^3 \cdot e(f_+) \equiv \left(2\lambda z^4 + \frac{a_0(4\epsilon_2 - 3a_0)}{3 - 2a_0\epsilon_2} \mu z^5, 0 \right),$$

the minors of the matrix of their coefficients with respect to the basis $\{(z^3, 0), (z^4, 0), (z^5, 0)\}$, generate an ideal of finite codimension in $C_{\lambda, \mu}$ provided $a_0 \neq 0, \frac{2}{3}\epsilon_2, \frac{3}{2}\epsilon_2, \frac{4}{3}\epsilon_2$. Therefore, by Theorem 1.5.1, the unfolding f_+ is topologically versal for a different from all the exceptional values mentioned above. \square

1.5.5. Remark : In (figure 1.5.2) we draw the critical locus of the germ f_0 for some values of the modulus a .

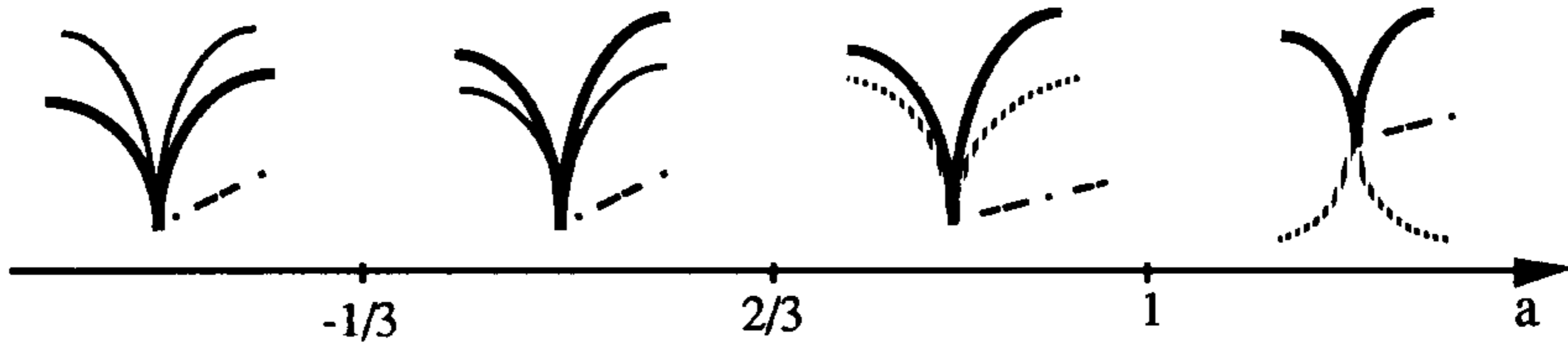

Figure 1.5.2.

1.5.6. Proposition : *The unfolding $(ax^2 + by^2 + \epsilon_1xy + xz + \epsilon_2yz + \lambda y, z)$ is topologically versal if $a \neq 0, b \neq 0, a - b \neq 0, 4ab - 1 \neq 0$.*

Proof: The germ $f_0 = (ax^2 + by^2 + \epsilon_1xy + xz + \epsilon_2yz + \lambda y, z)$ is weighted homogeneous for the weights $wt(x) = wt(y) = wt(z) = 1$. Calculations show that it is $4\text{-}\mathcal{X}\mathcal{A}$ -determined provided $a \neq 0, b \neq 0, a - b \neq 0, 4ab - 1 \neq 0$. A versal unfolding is $f(x, y, x, a, b, c, d, \lambda) = (ax^2 + by^2 + \epsilon_1xy + xz + \epsilon_2yz + cx^2z + dxyz + \lambda y, z)$. The unfolding $f_+(x, y, x, \lambda) = (ax^2 + by^2 + \epsilon_1xy + xz + \epsilon_2yz + \lambda y, 0)$ is negative versal. The Euler relation for f_+ is $e(f_+) = -(\lambda y, 0)$. The coefficient of the vector $(y^2, 0)$ in $y \cdot e(f_+) = -(\lambda y^2, 0)$ generates an ideal of finite codimension in C_λ . Therefore, by Theorem 1.5.1, the unfolding f_+ is topologically versal for $a \neq 0, b \neq 0, a - b \neq 0, 4ab - 1 \neq 0$. \square

1.5.7. Remark : When $a = 0$ (or $b = 0$), the profile Δ_1 (or Δ_2) is a single point. When $a = b$ the profiles (of the germ f_0) coincide. I do not know of an explanation of the case $4ab - 1 = 0$.

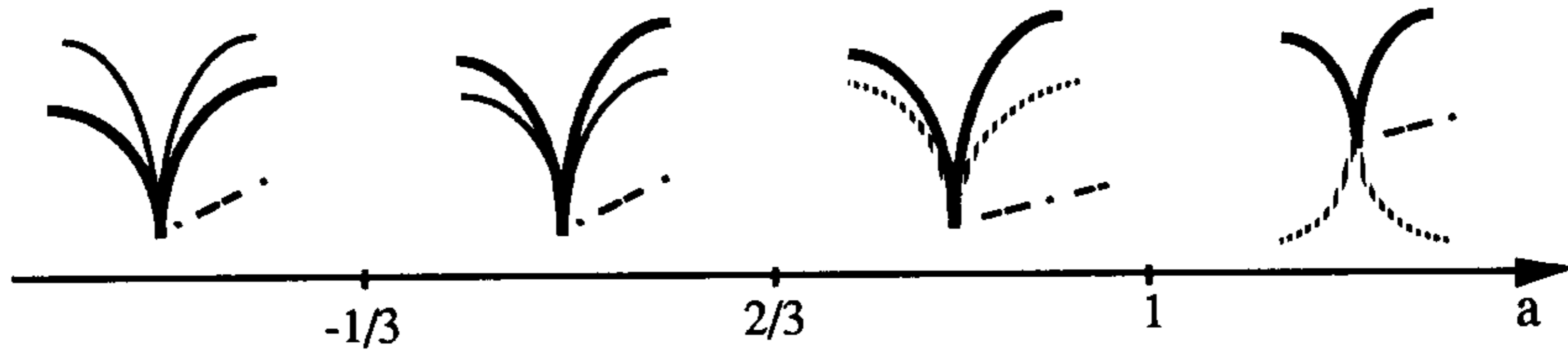

Figure 1.5.2.

1.5.6. Proposition : *The unfolding $(ax^2 + by^2 + \epsilon_1xy + xz + \epsilon_2yz + \lambda y, z)$ is topologically versal if $a \neq 0, b \neq 0, a - b \neq 0, 4ab - 1 \neq 0$.*

Proof: The germ $f_0 = (ax^2 + by^2 + \epsilon_1xy + xz + \epsilon_2yz + \lambda y, z)$ is weighted homogeneous for the weights $wt(x) = wt(y) = wt(z) = 1$. Calculations show that it is $4\text{-}_X\mathcal{A}$ -determined provided $a \neq 0, b \neq 0, a - b \neq 0, 4ab - 1 \neq 0$. A versal unfolding is $f(x, y, x, a, b, c, d, \lambda) = (ax^2 + by^2 + \epsilon_1xy + xz + \epsilon_2yz + cx^2z + dxyz + \lambda y, z)$. The unfolding $f_+(x, y, x, \lambda) = (ax^2 + by^2 + \epsilon_1xy + xz + \epsilon_2yz + \lambda y, 0)$ is negative versal. The Euler relation for f_+ is $e(f_+) = -(\lambda y, 0)$. The coefficient of the vector $(y^2, 0)$ in $y \cdot e(f_+) = -(\lambda y^2, 0)$ generates an ideal of finite codimension in C_λ . Therefore, by Theorem 1.5.1, the unfolding f_+ is topologically versal for $a \neq 0, b \neq 0, a - b \neq 0, 4ab - 1 \neq 0$. \square

1.5.7. Remark : When $a = 0$ (or $b = 0$), the profile Δ_1 (or Δ_2) is a single point. When $a = b$ the profiles (of the germ f_0) coincide. I do not know of an explanation of the case $4ab - 1 = 0$.

Projections of triples of surfaces

§1. Introduction

In Chapter 1 we classified projections of piecewise-smooth surfaces. In this chapter we extend the classification to orthogonal projections of triples of surfaces onto planes. Three smooth surfaces in the Euclidean space meet in general transversally in a corner. Each pair of surfaces intersect on a smooth crease and the resulting three creases form the corner. For a given triple of surfaces and an orthogonal projection, one actually sees the projection of the corner together with the apparent contours of the three surfaces. We want to describe what we see when the direction of projection changes along a line or in a plane.

We shall take for a local model of three surfaces meeting transversally in a corner the germ of $Y = Y_1 \cup Y_2 \cup Y_3$ with $Y_1 = \{(x, y, 0), x \geq 0, y \geq 0\}$, $Y_2 = \{(0, y, z), y \geq 0, z \geq 0\}$, and $Y_3 = \{(x, 0, z), x \geq 0, z \geq 0\}$. Any germ of a triple of surfaces is the image of Y by a germ of a diffeomorphism in R^3 . An orthogonal projection of such an object onto a plane can be represented by a germ of a submersion $f : R^3, 0 \rightarrow R^2, 0$ (figure 2.1.1).

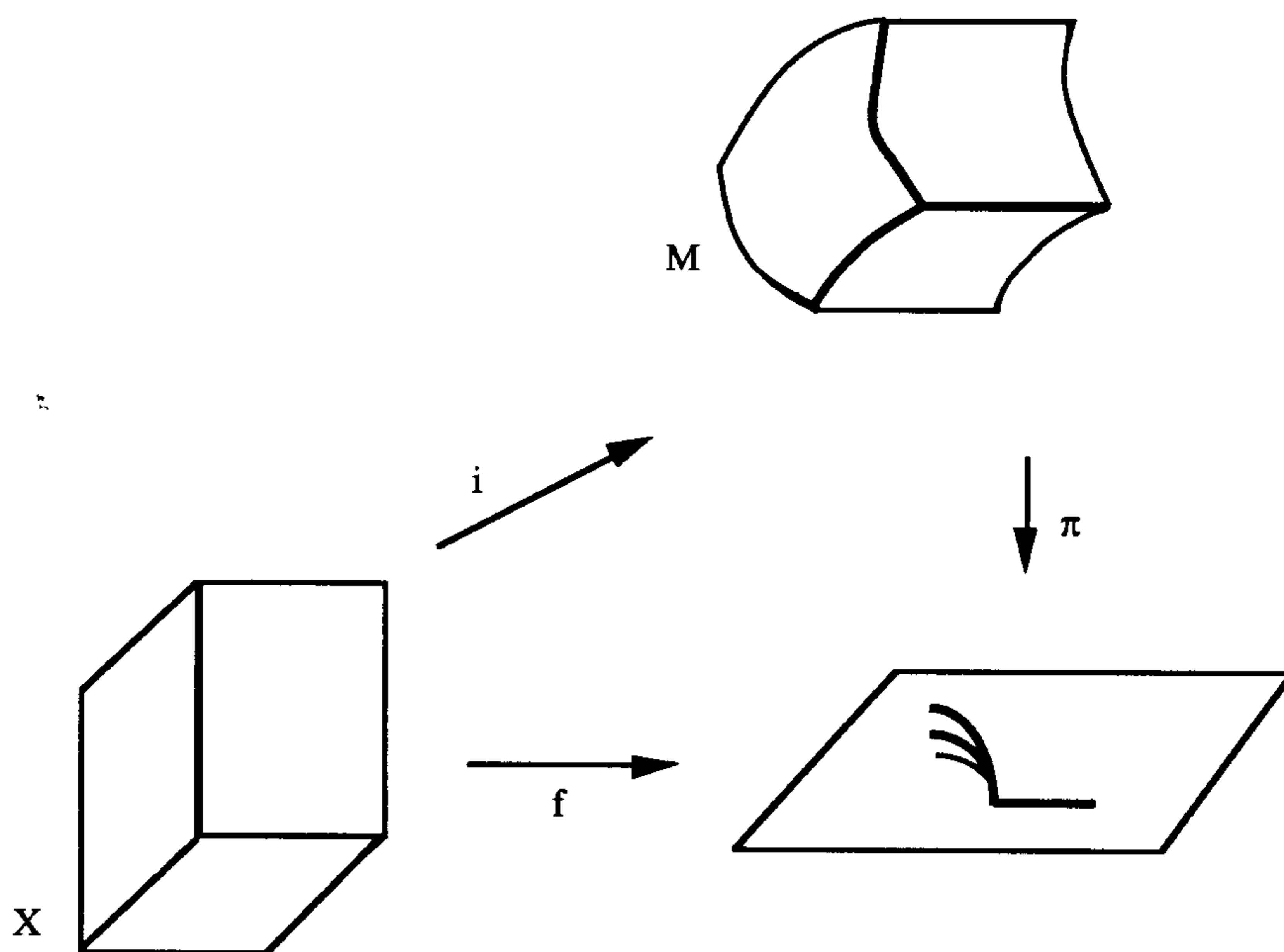

Figure 2.1.1. Projection of a triple of surfaces

We classify germs of submersions $R^3, 0 \rightarrow R^2, 0$ up to smooth origin preserving changes of coordinates in the source which preserve Y , and smooth origin preserving changes of coordinates in the target. This yields an action of a subgroup $\gamma\mathcal{A}$ of the

Mather group \mathcal{A} on $C_3^{\times 2}$. The group $\gamma\mathcal{A}$ preserves the variety Y in the source, it is a special geometric subgroup of \mathcal{A} in Damon's terminology [D3]. The calculations are summarized in the following theorem where we give the list of the orbits of codimension less than 2 of the action of $\gamma\mathcal{A}$, allowing the codimension to be bigger in the presence of moduli.

2.1.1. Theorem : *The orbits of germs of submersions of the action of $\gamma\mathcal{A}$ on $C_3^{\times 2}$ of codimension less than 2 are shown in Table 2.*

Table 2 ($\epsilon_i = \pm 1$)

Normal forms	Names	$\gamma\mathcal{A}$ -codimension
I. $(x + \epsilon_1 z, y + \epsilon_2 z)$	Stable corner	0
II. $(x + \epsilon_1 y, z + \epsilon_2 xy + ax^2 + \epsilon_3 x^3)$	C- semi-fold	2
III. $(x + \epsilon_1 y, z + \epsilon_2 xy + \epsilon_1 \epsilon_2 x^2 + \epsilon_3 x^3 + ay^4)$	C- semi-cusp	3
IV. $(x + \epsilon_1 y, z + \epsilon_2 x^2 + \epsilon_3 y^k)$	$k = 3$ C-semi-lips/beaks	$k - 1$
V. $(x + \epsilon_1 yz + \epsilon_2 z^2, y + \epsilon_3 xz + az^2 + bz^3)$	C- crease cusp	4

The classification is carried out inductively on the jet level. The method used here is identical to that in Chapter 1. We give in section 2 a brief summary of the changes needed for the action of the group $\gamma\mathcal{A}$ and the expression for the tangent space to the orbit of a germ. In section 3 we carry out the classification on the jet level until a sufficient jet is found. We omit some of the proofs of determinacy of germs since it is just a matter of messy calculations. The geometry of each normal form in Table 2 is given in the last section.

§2. Classification method

We use the same notation as in Chapter 1. The main changes here are those on the expression for the tangent space to an orbit and the adaptation of Theorem 1.9 and Corollary 2.5.2 in [B-dP-W] to the action of $\gamma\mathcal{A}$.

The expression for $T_{\gamma\mathcal{A}.f}$

Let $\xi \in V(Y)$. We can write $\xi(x, y, z) = \xi_1(x, y, z)\partial_x + \xi_2(x, y, z)\partial_y + \xi_3(x, y, z)\partial_z$ as a representative of ξ at the origin. Since ξ is tangent to Y , $\xi_1(x, 0, z) =$

$\xi_2(0, y, z) = \xi_3(x, y, 0) = 0$. It follows by Hadamard's lemma that $\xi_1(x, y, z) = x\tilde{\xi}_1(x, y, z)$, $\xi_2(x, y, z) = y\tilde{\xi}_2(x, y, z)$ and $\xi_3(x, y, z) = z\tilde{\xi}_3(x, y, z)$ for some $\tilde{\xi}_1$, $\tilde{\xi}_2$ and $\tilde{\xi}_3$ in C_3 . The set $V(Y)$ is then the C_3 -module generated by $\{x\partial_x, y\partial_y, z\partial_z\}$ and $tf(V(Y))$ is the C_3 -module generated by $\{x\frac{\partial f}{\partial x}, y\frac{\partial f}{\partial y}, z\frac{\partial f}{\partial z}\}$. Thus, $tf(V(Y) \cap m_3.V(R^3)) = C_3 \cdot \{x\frac{\partial f}{\partial x}, y\frac{\partial f}{\partial y}, z\frac{\partial f}{\partial z}\}$. The tangent space to the $\gamma\mathcal{A}$ -orbit of f at f is then

$$T_Y \mathcal{A}.f = C_3 \cdot \{x\frac{\partial f}{\partial x}, y\frac{\partial f}{\partial y}, z\frac{\partial f}{\partial z}\} + f^*m_2\{e_1, e_2\}$$

The pseudo tangent space is

$$T_Y \mathcal{A}_e.f = C_3 \cdot \{x\frac{\partial f}{\partial x}, y\frac{\partial f}{\partial y}, z\frac{\partial f}{\partial z}\} + f^*\{e_1, e_2\}$$

§3. The classification

The classification is carried out inductively on the jet level. For the determinacy calculations, we use mainly the adapted version of Theorem 1.9 and Corollary 2.5.2 in [B-dP-W]. We can replace in Theorem 1.2.2, Corollary 1.2.3 and Proposition 1.2.5 in Chapter 1, $x\mathcal{A}$ by $\gamma\mathcal{A}$ and the results still hold. We shall refer to these statements whenever needed.

A sufficient jet is given its corresponding number in Table 2. The $\gamma\mathcal{A}$ -equivalence relation on $J^k(3, 2)$ is denoted by \simeq . The coordinates in the source and target are denote by (x, y, z) and (u, v) respectively.

The 1-jet $f \overset{\sim}{=} (ax + by + cz, dx + ey + fz)$

(1) If $a \neq 0$ or $d \neq 0$. (We can assume that $a \neq 0$ otherwise we can make the change of coordinates $(u, v) \mapsto (v, u)$.) Linear change of coordinates $(u, v) \mapsto (u, v - \frac{d}{a}u)$ in the target yields

$$f \simeq (ax + by + cz, \frac{ae - bd}{a}y + \frac{af - cd}{a}z)$$

(i). If $ae - bd \neq 0$, then $f \simeq (ax + \frac{a(ce - bf)}{ae - bd}z, \frac{ae - bd}{a}y + \frac{af - cd}{a}z)$.

If $af - cd \neq 0$ and $ce - bf \neq 0$, then $f \simeq (x + \epsilon_1z, y + \epsilon_2z)$.

If $af - cd \neq 0$ and $ce - bf = 0$, then $f \simeq (x, y + \epsilon_1z)$.

If $af - cd = 0$ and $ce - bf \neq 0$, then $f \simeq (x + \epsilon_1z, y)$.

If $af - cd = 0$ and $ce - bf = 0$, then $f \simeq (x, y)$.

The case $ae - bd = 0, af - cd \neq 0$ give germs that could be considered equivalent to those above by interchanging the pieces of surfaces Y_i . The germs $(x, y + \epsilon_1 z)$ and $(x + \epsilon_1 z, y)$ can also be considered equivalent by interchanging the surfaces Y_i .

(ii). If $ae - bd = af - cd = 0$, then

$$\begin{aligned} f &\simeq (x + \epsilon_1 y + \epsilon_2 z, 0) && \text{if } b, c \neq 0 \\ f &\simeq (x + \epsilon y, 0) && \text{if } b \neq 0 \text{ and } c = 0 \\ f &\simeq (x + \epsilon z, 0) && \text{if } b = 0 \text{ and } c \neq 0 \\ f &\simeq (x, 0) && \text{if } b = c = 0 \end{aligned}$$

(2) If $a = d = 0$, then $f \simeq (by + cz, ey + fz)$. Using explicit linear changes of coordinates we obtain :

$$\begin{aligned} f &\simeq (y, z) && \text{if } bf - ce \neq 0 \\ f &\simeq (0, y + \epsilon z) && \text{if } bf - ce = 0 \text{ and } c \text{ and } b \neq 0 \text{ (or } e \text{ and } f \neq 0) \\ f &\simeq (0, z) && \text{if } b = e = 0 \text{ and } c \text{ or } f \neq 0 \\ f &\simeq (0, y) && \text{if } c = f = 0 \text{ and } b \text{ or } e \neq 0 \\ f &= (0, 0) && \text{if } b = c = e = f = 0 \end{aligned}$$

We are classifying germs of submersions, so the relevant 1-jets for our investigation are the following :

$$\begin{aligned} &(x + \epsilon_1 z, y + \epsilon_2 z) \\ &(x + \epsilon_1 y, z) \\ &(x, y). \end{aligned}$$

2.3.1. Proposition : *The germ $(x + \epsilon_1 z, y + \epsilon_2 z)$ is $Y\mathcal{A}$ -stable.*

Proof : It is easy to check that in this case $l = 1$ and $k = 1$ in Corollary 1.2.3. Therefore $f = (x + \epsilon_1 z, y + \epsilon_2 z)$ is 1- $Y\mathcal{A}$ -determined. We also have $T_{Y\mathcal{A}_e}.f = V(f)$, hence f is stable. \square

The 1-jet $(x + \epsilon_1 y, z)$

A complete 2-transversal is $R.\{(xy, 0), (x^2, 0)\}$. Any 2-jet with 1-jet $(x + \epsilon_1 y, z)$ is $Y\mathcal{A}$ -equivalent to $(x + \epsilon_1 y, z + ax^2 + bxy)$. The orbits in the 2-jet with 1-jet $(x + \epsilon_1 y, z)$ are

$$\begin{aligned} &(x + \epsilon_1 y, z + \epsilon_2 xy + ax^2) && \text{if } b \neq 0 \\ &(x + \epsilon_1 y, z + \epsilon_2 x^2) && \text{if } a \neq 0 \text{ and } b = 0 \\ &(x + \epsilon_1 y, z) && \text{if } a = b = 0 \end{aligned}$$

2.3.2. Proposition : (1). The germ $(x + \epsilon_1 y, z + \epsilon_2 xy + ax^2 + \epsilon_3 x^3)$ is $\mathfrak{3}\text{-}Y\mathcal{A}$ -determined if $a \neq \epsilon_1 \epsilon_2$. Its codimension is 2; this is the case II in Table 2.

(2). The germ $(x + \epsilon_1 y, z + \epsilon_2 xy + \epsilon_1 \epsilon_2 x^2 + \epsilon_3 x^3 + ay^4)$ is $\mathfrak{4}\text{-}Y\mathcal{A}$ -determined if $a \neq -\frac{3}{8}\epsilon_1 \epsilon_2$. Its codimension is 3; this is the case III in Table 2.

(3). The germ $(x + \epsilon_1 y, z + \epsilon_2 x^2 + \epsilon_3 y^k)$ is $k\text{-}Y\mathcal{A}$ -determined. It is of codimension $k - 1$; this is the case IV in Table 2.

Proof: (1). The complete 3-transversal of $f = (x + \epsilon_1 y, z + \epsilon_2 xy + ax^2)$ is $R.\{(x^3, 0)\}$, and the orbits in the 3-Jet with 2-jet as f are $(x + \epsilon_1 y, z + \epsilon_2 xy + ax^2 + \epsilon_3 x^3)$ and $(x + \epsilon_1 y, z + \epsilon_2 xy + ax^2)$.

The claim is that $(x + \epsilon_1 y, z + \epsilon_2 xy + ax^2 + \epsilon_3 x^3)$ is $\mathfrak{3}\text{-}Y\mathcal{A}$ -determined provided $a \neq \epsilon_1 \epsilon_2$, and $(x + \epsilon_1 y, z + \epsilon_2 xy + ax^2)$ is $\mathfrak{3}\text{-}Y\mathcal{A}$ -determined provided $a \neq 0, \frac{\epsilon_1 \epsilon_2}{2}, \epsilon_1 \epsilon_2$. Let $f = (x + \epsilon_1 y, z + \epsilon_2 xy + ax^2 + \epsilon_3 x^3)$. Then,

$$\begin{aligned} x \frac{\partial f}{\partial x} &= (x, \epsilon_2 xy + 2ax^2 + 3\epsilon_3 x^3) \\ y \frac{\partial f}{\partial y} &= (\epsilon_1 y, \epsilon_2 xy) \\ z \frac{\partial f}{\partial z} &= (0, z) \end{aligned}$$

It is not hard to show that $m_3^2.C_3^{\times 2} \subset C_3.\{x \frac{\partial f}{\partial x}, y \frac{\partial f}{\partial y}, z \frac{\partial f}{\partial z}\} + f^*m_2.C_2^{\times 2} + m_3^3.C_3^{\times 2}$ provided $a \neq \epsilon_1 \epsilon_2$. Thus $l = 2$ in Corollary 1.2.3.

We need to prove that $m_3^4.C_3^{\times 2} \subset T_Y\mathcal{A}_1.f + m_3^6.C_3^{\times 2}$. It is clear from the expressions of $x \frac{\partial f}{\partial x}, y \frac{\partial f}{\partial y}$ and $z \frac{\partial f}{\partial z}$ that it is enough to show that the monomials of degree 5 and 4 in $C_{x,y}\{(0, 1)\}$ are in $T_Y\mathcal{A}_1.f + m_3^6.C_3^{\times 2}$.

For the degree 5 calculations, we use the following vectors in $T_Y\mathcal{A}_1.f$ modulo $m_3^6.C_3^{\times 2}$.

$$(1) \quad x^3 y \left(\frac{\partial f}{\partial x} - \epsilon_1 \frac{\partial f}{\partial y} \right) = (0, \epsilon_2 x^3 y^2 + (2a - \epsilon_1 \epsilon_2) x^4 y)$$

$$(2) \quad x^2 y^2 \left(\frac{\partial f}{\partial x} - \epsilon_1 \frac{\partial f}{\partial y} \right) = (0, \epsilon_2 x^2 y^3 + (2a - \epsilon_1 \epsilon_2) x^3 y^2)$$

$$(3) \quad xy^3 \left(\frac{\partial f}{\partial x} - \epsilon_1 \frac{\partial f}{\partial y} \right) = (0, \epsilon_2 xy^4 + (2a - \epsilon_1 \epsilon_2) x^2 y^3)$$

$$(4) \quad x^4 \frac{\partial f}{\partial x} + (4x^3 y + 6\epsilon_1 x^2 y^2 + 4xy^3 + \epsilon_1 y^4) \frac{\partial f}{\partial y} \equiv (0, 2ax^5 + 5\epsilon_2 x^4 y + 6\epsilon_1 \epsilon_2 x^3 y^2 + 4\epsilon_2 x^2 y^3 + \epsilon_1 \epsilon_2 xy^4)$$

$$(5) \quad (0, f_1 f_2^3) \equiv (0, a^2 x^5 + a(\epsilon_2 + \epsilon_1 a) x^4 y + (1 + 2\epsilon_1 \epsilon_2) x^3 y^2 + \epsilon_1 x^2 y^3).$$

These vectors are generated by $(0, x^5), (0, x^4 y), (0, x^3 y^2), (0, x^2 y^3), (0, xy^4)$. For $a \neq 0, \frac{\epsilon_1 \epsilon_2}{2}, \epsilon_1 \epsilon_2$, they are linearly independent. Therefore their generators are in

$T_Y \mathcal{A}_1.f$ modulo $m_3^6.C_3^{\times 2}$. Using $(0, f_1^5)$ we show that $(0, y^5) \in T_Y \mathcal{A}_1.f$ modulo $m_3^6.C_3^{\times 2}$.

The above vectors depend only on $j^2 f$. In fact, using other vectors which depend on the 3-jet of f , we can show that the values $0, \frac{\epsilon_1 \epsilon_2}{2}$ for a are not exceptional.

Similar calculations show that all monomials of degree 4 are in $T_Y \mathcal{A}_1.f$ modulo $m_3^6.C_3^{\times 2}$. Thus, f is 3- $Y \mathcal{A}$ -determined provided $a \neq \epsilon_1 \epsilon_2$. We have also proved that $j^2 f = (x + \epsilon_1 y, z + \epsilon_2 xy + ax^2)$ is 3- $Y \mathcal{A}$ -determined provided $a \neq 0, \frac{\epsilon_1 \epsilon_2}{2}, \epsilon_1 \epsilon_2$. This is going to be useful for the topological versality calculations in Proposition 2.4.2.

Calculations show that $T_Y \mathcal{A}_e.f \oplus R.\{(0, x), (0, x^2)\} = V(f)$. The codimension of f is 2.

(2). When $a = \epsilon_1 \epsilon_2$, the 3-jet $f = (x + \epsilon_1 y, z + \epsilon_2 xy + ax^2 + \epsilon_3 x^3)$ is not 3- $Y \mathcal{A}$ -determined. A complete 4-transversal is $R.\{(0, y^4)\}$. There is 1-parameter family of orbits in the in the 4-jet with 3-jet as f , that is $(x + \epsilon_1 y, z + \epsilon_2 xy + \epsilon_1 \epsilon_2 x^2 + \epsilon_3 x^3 + ay^4)$. The germ $(x + \epsilon_1 y, z + \epsilon_2 xy + \epsilon_1 \epsilon_2 x^2 + \epsilon_3 x^3 + ay^4)$ is 4- $Y \mathcal{A}$ -determined provided $a \neq -\frac{3}{8} \epsilon_1 \epsilon_2$. The calculation here are quite messy, we shall omit them. In this case $l = 3$ and $k = 4$ in Corollary 1.2.3, and $T_Y \mathcal{A}_e.f \oplus R.\{(0, y), (0, y^2), (0, y^4)\} = V(f)$.

(3). Let $j^{k-1} f = (x + \epsilon_1 y, z + \epsilon_2 x^2)$. Then $x \frac{\partial f}{\partial x} = (x, \epsilon_2 x^2), y \frac{\partial f}{\partial y} = (\epsilon_1 y, 0), z \frac{\partial f}{\partial z} = (0, z)$. It is clear that a complete k -transversal is $R.\{(0, y^k)\}$. Any k -jet with $(k-1)$ -jet as f is $Y \mathcal{A}$ -equivalent to $(x + \epsilon_1 y, z + \epsilon_2 x^2 + \epsilon_3 y^k)$ or $(x + \epsilon_1 y, z + \epsilon_2 x^2)$.

Let f denotes the k -jet $(x + \epsilon_1 y, z + \epsilon_2 x^2 + \epsilon_3 y^k)$. Then

$$\begin{aligned} x \frac{\partial f}{\partial x} &= (x, \epsilon_2 x^2) \\ y \frac{\partial f}{\partial y} &= (\epsilon_1 y, \epsilon_3 k y^k) \\ z \frac{\partial f}{\partial z} &= (0, z) \end{aligned}$$

It is not difficult to show that $m_3^2.C_3^{\times 2} \subset C_3.\{x \frac{\partial f}{\partial x}, y \frac{\partial f}{\partial y}, z \frac{\partial f}{\partial z}\} + f^*m_2.C_2^{\times 2} + m_3^3.C_3^{\times 2}$.

Hence $l = 2$ in Corollary 1.2.3. We need to prove that $m_3^k.C_3^{\times 2} \subset T_Y \mathcal{A}_1.f + m_3^{k+3}.C_3^{\times 2}$. It is clear from the expressions of $x \frac{\partial f}{\partial x}, y \frac{\partial f}{\partial y}, z \frac{\partial f}{\partial z}$ and $(0, f_1^p)$ that it

is enough prove that $(0, y^{k+2})$ and $(0, y^{k+1})$ are in $T_Y \mathcal{A}_1.f$ modulo $m_3^{k+3}.C_3^{\times 2}$.

$$\text{We have } V = (x^3 + 3xy^2) \frac{\partial f}{\partial x} + y^3 \frac{\partial f}{\partial y} - (f_1^3, 0) = (0, 2\epsilon_2 x^4 - 6\epsilon_2 x^2 y^2 + \epsilon_3 k y^{k+2}).$$

Now the vectors

$$(1). V = (0, 2\epsilon_2 x^4 - 6\epsilon_2 x^2 y^2 + \epsilon_3 k y^{k+2})$$

$$(2). (0, f_1^2 f_2) = (0, \epsilon_2 x^4 + \epsilon_1 x^2 y^2 + 2\epsilon_1 \epsilon_2 x y^{k+1} + \epsilon_3 y^{k+2})$$

$$(3). (0, f_1^{k+2}) = (0, \epsilon_1(k+2)xy^{k+1} + y^{k+2})$$

$$(4). xy^2(\epsilon_1 \frac{\partial f}{\partial x} - \frac{\partial f}{\partial y}) = (0, 2\epsilon_1\epsilon_2x^2y^2 - \epsilon_3kxy^{k+1})$$

are linearly independent. Hence, $(0, y^{k+2}) \in T_Y \mathcal{A}_1.f + m_3^{k+3}.C_3^{\times 2}$.

Now if we use the following vectors : $(x^2 + 2xy)\frac{\partial f}{\partial x} + y^2\frac{\partial f}{\partial y} - (f_1^2, 0)$; $(0, f_1f_2)$; $(0, f_1^{k+1})$; $xy(\epsilon_1 \frac{\partial f}{\partial x} - \frac{\partial f}{\partial y})$, we show that $(0, y^{k+1}) \in T_Y \mathcal{A}_1.f + m_3^{k+3}.C_3^{\times 2}$.

Note that $T_Y \mathcal{A}_e.f \oplus R.\{(0, y), (0, y^2), \dots, (0, y^{k-1})\} = V(f)$, the codimension of f is $k - 1$. \square

The 1-jet (x, y)

A complete 2-transversal is $R.\{(yz, 0), (z^2, 0), (0, xz), (0, z^2)\}$. There is a family of orbits in the 3-jet with 1-jet (x, y) which is relevant for our investigation, that is $(x + \epsilon_1yz + \epsilon_2z^2, y + \epsilon_3xz + az^2)$. The orbits in the 3-jet with 2-jet $(x + \epsilon_1yz + \epsilon_2z^2, y + \epsilon_3xz + az^2)$ are $(x + \epsilon_1yz + \epsilon_2z^2, y + \epsilon_3xz + az^2 + bz^3)$.

2.3.3. Proposition : *The germ $(x + \epsilon_1yz + \epsilon_2z^2, y + \epsilon_3xz + az^2 + bz^3)$ is 3-determined provided $a \neq 0, b \neq 0$. Its codimension is 4 with a and b moduli. This is the case V in Table 2.*

The proof of this proposition follows using Corollary 1.2.3. Here $l = 2$ and $k = 3$ provided $a \neq 0$ and $b \neq 0$. We also have $T_Y \mathcal{A}_e.f \oplus R.\{(z, 0), (0, z), (0, z^2), (0, z^3)\} = V(f)$. The codimension of f is 4.

§4. The geometry of the normal forms in Table 2

In this section we describe the geometry of the germs in Table 2. As in Chapter 1, we shall give a versal unfolding of the germ and a realization of it in terms of a family of parallel projections of a generic triple of surfaces. We draw the “critical sets” of nearby germs by varying the unfolding parameters in a neighbourhood of the origin.

Corners occur at isolated points on generic triples of surfaces. For singularities of codimension less than two of orthogonal projections, one expects only singularities of codimension less than 1 in Table 1 to occur at the corner point on one of the creases. As in Chapter 1, we expect a case of codimension 2 (plus moduli) to occur when two of the surfaces forming the corner have a common tangent space at the origin. For lack of bravery to face the calculations, this case is not dealt with algebraically (it is excluded from the context by imposing on the three surfaces to meet transversally !). We shall sketch its geometry at the end of this section.

The notation here is similar to that in §4 in Chapter 1. For a given germ in Table 2, we want to realize its unfolding f in terms of a family of parallel projections of a generic triple of surfaces. That is finding i such that the following diagram commutes.

$$\begin{array}{ccc}
 & & R^3, 0 \\
 & i \nearrow & \downarrow \pi_{(-\lambda, -\mu)} \\
 R^3, 0 \times R^2, 0 & \xrightarrow{f} & R^2, 0
 \end{array}$$

Here $\pi_{(-\lambda, -\mu)}$ denotes the projection on the plane $z = 0$ in the direction $(-\lambda, -\mu, 1)$.

We denote by M the image by i of the model Y of triples of surfaces. We write $M = M_1 \cup M_2 \cup M_3$ with $M_j = i(Y_j)$. The three creases are denoted by C_1 for $M_1 \cap M_2$, C_2 for $M_2 \cap M_3$ and C_3 for $M_3 \cap M_1$. The *corner* is $C = C_1 \cup C_2 \cup C_3$. The critical sets of $f|_{M_i}$ are denoted by Σ_i . The *critical set* of f is then $\Sigma = C \cup \Sigma_1 \cup \Sigma_2 \cup \Sigma_3$ and its image is the *critical locus* of f . We draw the image of the corner with a thick line and the profiles with a thin line. The dashed lines refer to the invisible parts of the critical locus.

2.4.1. Remarks : In addition to Remarks 1.4.4 in Chapter 1, we have

- (1). If $f(C_i)$ are smooth, then at most one of the Σ_i is non-empty.
- (2). If $f(C_1)$ is singular, then Σ_1 and Σ_2 are not empty and Σ_3 is empty.

Proof: (1). Since f is a germ of a submersion, the tangents to the images of creases span the plane R^2 .

If $f(C_i)$ are pairwise transverse, then $f|_{Y_i}$ ($i = 1, 2, 3$) are of maximal rank. Thus Σ_i ($i = 1, 2, 3$) are empty.

If two of the $f(C_i)$ are tangential, say $f(C_1)$ and $f(C_2)$, then $f|_{Y_1}$ and $f|_{Y_3}$ are of maximal rank. That is $\Sigma_1 = \Sigma_2 = \emptyset$. The germ $f|_{Y_2}$ is of rank 1, therefore Σ_3 is non-empty.

(2). When $f(C_1)$ is singular, $f|_{Y_1}$ and $f|_{Y_2}$ are singular. Hence Σ_1 and Σ_2 are non-empty. The set Σ_3 is empty because f is a submersion. \square

Case I. Stable corner

The germ $(x + \epsilon_1 z, y + \epsilon_2 z)$ is $Y\mathcal{A}$ stable. It is realized by $i(x, y, z) = (x + \epsilon_1 z, y + \epsilon_2 z, z)$. The image of the corner is $\{(\epsilon_1 z, \epsilon_2 z), z \geq 0\} \cup \{(0, y), y \geq 0\} \cup \{(x, 0), x \geq 0\}$.

Case II. C- semi-fold

An $Y\mathcal{A}$ -versal unfolding of the germ is $f = (x + \epsilon_1 y, z + \epsilon_2 xy + ax^2 + \epsilon_3 x^3 + \lambda x)$. This unfolding is realized by $i(x, y, z) = (x + \epsilon_1 y, z + \epsilon_2 xy + ax^2 + \epsilon_3 x^3, x)$.

The image of the corner is $\{(0, z), z \geq 0\} \cup \{(\epsilon_1 y, 0), y \geq 0\} \cup \{(x, ax^2 + \epsilon_3 x^3 + \lambda x), x \geq 0\}$. The last two creases are tangential at the origin. The critical set of $f|_{Y_1}$ is given by $y = -\epsilon_2(\lambda + (2a - \epsilon_1 \epsilon_2)x + 3\epsilon_3 x^2)$. Its image is parametrized by $x \mapsto (2(1 - \epsilon_1 \epsilon_2 a)x - 3\epsilon_1 \epsilon_2 \epsilon_3 x^2, (\epsilon_1 \epsilon_2 - a)x^2 - 2\epsilon_3 x^3)$.

When $a \neq \epsilon_1 \epsilon_2$, $(0,0,1)$ is not an asymptotic direction at the origin and the profile is smooth.

At $\lambda = 0$, the profile $f(\Sigma_1)$ and the images of the creases C_1 and C_3 are tangential. When λ moves away from the origin, $f(C_i)$ become pairwise transverse and meet in a corner of type I (figure 2.4.1). On one of the creases lies the profile away from the corner (this is a singularity of type II in Table 1 in Chapter 1).

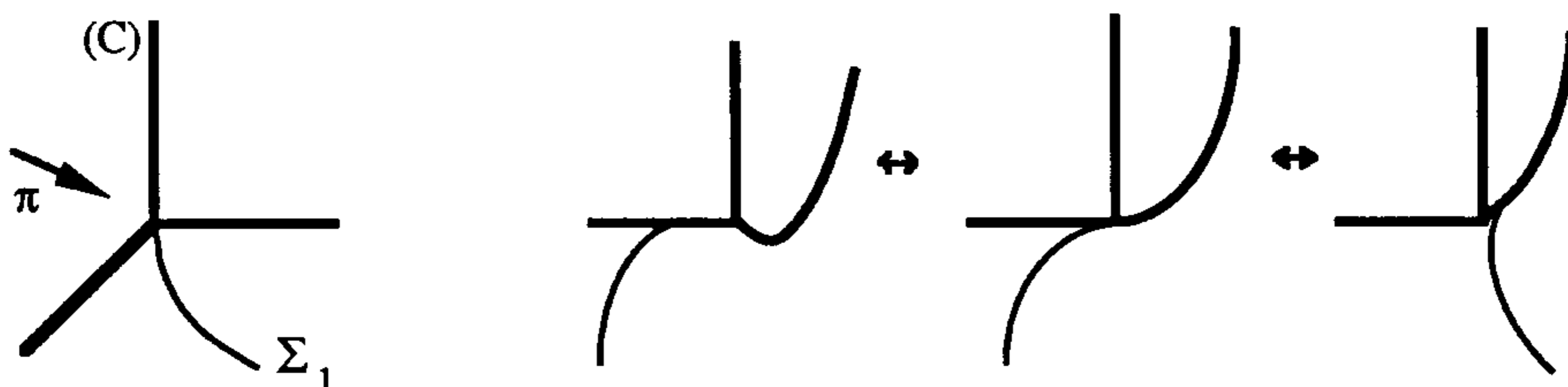

Figure 2.4.1. C- Semi-fold

The geometry of the germ $(x + \epsilon_1 y, z + \epsilon_2 xy + ax^2 + \epsilon_3 x^3)$ does not vary when the modulus a changes locally. We use Damon's results on topological versality to show that the unfolding $(x + \epsilon_1 y, z + \epsilon_2 xy + ax^2 + \lambda x)$ is topologically versal. As pointed out in the proof of Proposition 2.3.2 (1), the germ $f_0 = (x + \epsilon_1 y, z + \epsilon_2 xy + ax^2)$ is 4- $\mathcal{Y}\mathcal{A}$ -determined provided $a \neq 0, \frac{\epsilon_1 \epsilon_2}{2}, \epsilon_1 \epsilon_2$. If we assign weights to the variables x, y, z such that $wt(x) = wt(y) = 1$ and $wt(z) = 2$, then f_0 is weighted homogeneous. Thus $(x + \epsilon_1 y, z + \epsilon_2 xy + ax^2 + \epsilon_3 x^3)$ is semi-weighted homogeneous.

2.4.2. Proposition : *The unfolding $(x + \epsilon_1 y, z + \epsilon_2 xy + ax^2 + \lambda x)$ is topologically versal provided $a \neq 0, \frac{\epsilon_1 \epsilon_2}{2}, \epsilon_1 \epsilon_2$.*

Proof : The stratification condition is trivially satisfied here since f_0 is a germ of a submersion. The germ f_0 is 4- $\mathcal{Y}\mathcal{A}$ -determined provided $a \neq 0, \frac{\epsilon_1 \epsilon_2}{2}, \epsilon_1 \epsilon_2$. All that we have to prove is that the unfolding $(x + \epsilon_1 y, z + \epsilon_2 xy + ax^2 + \lambda x)$ is of finite codimension. Well, an unfolding of f_0 is $f(x, y, z, a, b, \lambda) = (x + \epsilon_1 y, z + \epsilon_2 xy + ax^2 + bx^3 + \lambda x)$, and a negative versal unfolding is $f_+(x, y, z, \lambda) = (x + \epsilon_1 y, z + \epsilon_2 xy + ax^2 + \lambda x)$. The Euler relation for f_+ is $e(f_+) = (0, \lambda x)$. The minor of the vector $x.e(f_+) = (0, \lambda x^2)$ with respect to the basis $(0, x^2)$ is λ . This generates an ideal of finite codimension in C_λ . The proposition then follows by Theorem 1.5.1 in Chapter 1. \square

2.4.3. Remark : One can explain geometrically why the values $0, \frac{\epsilon_1 \epsilon_2}{2}, \epsilon_1 \epsilon_2$ of the modulus a are exceptional.

For $a = 0$, the image of the crease C_1 has a higher contact with the image of the crease C_3 .

When $a = \frac{\epsilon_1 \epsilon_2}{2}$, the critical set Σ_1 is tangent to the crease C_1 . This is the condition to have a C-semi-lips/beaks singularity. In fact when $a = \frac{\epsilon_1 \epsilon_2}{2}$, the 2-jet $(x + \epsilon_1 y, z + \epsilon_2 xy + ax^2)$ is equivalent to $(x + \epsilon_1 y, z + \epsilon_2 y^2)$ or, by interchanging the surfaces Y_1 and Y_2 , to $(x + \epsilon_1 y, z + \epsilon_2 x^2)$. We recognize on this the 2-jet of the germ IV in Table 2.

When $a = \epsilon_1 \epsilon_2$, the direction of projection is an asymptotic direction. The profile has an ordinary cusp.

For each of the above values of a , an extra condition is added to the germ f . That is why they are exceptional for the family f_a .

Case III. C- semi-cusp

An $\mathcal{Y}\mathcal{A}$ -versal unfolding of the germ is $(x + \epsilon_1 y, z + \epsilon_2 xy + \epsilon_1 \epsilon_2 x^2 + \epsilon_3 x^3 + ay^4 + \lambda y + \mu y^2)$. An equivalent unfolding is realized by $i(x, y, z) = (x + \epsilon_1 y, z + \epsilon_2 xy + \epsilon_1 \epsilon_2 x^2 + \epsilon_3 x^3 + ay^4, y + y^2)$.

Taking the first considered unfolding, the image of the corner $\{(0, z), z \geq 0\} \cup \{(\epsilon_1 y, ay^4 + \lambda y + \mu y^2), y \geq 0\} \cup \{(x, \epsilon_1 \epsilon_2 x^2 + \epsilon_3 x^3), x \geq 0\}$. The restriction of f to Y_1 is singular and its singular points satisfy the equation

$$3\epsilon_1 \epsilon_3 x^2 + 2\epsilon_2 x - \lambda - (2\mu - \epsilon_1 \epsilon_2)y - 4ay^3 = 0 \quad (*)$$

At $\lambda = \mu = 0$, $(0,0,1)$ is an asymptotic direction to the surface M_1 . The profile has a cusp at the origin and the projection of the two creases C_1 and C_3 are tangential. On the μ -axis the projection of the two creases and the profile remain tangential, this is a singularity of type II in Table 2. There is another special curve in the (λ, μ) -parameter space where the cusp on the fold lies on one of the creases. This is a singularity of type IV in Table 1 in Chapter 1. It happens when the profile is singular and the singular point is on the x -axis or y -axis in the source. Using the equation $(*)$ we find that the curve is $(\lambda, \mu) = (\epsilon_1 \epsilon_2 y + 8ay^3, -6ay^2)$ for the cusp to lie on $\{(\epsilon_1 y, ay^4 + \lambda y + \mu y^2), y \geq 0\}$, and $(\lambda, \mu) = (3\epsilon_2 \epsilon_3 x^2 + \epsilon_2 x, 3\epsilon_3 x)$ for the cusp to lie on $\{(x, \epsilon_1 \epsilon_2 x^2 + \epsilon_3 x^3), x \geq 0\}$ (figure 2.4.2).

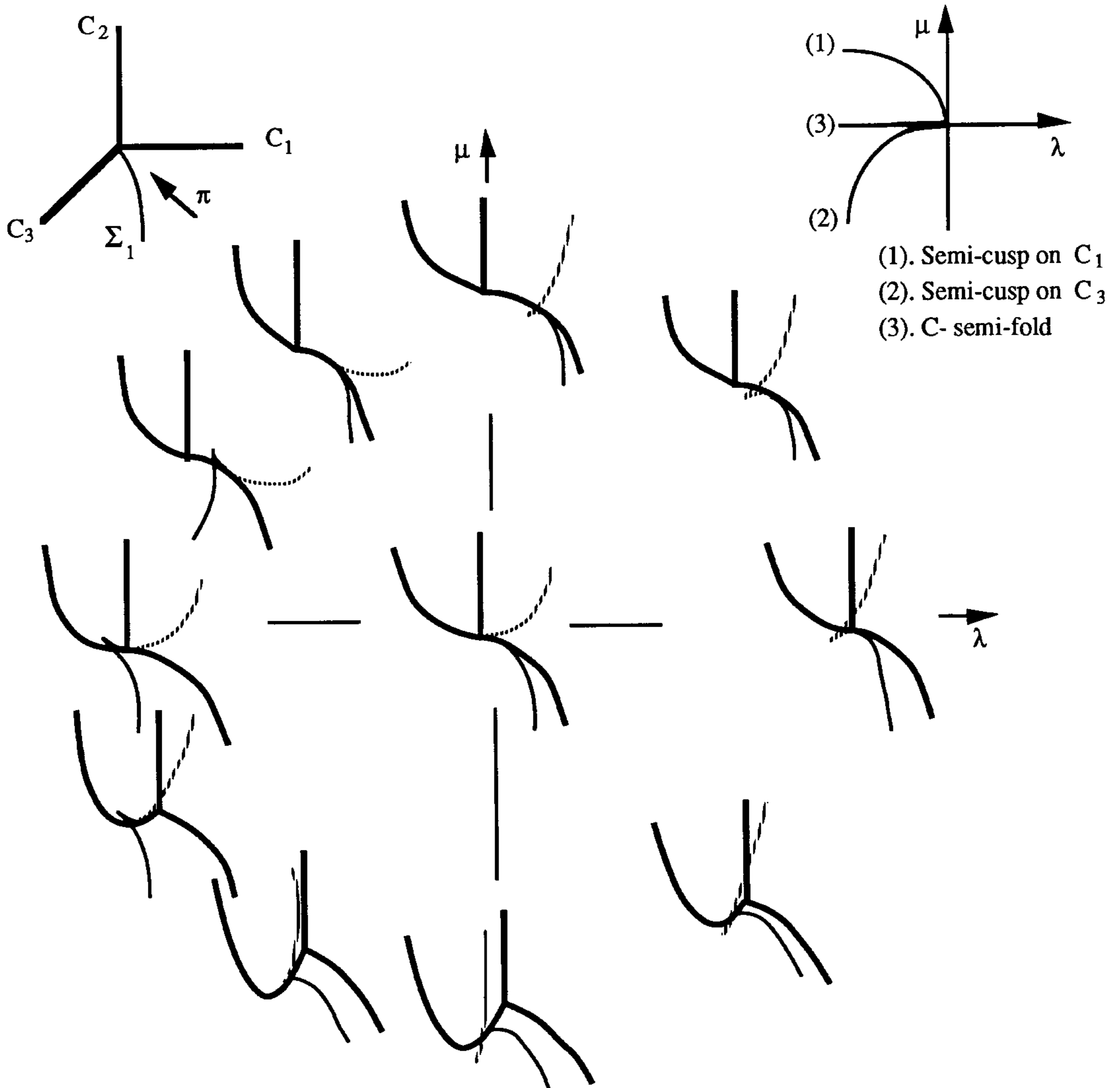

Figure 2.4.2. C- Semi-cusp

Case IV. $k=3$ C- semi-lips/beaks

An γ - \mathcal{A} -versal unfolding of the germ is $(x + \epsilon_1 y, z + \epsilon_2 x^2 + \epsilon_3 y^3 + \lambda y + \mu y^2)$. The germ $(x + \epsilon_1 y, z + \epsilon_2 x^2 + \epsilon_3 y^3)$ does not have a symmetrical unfolding. An equivalent germ is realized by $i(x, y, z) = (x + \epsilon_1 y, z - 2\epsilon_1 \epsilon_2 xy - \epsilon_2 y^2 + \epsilon_3 y^3, x + x^2)$.

If we consider the first unfolding, the image of the corner is $\{(0, z)\} \cup \{(\epsilon_1 y, \epsilon_3 y^3 + \lambda y + \mu y^2)\} \cup \{(x, \epsilon_2 x^2)\}$. The singular set of this unfolding when restricted to Y_1 is defined by the equation

$$x = -\frac{1}{2}\epsilon_1 \epsilon_2 (\lambda + 2\mu y + 3\epsilon_3 y^2) \quad (*)$$

At $\lambda = \mu = 0$, the critical set and the crease $\{(0, y, 0)\}$ are tangential, semi-lips/beaks occur on the critical locus of $f|_{Y_1}$. (Semi-lips when $\epsilon_1 \epsilon_2 \epsilon_3 = +1$ and

semi-beaks when $\epsilon_1\epsilon_2\epsilon_3 = -1$.) The projection of the creases forming the surface M_1 and the profile are tangential at the origin. The projection of the creases remain tangential when $\lambda = 0$, this is a singularity of type II in Table 2. The critical set of $f|_{Y_1}$ is tangent to the crease C_1 when $3\epsilon_3\lambda - \mu^2 = 0$. For (λ, μ) on this curve, semi-lips/beaks (singularity of type III in Table 1 in Chapter 1) occur on the projection of the surface M_1 (figure 2.4.3).

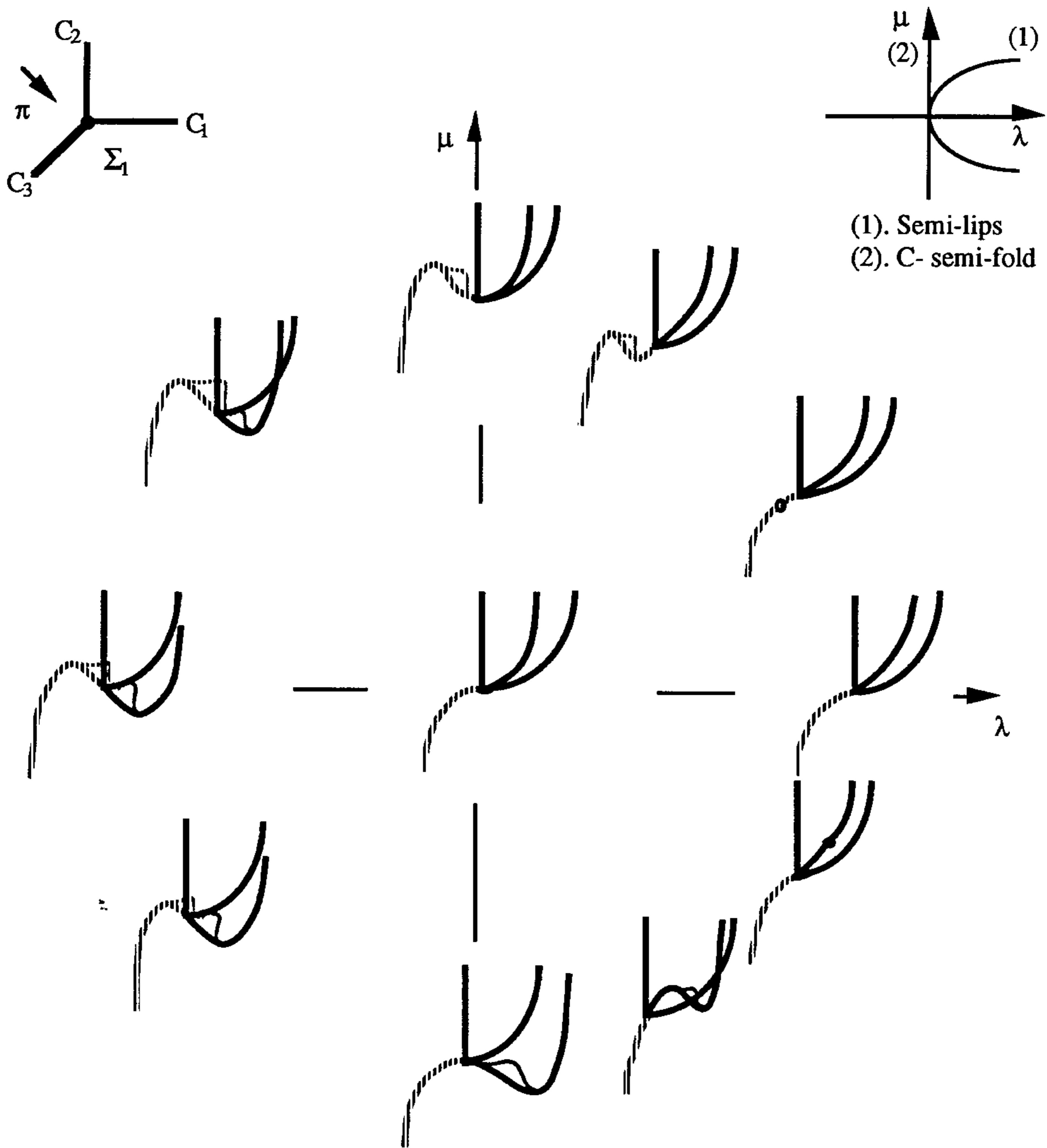

Figure 2.4.3. C- Semi-lips

Case V. C- crease cusp

An $\mathcal{Y}\mathcal{A}$ versal unfolding of the germ is $(x + \epsilon_1xy + \epsilon_2z^2 + \lambda z, y + \epsilon_3xz + az^2 + bz^3 + \mu z)$. This unfolding is realized by $i(x, y, z) = (x + \epsilon_1xy + \epsilon_2z^2, y + \epsilon_3xz + az^2 + bz^3, z)$.

The image of the corner is $\{(\lambda z + \epsilon_2z^2, \mu z + az^2 + bz^3)\} \cup \{(0, y)\} \cup \{(x, 0)\}$. The critical set of $f|_{Y_3}$ is given by the equation $x = -\epsilon_3\mu + (\lambda - 2a\epsilon_3)z + (2\epsilon_2 - 3b\epsilon_3)z^2$, and the critical set of $f|_{Y_2}$ is given by the equation $y = -\epsilon_1\lambda + (\mu - 2\epsilon_1\epsilon_2)z + 2az^2 + 3bz^3$.

At $\lambda = \mu = 0$, $(0,0,1)$ is tangent to the crease C_2 at a point of non-zero torsion. The projection of the crease has an ordinary cusp at the origin (provided $b \neq 0$). The crease remains singular on the curve $(\lambda, \mu) = (-2\epsilon_2 z, -2az - 3bz^2)$. On the λ -axis and μ -axis, C- semi-fold singularities occur (figure 2.4.4).

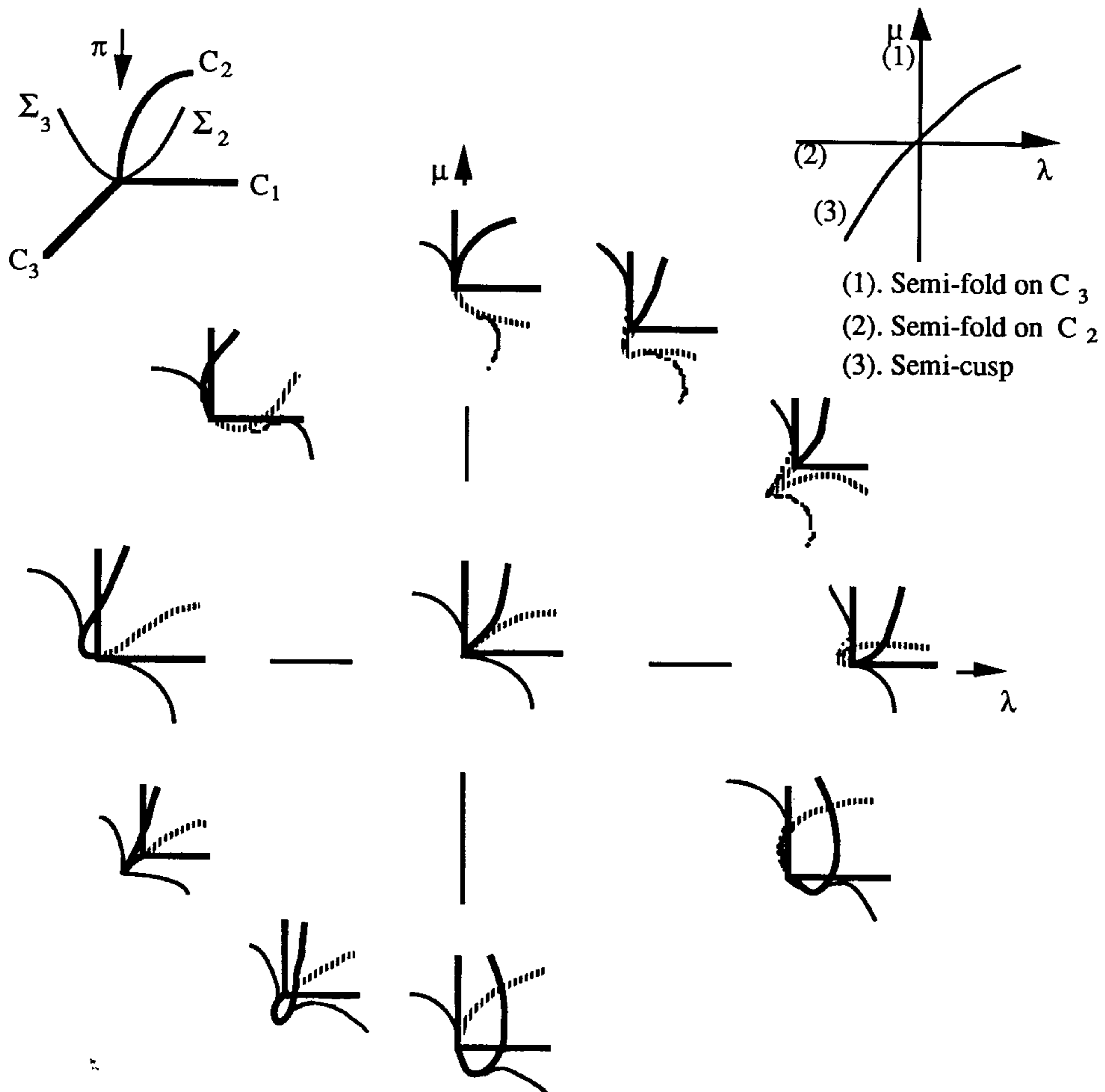

Figure 2.4.4. C-crease-cusp

The missing case. Non-transverse C- semi-fold

When two of the surfaces forming the corner have a common tangent space at the origin and f is singular on both of them, f is of rank 1. This case cannot be realized as a family of orthogonal projections of a generic triple of surfaces. One has to consider an orthogonal projection of 2-parameter family of triples of surfaces $M_{\lambda, \mu} = M_{\lambda, \mu}^1 \cup M_{\lambda, \mu}^2 \cup M_{\lambda, \mu}^3$, with for example $M_{0,0}^2$ and $M_{0,0}^3$ having the same tangent plane at the corner point. We can think of the family $M_{\lambda, \mu}$ as the combination of the slipping of the surface $M_{0,0}^2$ along its common boundary with the surface $M_{0,0}^2$ and the changing of “height” of the surface $M_{0,0}^1$ with respect to this boundary.

This case, that we call *non-transverse C- semi-fold*, is of codimension 2 (plus

moduli). We expect a curve in the parameter space (λ, μ) where the first two surfaces still have a common tangent plane but away from the corner. These are the non-transverse semi-fold singularities in Table 1 in Chapter 1. We also expect two other special curves where C- semi-fold singularities occur on two different creases (figure 2.4.5).

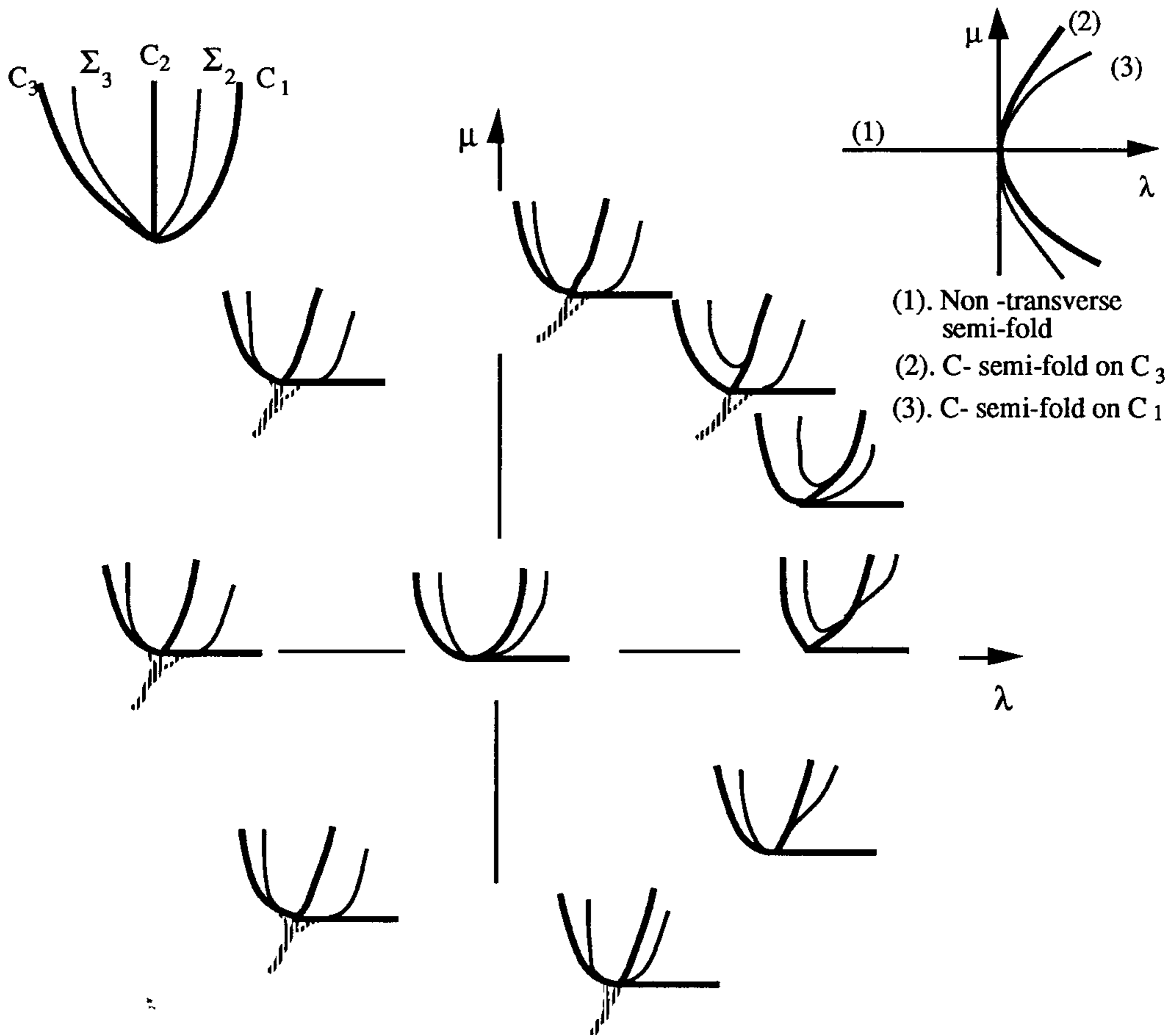

Figure 2.4.5. Non-transverse C- semi-fold

Chapter 3

Recognition of smooth map germs from the plane to the plane

§1. Introduction

Map germs from the plane to the real plane have been extensively studied for the last thirty years. Their investigation started with Whitney in 1955 [Wh]. He considered explicit smooth changes of coordinates in the source and target and found that there are three stable maps

(x, y)	Diffeomorphism map
(x, y^2)	Fold map
$(x, xy - y^3)$	Cusp map

After Mather's work on determinacy and the improvement of his estimates, it was possible to carry out the classification further and obtain a list of orbits of germs low codimensions. Extensive work was done in this direction (see §1 in Chapter 1 for references), and recently J. H. Rieger obtained a Table of germs of codimension less than 6 [R1].

For any germ F of rank greater than 1 and of low codimension, there are diffeomorphisms h and k from the plane to the plane such that $k \circ F \circ h^{-1}$ is one of the germs in Rieger's Table. In practice for a given germ f , it is very difficult to find explicitly the diffeomorphisms h and k and hence "recognize" the singularity type of the map F .

In this chapter, we extend Yun-Chen Lu's criteria [Lu] for recognition of fold maps and cusp maps to germs of codimensions 1. When the critical set Σ of a germ F is smooth, the method consists of looking at the order of contact of Σ with the kernel of $DF(0,0)$ at the origin. When the critical set is singular, *i.e.*, consists of an isolated point or a node, an additional algebraic condition is needed to recognize the germ. For germs of codimension greater than 1 this criterion is not sufficient for their recognition.

The criterion we present here is weak as it does not give a systematic way of recognizing map germs from the plane to the plane, but it is of a big help in Chapter 5 when we study the transitions in 1-parameter families of *Rotational Symmetry Sets*.

We denote by $C_2^{\times 2}$ the set of smooth map-germs $F : R^2, 0 \rightarrow R^2, 0$ and by \mathcal{A} the Mather group of germs of diffeomorphisms at the origin in the source and target. When F is of rank ≥ 1 , we can change coordinates in the source and target and write $F(x, y) = (x, f(x, y))$ (see [Br-L]). The differential of F at a point (x, y) is then

$$DF(x, y) = \begin{pmatrix} 1 & 0 \\ \frac{\partial f}{\partial x}(x, y) & \frac{\partial f}{\partial y}(x, y) \end{pmatrix}$$

The map F is singular at (x, y) if and only if $\frac{\partial f}{\partial y}(x, y) = 0$. The critical set of F is

$$\Sigma = \{(x, y) : \frac{\partial f}{\partial y}(x, y) = 0\}$$

By the Inverse Function Theorem, the critical set Σ is smooth if and only if $\frac{\partial^2 f}{\partial y^2}(0, 0) \neq 0$ or $\frac{\partial^2 f}{\partial x \partial y}(0, 0) \neq 0$. We take $\phi : I \rightarrow R^2$ as a local parametrization of Σ when it is smooth, where I denotes an open neighbourhood of 0 in R . The *order of contact* of Σ with the kernel line of $DF(0, 0)$, $\ker(DF(0, 0))$, is the order of vanishing of the derivatives of $F \circ \phi$ at 0.

3.1.1. Lemma : (i). *The order of contact of Σ with $\ker(DF(0, 0))$ is independent of the parametrization of Σ .*

(ii). *When Σ is smooth its order of contact with $\ker(DF(0, 0))$ is an \mathcal{A} -invariant.*

Proof: (i). Let ϕ and ψ two local parametrization of Σ at the origin. Then $F \circ \psi = F \circ \phi \circ (\phi^{-1} \circ \psi)$ with $(\phi^{-1} \circ \psi)(0) = 0$ and $(\phi^{-1} \circ \psi)'(0) \neq 0$. It is clear that $(F \circ \psi)(0) = (F \circ \psi)'(0) = \dots = (F \circ \psi)^{(n)}(0) = 0$ and $(F \circ \psi)^{(n+1)}(0) \neq 0$ if and only if $(F \circ \phi)(0) = (F \circ \phi)'(0) = \dots = (F \circ \phi)^{(n)}(0) = 0$ and $(F \circ \phi)^{(n+1)}(0) \neq 0$.

(ii). Let G be an \mathcal{A} -equivalent germ to F . We can write $G = k \circ F \circ h$ for some (h, k) in \mathcal{A} . Let ϕ and ψ be parametrizations of the critical sets Σ_G of G and Σ_F of F respectively. We have $DG(x, y) = Dk(F(h(x, y))).DF(h(x, y)).Dh(x, y)$, and since h and k are germs of diffeomorphisms it follows that $(x, y) \in \Sigma_G$ if and only if $h(x, y) \in \Sigma_F$. That is $\Sigma_F = h(\Sigma_G)$. Let ϕ be a parametrization of Σ_G , then $h \circ \phi$ is parametrization of Σ_F . Now in the above expression of DG in terms of DF we deduce that $(G \circ \psi)(0) = (G \circ \psi)'(0) = \dots = (G \circ \psi)^{(n)}(0) = 0, (G \circ \psi)^{(n+1)}(0) \neq 0$ if and only if $(F \circ (h \circ \phi))(0) = (F \circ (h \circ \phi))'(0) = \dots = (F \circ (h \circ \phi))^{(n)}(0) = 0, (F \circ (h \circ \phi))^{(n+1)}(0) \neq 0$, which proves the assertion. \square

§2. Recognition of fold and cusp maps

Let ϕ be a local parametrization of the critical set Σ .

3.2.1. Definition : (5.2 page 38 in [Lu]).

(i) The map F is a fold map if $\frac{d}{dt}(F \circ \phi)(0) \neq 0$.

(ii) The map F is a cusp map if $\frac{d}{dt}(F \circ \phi)(0) = 0$ and $\frac{d^2}{dt^2}(F \circ \phi)(0) \neq 0$.

3.2.2. Remark : The conditions given in Definition 3.2.1 reflect the order of contact of Σ with the kernel of $DF(0,0)$, $Ker(DF(0,0))$. The map F is a fold map if and only if Σ and $Ker(DF(0,0))$ are transverse at the origin. It is a cusp map if and only if they have 2-point contact at the origin as in (figure 3.2.1).

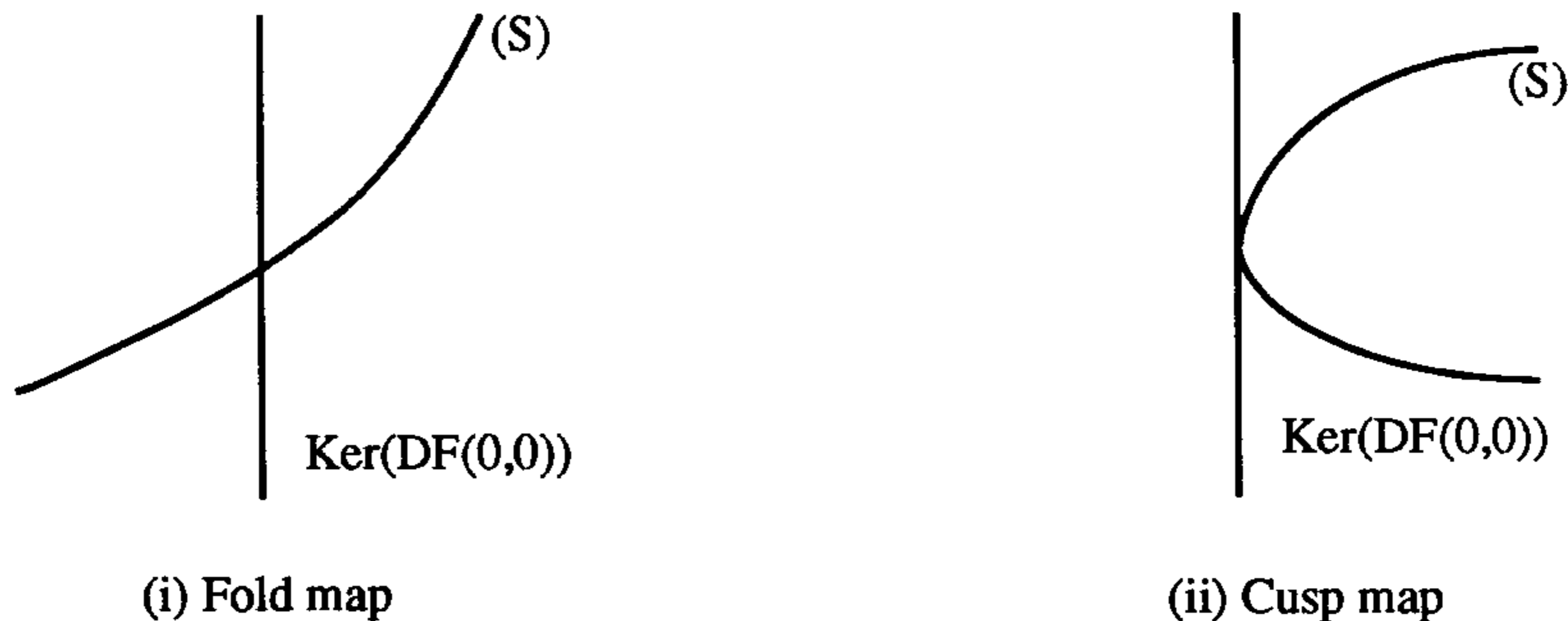

Figure 3.2.1

3.2.3. Proposition : Let $F : R^2,0 \rightarrow R^2,0$ be a smooth map germ with $F(x,y) = (x, f(x,y))$. Then,

(i) F is a fold map if and only if $\frac{\partial f}{\partial y}(0,0) = 0$ and $\frac{\partial^2 f}{\partial y^2}(0,0) \neq 0$.

(ii) F is a cusp map if and only if $\frac{\partial f}{\partial y}(0,0) = \frac{\partial^2 f}{\partial y^2}(0,0) = 0$, $\frac{\partial^2 f}{\partial x \partial y}(0,0) \neq 0$ and $\frac{\partial^3 f}{\partial y^3}(0,0) \neq 0$.

Proof: Whitney (1955) [Wh].

3.2.4. Proposition : Definition 3.2.1 and Proposition 3.2.3 are equivalent.

Proof: Let $F(x,y) = (x, f(x,y))$ with a critical set $\Sigma = \{(x,y) : \frac{\partial f}{\partial y}(x,y) = 0\}$.

Let $(-\frac{\partial^2 f}{\partial y^2}(x,y), \frac{\partial^2 f}{\partial x \partial y}(x,y))$ be a vector field tangent to Σ , and $\phi : I \rightarrow R^2$

a local parametrization of Σ satisfying $\frac{d}{dt}\phi(t) = (-\frac{\partial^2 f}{\partial y^2}(\phi(t)), \frac{\partial^2 f}{\partial x \partial y}(\phi(t)))$. By

definition $\frac{\partial f}{\partial y}(\phi(t)) = 0$. We have

$$\begin{aligned}
\frac{d}{dt}(F \circ \phi)(t) &= DF(\phi(t)) \cdot \frac{d}{dt}\phi(t) \\
&= \begin{pmatrix} 1 & 0 \\ \frac{\partial f}{\partial x}(\phi(t)) & \frac{\partial f}{\partial y}(\phi(t)) \end{pmatrix} \begin{pmatrix} -\frac{\partial^2 f}{\partial y^2}(\phi(t)) \\ \frac{\partial^2 f}{\partial x \partial y}(\phi(t)) \end{pmatrix} \\
&= \begin{pmatrix} \frac{\partial^2 f}{\partial y^2}(\phi(t)) \\ -\frac{\partial f}{\partial x}(\phi(t)) \cdot \frac{\partial^2 f}{\partial y^2}(\phi(t)) + \frac{\partial f}{\partial y}(\phi(t)) \cdot \frac{\partial^2 f}{\partial x \partial y}(\phi(t)) \end{pmatrix} \\
&= -\frac{\partial^2 f}{\partial y^2}(\phi(t)) \cdot \begin{pmatrix} 1 \\ \frac{\partial f}{\partial x}(\phi(t)) \end{pmatrix} \quad (*)
\end{aligned}$$

At the origin, $\phi(0) = (0, 0)$. Thus, $\frac{d}{dt}(F \circ \phi)(0) = -\frac{\partial^2 f}{\partial y^2}(0, 0) \cdot \begin{pmatrix} 1 \\ \frac{\partial f}{\partial x}(0, 0) \end{pmatrix}$.

Hence $\frac{d}{dt}(F \circ \phi)(0) \neq 0 \iff \frac{\partial^2 f}{\partial y^2}(0, 0) \neq 0$.

If we differentiate (*), we get

$$\begin{aligned}
\frac{d^2}{dt^2}(F \circ \phi)(t) &= \frac{d}{dt} \left(-\frac{\partial^2 f}{\partial y^2}(\phi(t)) \cdot \begin{pmatrix} 1 \\ \frac{\partial f}{\partial x}(\phi(t)) \end{pmatrix} \right) \\
&= -\left\{ -\frac{\partial^3 f}{\partial x \partial y^2}(\phi(t)) \cdot \frac{\partial^2 f}{\partial y^2}(\phi(t)) + \frac{\partial^3 f}{\partial y^3}(\phi(t)) \cdot \frac{\partial^2 f}{\partial x \partial y}(\phi(t)) \right\} \cdot \begin{pmatrix} 1 \\ \frac{\partial f}{\partial x}(\phi(t)) \end{pmatrix} \\
&\quad - \frac{\partial^2 f}{\partial y^2}(\phi(t)) \cdot \begin{pmatrix} 1 \\ \frac{d}{dt} \left(\frac{\partial f}{\partial x}(\phi(t)) \right) \end{pmatrix} \quad (**).
\end{aligned}$$

If $\frac{d}{dt}(F \circ \phi)(0) = 0$, that is $\frac{\partial^2 f}{\partial y^2}(0, 0) = 0$, then

$$\frac{d^2}{dt^2}(F \circ \phi)(0) = -\frac{\partial^3 f}{\partial y^3}(0,0) \frac{\partial^2 f}{\partial x \partial y}(0,0) \begin{pmatrix} 1 \\ \frac{\partial f}{\partial x}(0,0) \end{pmatrix}$$

Hence

$$\frac{d}{dt}(F \circ \phi)(0) = 0 \text{ and } \frac{d^2}{dt^2}F \circ \phi(0) \neq 0 \iff \frac{\partial^2 f}{\partial y^2}(0,0) = 0, \frac{\partial^2 f}{\partial x \partial y} \neq 0 \text{ and } \frac{\partial^3 f}{\partial y^3}(0,0) \neq 0. \quad \square$$

3.2.5. Examples : (1) The fold (x, y^2) and the cusp $(x, xy - y^3)$ satisfy the conditions in Definition 3.2.1.

(2) *The midpoint locus.*

We recall the notation in [G-B]. Let γ be a parametrization of a smooth unit speed curve, and T its tangent vector. Take two points $\gamma(t_1)$ and $\gamma(t_2)$ and denote two neighbourhoods of these points on γ by γ_1 and γ_2 . The pieces of curves γ_1 and γ_2 are unit speed. Their unit tangent vectors are denoted by T_1 and T_2 respectively, and their curvatures κ_1 and κ_2 . The *midpoint map* is defined as follows,

$$\begin{aligned} m : R^2, 0 &\longrightarrow R^2 \\ (t_1, t_2) &\longmapsto \frac{1}{2}(\gamma_1(t_1) + \gamma_2(t_2)) \end{aligned}$$

The differential of m at (t_1, t_2) is $Dm(t_1, t_2) = \frac{1}{2}(T(t_1), T(t_2))$. The critical set of m is then $\Sigma_m = \{(t_1, t_2) : T_2(t_2) = \pm T_1(t_1)\}$.

The critical set Σ_m is smooth if and only if $\kappa_1(0) \neq 0$ or $\kappa_2(0) \neq 0$. Let assume that $\kappa_2(0) \neq 0$. We can locally parametrize Σ_m by $\phi(t) = (t_1, t_2(t_1))$ with $t_2'(t_1) = \frac{\kappa_1(t_1)}{\kappa_2(t_2(t_1))}$. We have

$$\begin{aligned} \frac{d}{dt}(m \circ \phi)(t_1) &= \frac{1}{2} \left\{ T_1(t_1) + \frac{\kappa_1(t_1)}{\kappa_2(t_2(t_1))} T(t_2(t_1)) \right\} \\ &= \frac{1}{2\kappa_2(t_2(t_1))} \left\{ \kappa_2(t_2(t_1)) T_1(t_1) + \kappa_1(t_1) T_2(t_2(t_1)) \right\} \\ &= \frac{1}{2\kappa_2(t_2(t_1))} \left\{ \kappa_2(t_2(t_1)) \pm \kappa_1(t_1) \right\} T_1(t_1) \end{aligned}$$

To simplify the notation we shall write for example κ_2 for $\kappa_2(t_2(t_1))$. Differentiating once more we obtain

$$\begin{aligned} \frac{d^2}{dt^2}(m \circ \phi)(t_1) &= \frac{d}{dt} \left(\frac{1}{2\kappa_2} (\kappa_2 \pm \kappa_1) T_1 \right) \\ &= \frac{1}{2\kappa_2} \left(\frac{\kappa_1}{\kappa_2} \kappa_2' \pm \kappa_1' \right) T_1 + (\kappa_2 \pm \kappa_1) \frac{d}{dt} \left(\frac{1}{2\kappa_2} T_1 \right) \end{aligned}$$

Hence,

$$\frac{d}{dt}(m \circ \phi)(0) \neq 0 \iff \kappa_2(0) \neq \mp \kappa_1(0)$$

and

$$\frac{d}{dt}(m \circ \phi)(0) = 0 \text{ and } \frac{d^2}{dt^2}(m \circ \phi)(0) \neq 0 \iff \kappa_2(0) = \mp \kappa_1(0) \text{ and } \kappa_2'(0) \neq \kappa_1'(0)$$

By Proposition 3.2.4 the midpoint map m is a fold map at $(0,0)$ if and only if $T_2(0) = \pm T_1(0)$ and $\kappa_2(0) \neq \mp \kappa_1(0)$, and is a cusp map at $(0,0)$ if and only if $T_2(0) = \pm T_1(0)$, $\kappa_2(0) = \mp \kappa_1(0)$ and $\kappa_2'(0) \neq \kappa_1'(0)$.

These conditions are interpreted geometrically by looking at the order of contact of Σ_m and $\ker(Dm(0,0))$ in (figure 3.2.2).

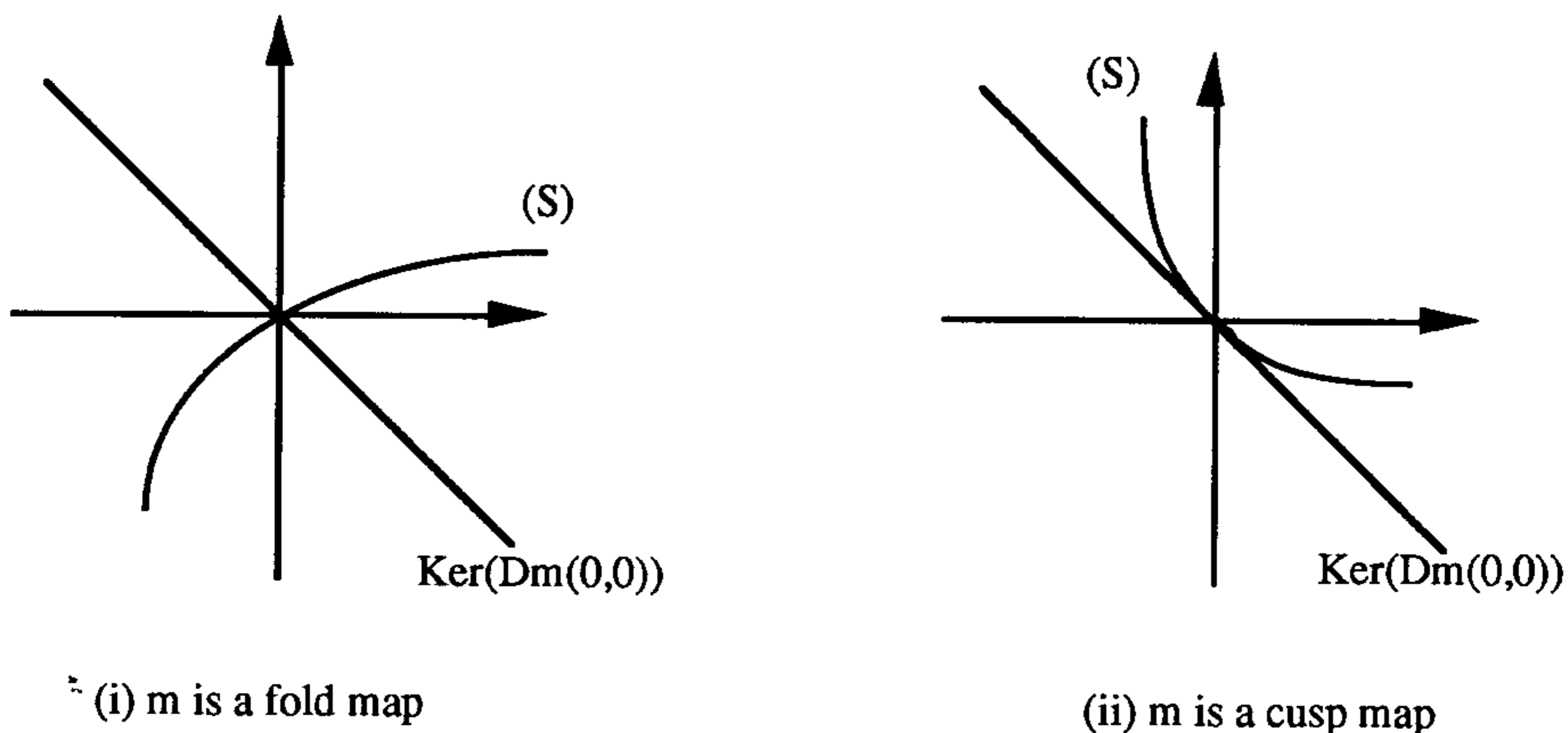

Figure 3.2.2

§3. Recognition of a swallowtail map

A map germ from the plane to the plane is called a swallowtail map if it is \mathcal{A} -equivalent to the germ $(x, xy + y^4)$. Let F as before be of the form $F(x, y) = (x, f(x, y))$. We have the following result. (See [R1] for proof.)

3.3.1. Proposition : *The map F is a swallowtail map if and only if $\frac{\partial^2 f}{\partial y^2}(0,0) = \frac{\partial^3 f}{\partial y^3}(0,0) = 0$, $\frac{\partial^2 f}{\partial x \partial y}(0,0) \neq 0$ and $\frac{\partial^4 f}{\partial y^4}(0,0) \neq 0$. □*

Let ϕ , as in Proposition 3.2.4, be a local parametrization of Σ satisfying $\frac{d}{dt}\phi(t) = (-\frac{\partial^2 f}{\partial y^2}(\phi(t)), \frac{\partial^2 f}{\partial x \partial y}(\phi(t)))$. We shall show that the condition in Proposition 3.3.1 is equivalent to the following.

3.3.2. Proposition : *The map F is a swallowtail map if and only if $\frac{d}{dt}(F \circ \phi)(0) = \frac{d^2}{dt^2}(F \circ \phi)(0) = 0$ and $\frac{d^3}{dt^3}(F \circ \phi)(0) \neq 0$.*

Proof: Proposition 3.2.4 shows that

$$\frac{d}{dt}(F \circ \phi)(0) = \frac{d^2}{dt^2}(F \circ \phi)(0) = 0 \iff \frac{\partial^2 f}{\partial y^2}(0,0) = \frac{\partial^3 f}{\partial y^3}(0,0), \frac{\partial^2 f}{\partial x \partial y}(0,0) = 0$$

Differentiating (**) once more in the proof of Proposition 3.2.4, when $\frac{d}{dt}(F \circ \phi)(0) = \frac{d^2}{dt^2}(F \circ \phi)(0) = 0$, we deduce that

$$\frac{d^3}{dt^3}(F \circ \phi)(0) = -\frac{\partial^4 f}{\partial y^4}(0,0) \cdot \left(\frac{\partial^2 f}{\partial x \partial y}(0,0)\right)^2 \begin{pmatrix} 1 \\ \frac{\partial f}{\partial x}(0,0) \end{pmatrix}$$

Hence $\frac{d}{dt}(F \circ \phi)(0) = \frac{d^2}{dt^2}(F \circ \phi)(0) = 0$, $\frac{d^3}{dt^3}(F \circ \phi)(0) \neq 0$ if and only if $\frac{\partial^2 f}{\partial y^2} = \frac{\partial^3 f}{\partial y^3} = 0$, $\frac{\partial^2 f}{\partial x \partial y} \neq 0$, $\frac{\partial^4 f}{\partial y^4} \neq 0$.

We conclude using Proposition 3.3.1. □

The conditions in Proposition 3.3.2 express the order of contact of the critical set Σ with the line $\text{Ker}(DF(0,0))$. Thus,

3.3.3. Corollary : *A map $F : R^2,0 \rightarrow R^2,0$ of rank 1 at the origin and having locally a smooth critical set is a swallowtail map if and only if its critical set Σ has 3 point-contact with the kernel of $DF(0,0)$ at the origin as in (figure 3.3.1). □*

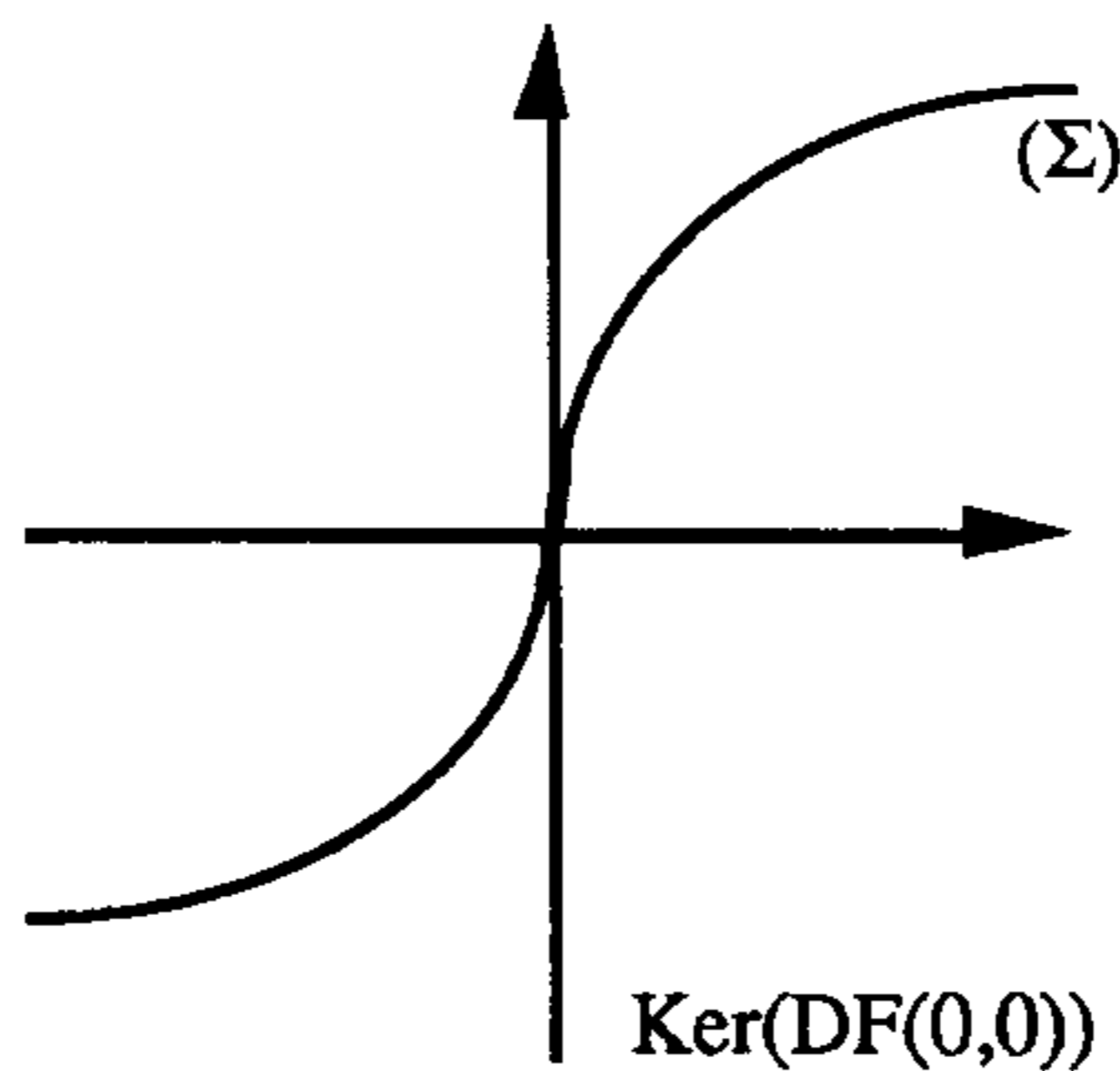

Figure 3.3.1 A swallowtail map

3.3.4. Example : The centre map (Chapter 5).

Recall the notation in Example 3.2.5. Let R^2 be the real plane identified with the complex numbers C . The *central map* C^+ is defined as follows.

$$C^+ : R^2 \longrightarrow C$$

$$(t_1, t_2) \longmapsto \frac{\gamma(t_1)T(t_2) - \gamma(t_2)T(t_1)}{T(t_2) - T(t_1)}$$

The critical set of the map C^+ is

$$\Sigma_{C^+} = \{(t, t) : t \in R\} \cup \{(t_1, t_2) : \kappa(t_1) = \kappa(t_2)\} \cup \{(t_1, t_2) : C^+(t_1, t_2) \in SS\}$$

where SS denotes the symmetry set of the curve γ . Calculations in Chapter 5 show the following.

(1). When Σ_{C^+} is locally $\{(t_1, t_2) : \kappa(t_1) = \kappa(t_2)\}$ at (t_1^0, t_2^0) , the map C^+ is a swallowtail map if and only if $\kappa(t_1^0) = \kappa(t_2^0)$, $\kappa'(t_1^0) = \kappa'(t_2^0)$, $\kappa''(t_1^0) = \kappa''(t_2^0)$ and $\kappa'''(t_1^0) \neq \kappa'''(t_2^0)$ (Proposition 5.3.2 (iii) in Chapter 5).

(2). When Σ_{C^+} is locally $\{(t_1, t_2) : C^+(t_1, t_2) \in SS\}$ at (t_1^0, t_2^0) , it can be parametrized by $\phi : I \longrightarrow R^2$, $\phi(t_1) = (t_1, t_2(t_1))$ with $t_2'(t_1) = -\frac{1 - r\kappa(t_1)}{1 - r\kappa(t_2(t_1))}$, provided that the bitangent circle is not bi-osculating at $\gamma(t_2^0)$. Here r denotes the radius of the bitangent circle to the curve γ . We have

$$\frac{d}{dt}(C^+ \circ \phi)(t_1) = \frac{\partial C^+}{\partial t_1}(t_1, t_2(t_1)) - \frac{1 - r\kappa(t_1)}{1 - r\kappa(t_2(t_1))} \frac{\partial C^+}{\partial t_2}(t_1, t_2(t_1))$$

In the expression for the partial derivatives of the map C^+ in Chapter 5 (in proof of Proposition 5.3.1), it is not hard to see that when $C^+(t_1, t_2)$ is the centre of a bitangent circle we have $\frac{\partial C^+}{\partial t_1}(t_1, t_2) = (1 - r\kappa(t_1)) \frac{T(t_1)T(t_2)}{T(t_1) - T(t_2)}$ and $\frac{\partial C^+}{\partial t_2}(t_1, t_2) = -(1 - r\kappa(t_2)) \frac{T(t_1)T(t_2)}{T(t_1) - T(t_2)}$. It follows that

$$\frac{d}{dt}(C^+ \circ \phi)(t_1) = 2(1 - r\kappa(t_1)) \frac{T(t_1)T(t_2(t_1))}{T(t_1) - T(t_2)}$$

Therefore $\frac{d}{dt}(C^+ \circ \phi)(t_1^0) = 0 \iff r = \frac{1}{\kappa(t_1^0)}$, that is the bitangent circle is osculating at $\gamma(t_1)$. Now,

$$\frac{d}{dt}(C^+ \circ \phi)(t_1^0) = \frac{d^2}{dt^2}(C^+ \circ \phi)(t_1^0) = 0 \iff r = \frac{1}{\kappa(t_1^0)} \text{ and } \kappa'(t_1^0) = 0$$

If $\frac{d^3}{dt^3}(C^+ \circ \phi)(t_1^0) \neq 0$ the bitangent circle to the curve is an A_1A_3 circle, *i.e.*, γ has a vertex at $\gamma(t_1^0)$, the map C^+ is a swallowtail map at (t_1^0, t_2^0) and for a generic 1-parameter families of curves (γ_s) the symmetry set undergoes the swallowtail transition. But in [B-G3] the generic transition on the symmetry set is the one shown

in (figure 3.3.2). The symmetry set at an A_1A_3 consists of two branches. The first branch is the centres of circles bitangent to the curve at points in small neighbourhoods of $\gamma(t_1^0)$ and $\gamma(t_2^0)$, and the second branch is the centres of bitangent circles to the curve in a neighbourhood of the vertex $\gamma(t_1^0)$. The map C^+ does not pick up the points on the second branch on the symmetry set (figure 3.3.2). The method described in [B-G3] is more efficient to study the symmetry set!

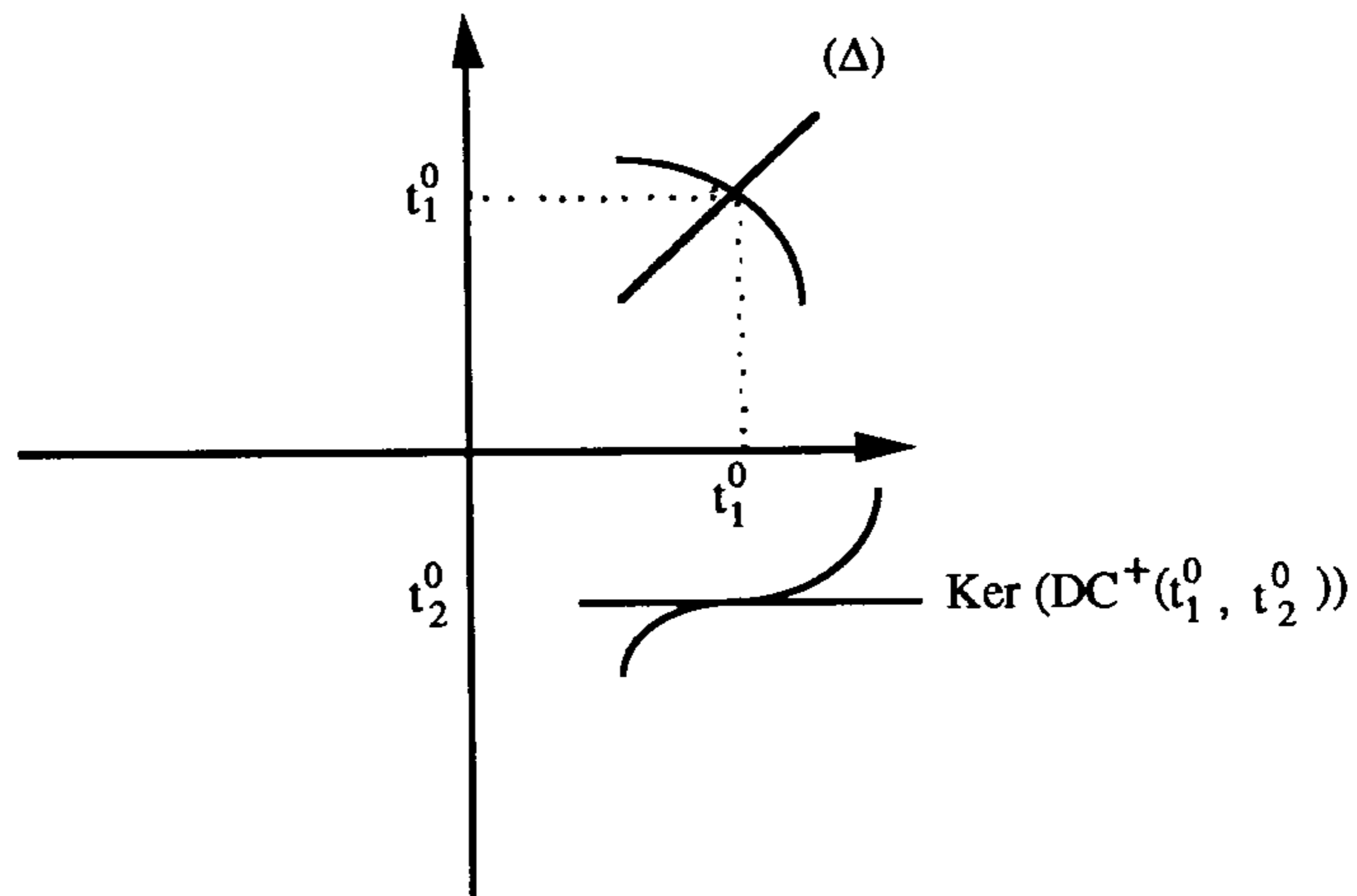

The critical set of C^+ has three components at an A_1A_3 point

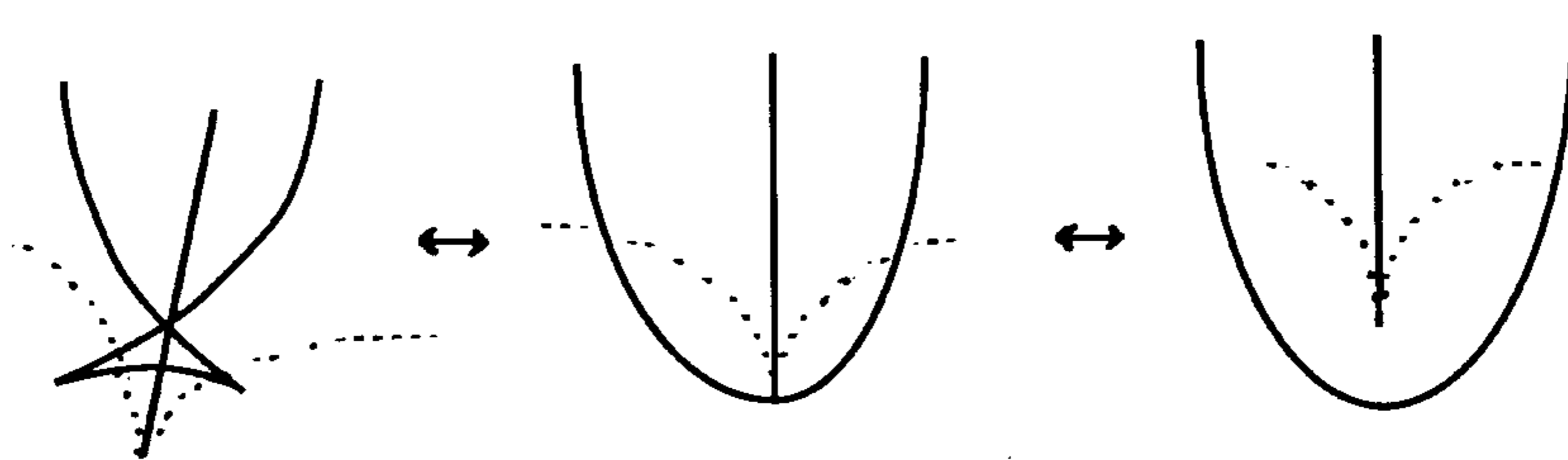

$A_1 A_3$ transition on Symmetry Set
(The dotted curve is the evolute)

Figure 3.3.2

3.3.5. Remark : We are tempted to generalize the results in Corollary 3.3.3 and say that any finitely \mathcal{A} -determined germ F from the plane to the plane of rank ≥ 1 and of smooth critical set is completely determined by the order of contact of its critical set with $\ker(DF(0,0))$. One quickly realizes that this is not true by considering the germs $(x, xy + y^5)$ and $(x, xy + y^5 \pm y^7)$. The critical sets of these two germs have order of contact 4 with the kernel line of their differential maps at the origin. They are both 7- \mathcal{A} -determined but they are not \mathcal{A} -equivalent. An algebraic condition can be added to the order of contact to distinguish between the two germs and one obtains the following.

3.3.6. Proposition : Let $F(x, y) = (x, f(x, y))$ with a smooth critical set. Then F is equivalent to $(x, xy + y^5 \pm y^7)$ [resp. $(x, xy + y^5)$] if and only if its critical set Σ has 4-point contact with $\text{Ker}(DF(0, 0))$ and $\frac{\partial^7 f}{\partial y^7}(0, 0) \neq 0$ [resp. $\frac{\partial^7 f}{\partial y^7}(0, 0) = 0$]. \square

The proof follows the same way as that of Proposition 3.3.2.

§4. Recognition of lips/beaks map

The normal form of a lips/beaks map is $(x, x^2y \pm y^3)$. The critical set is no longer smooth, it consists of an isolated point for $(x, x^2y + y^3)$ and a node for $(x, x^2y - y^3)$.

Let F be as before of the form $F(x, y) = (x, f(x, y))$. In Rieger's classification [R1], the condition for F to be a "lips/beaks" maps is the following.

3.4.1. Proposition : The map F is a lips/beaks map if and only if $\frac{\partial^2 f}{\partial y^2}(0, 0) = \frac{\partial^2 f}{\partial x \partial y}(0, 0)$, $\frac{\partial^3 f}{\partial y^3} \neq 0$ and $(\frac{\partial^3 f}{\partial x \partial y^2})^2(0, 0) - \frac{\partial^3 f}{\partial x^2 \partial y}(0, 0) \cdot \frac{\partial^3 f}{\partial y^3} \neq 0$. \square

We give an equivalent geometric condition to that above.

3.4.2. Proposition : The germ $\frac{\partial f}{\partial y} : R^2, (0, 0) \rightarrow R$ is a germ of a Morse function if and only if $\frac{\partial^2 f}{\partial y^2}(0, 0) = \frac{\partial^2 f}{\partial x \partial y}(0, 0) = 0$ and $(\frac{\partial^3 f}{\partial x \partial y^2})^2(0, 0) - \frac{\partial^3 f}{\partial x^2 \partial y}(0, 0) \cdot \frac{\partial^3 f}{\partial y^3} \neq 0$.

Proof : The proof follows immediately by looking to the Taylor expansion of $\frac{\partial f}{\partial y}$ in a neighbourhood of the origin,

$$\begin{aligned} \frac{\partial f}{\partial y}(x, y) &= \frac{\partial^2 f}{\partial x \partial y}(0, 0) \cdot x + \frac{\partial^2 f}{\partial y^2}(0, 0) \cdot y + \\ &\quad \frac{1}{2} \left\{ \frac{\partial^3 f}{\partial x^2 \partial y}(0, 0) \cdot x^2 + 2 \frac{\partial^3 f}{\partial x \partial y^2}(0, 0) \cdot xy + \frac{\partial^3 f}{\partial y^3} \cdot y^2 \right\} + O_3(x, y) \end{aligned}$$

\square

3.4.3. Lemma : Let F and G two A -equivalent germs. Then the critical set of F is the zero set of a Morse function if and only if the critical set of G is the zero set of a Morse function.

Proof : Write $G = k \circ F \circ h$. From the proof of Lemma 6.1.1 (ii) $\Sigma_G = h(\Sigma_F)$. If $\Sigma_F = f^{-1}(0)$ with f a Morse function, then $f \circ h$ is a Morse function and $\Sigma_G = (f \circ h)^{-1}(0)$. \square

3.4.4. Corollary : *Let G be an equivalent germ to $F(x, y) = (x, f(x, y))$. If $\frac{\partial^3 f}{\partial y^3}(0, 0) \neq 0$, then G is a Lips/beaks map if and only if its critical set is the zero set of a Morse function.* \square

3.4.5. Example : The Corollary 3.4.4 is a big help in finding the generic transitions on 1-parameter families of Rotational Symmetry Sets.

At a point (t_1^0, t_2^0) where the critical set of the central map C^+ is locally $\Sigma = \{(t_1, t_2) : \kappa(t_1) = \kappa(t_2)\}$ is the zero set of the function $K(t_1, t_2) = \kappa(t_2) - \kappa(t_1)$. The Taylor expansion of K is $K(t_1, t_2) = \kappa'(t_2^0).t_2 - \kappa'(t_1^0).t_1 + \frac{1}{2}(\kappa''(t_2^0).t_2^2 - \kappa''(t_1^0)t_1^2) + O_3(t_1, t_2)$.

The function K is a germ of a Morse function if and only if $\kappa'(t_1^0) = \kappa'(t_2^0) = 0$ and $\kappa''(t_1^0).\kappa''(t_2^0) \neq 0$.

If we change coordinates in the source and target and write the map C^+ of the form $(t_1, f(t_1, t_2))$, then the condition $\frac{\partial^3 f}{\partial t_2^3}(0, 0) = 0$ is a condition on the third derivative of C^+ and depends on $\kappa(t_1^0), \kappa'(t_1^0), \kappa''(t_1^0)$ and $\kappa'''(t_1^0)$. If we denote this condition by $R(\kappa(t_1^0), \kappa'(t_1^0), \kappa''(t_1^0)) = 0$ then at (t_1^0, t_2^0) we have the following.

$$\kappa(t_1^0) = \kappa(t_2^0)$$

$$\kappa'(t_1^0) = \kappa'(t_2^0) = 0$$

$$R(\kappa(t_1^0), \kappa'(t_1^0), \kappa''(t_1^0)) = 0$$

This not generic for 1-parameter families of curves. Therefore for generic curves, the central map is a Lips/beaks map if and only if $\kappa'(t_1^0) = \kappa'(t_2^0) = 0$ and $\kappa''(t_1^0).\kappa''(t_2^0) \neq 0$.

Chapter 4

Duals of Symmetry Sets of Plane Curves

§1. Introduction

The local reflectional symmetry of plane curves has been studied in a number of articles [Bra], [B-G3], [B-G-Gi], [G], [G-B], [G-T]. The basic idea is to consider a smooth parametrized curve $\gamma : I \rightarrow R^2$ where I is an open interval of R or $I = S^1$. We normally assume γ is an embedding. We look for pairs of parameter values (t_1, t_2) for which there is some line ℓ with reflexion in ℓ taking $\gamma(t_1)$ and its tangent line to $\gamma(t_2)$ and its tangent line (figure 4.1.1). Thus ℓ is an “infinitesimal axis of symmetry” for γ .

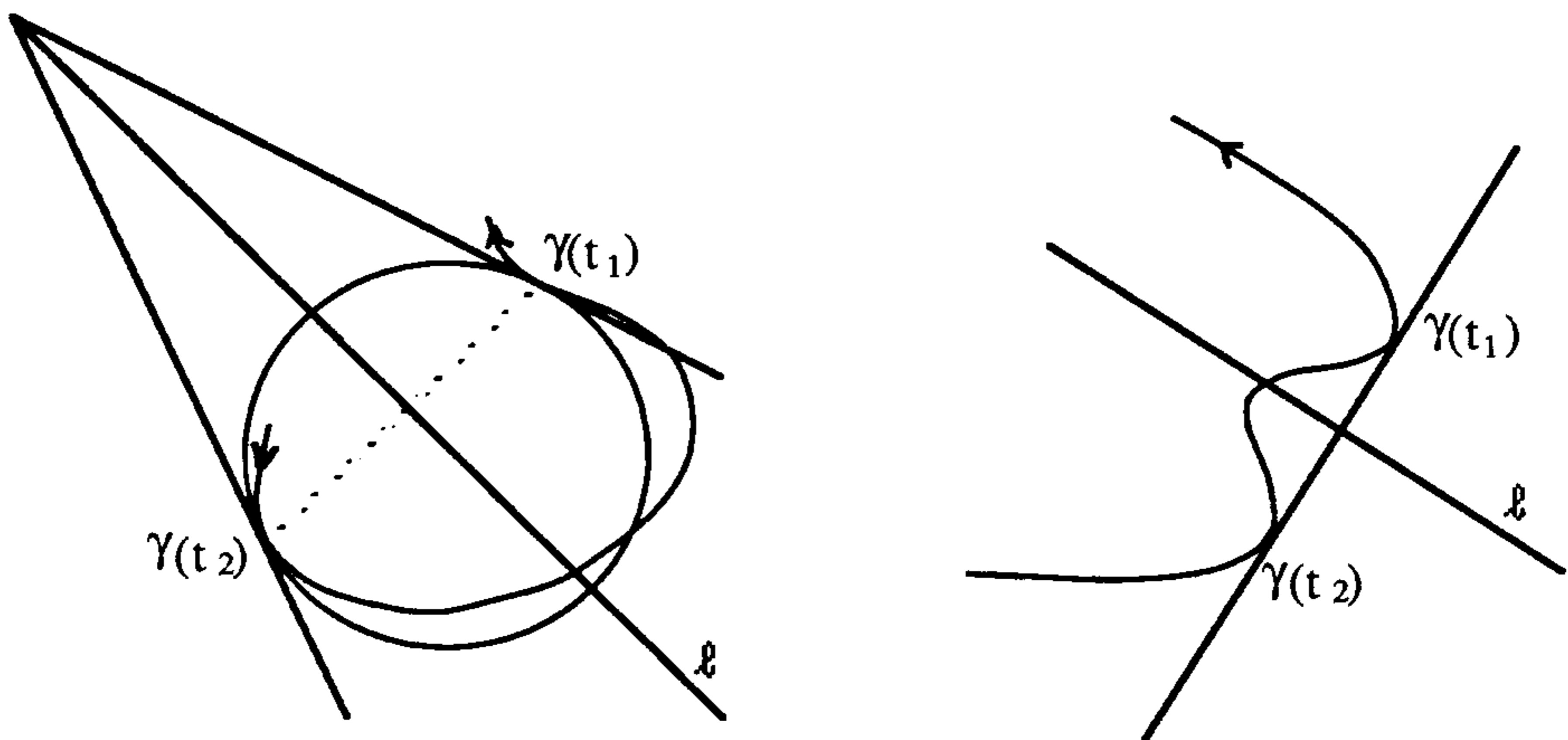

Figure 4.1.1

This is equivalent to looking for bitangent circles (or exceptionally, bitangent lines -see figure 4.1.1). We can capture information about this reflexional symmetry in several ways. Here are two:

(1) Consider the locus of centres of bitangent circles. This gives the *symmetry set* (SS) of the curve γ .

(2) Consider the locus of lines ℓ as a set in the dual plane. This gives the dual of the symmetry set (for ℓ in fact is always tangent to the symmetry set at the centre of the circle).

Some information on the symmetry set can be obtained by direct arguments [G-B] but by far the most fruitful approach is to regard it as part of the *full bifurcation set* of the family of the distance-squared functions on γ [B-G3]. That is, we consider the family $F : I \times R^2 \rightarrow R$ given by $F(t, x) = \|\gamma(t) - x\|^2$, and define the full bifurcation set

$$B(F) = \{x \in \mathbf{R}^2 : F(-, x) \text{ has a degenerate singularity at some } t \\ \text{or two singularities at } t_1, t_2 \text{ with } F(t_1, x) = F(t_2, x)\}$$

This is precisely the union of the evolute E and the symmetry set SS of γ :
 $B(F) = E \cup SS$.

This situation is ideal in the sense it enables us to apply the theory of versal unfoldings, normal forms etc to the structure of the symmetry set [B-G3].

Given a curve in the plane, at each point there is a tangent line (or several tangent lines). Each tangent line is represented by a point in the dual plane and the set of all these points is called the dual curve. An inflexion on the curve corresponds to a cusp on the dual curve and vice-versa. When the original curve is smooth and generic the dual has the same singularities as generic wave fronts. It also has the same transitions as the propagations of wave fronts when considering generic deformations of the curve. (See [A4] ch.8 for an illustration of these.)

However, the duals of symmetry sets of generic plane curves and families of such curves cannot be deduced from these results; for example the symmetry set in the case of a “bi-osculating circle” (a circle osculating γ at two points) is either an isolated point or two cusps with the same origin [B-G3, ex.4.4].

In this chapter we explore the dual of the symmetry set of a plane curve and of 1-parameter families of such by two methods. The first, suggested by J.W.Bruce, identifies it as a bifurcation set and the second identifies it as a discriminant: the set of critical values of a map. In both cases we can again apply standard techniques of singularity theory. The second method brings out the connexion with maps $R^2 \rightarrow R^2$ symmetric under reflexion in a line, studied in [B-G4].

In section 2 we use the first method to produce the list of all generic transitions on 1-parameter families of duals of SS . In section 3 we describe the second method. In section 4 we give the \mathcal{A} -classification of bi-germs of maps $R \rightarrow R^2$ which is needed to compute the bifurcation sets in section 2.

§2. The dual of the symmetry set as a bifurcation set

For a smooth unit speed curve γ with a unit tangent vector T , the circles whose centres give the symmetry set are tangent to the curve at two different places or have higher contact with the curve at a single point (figure 4.2.1).

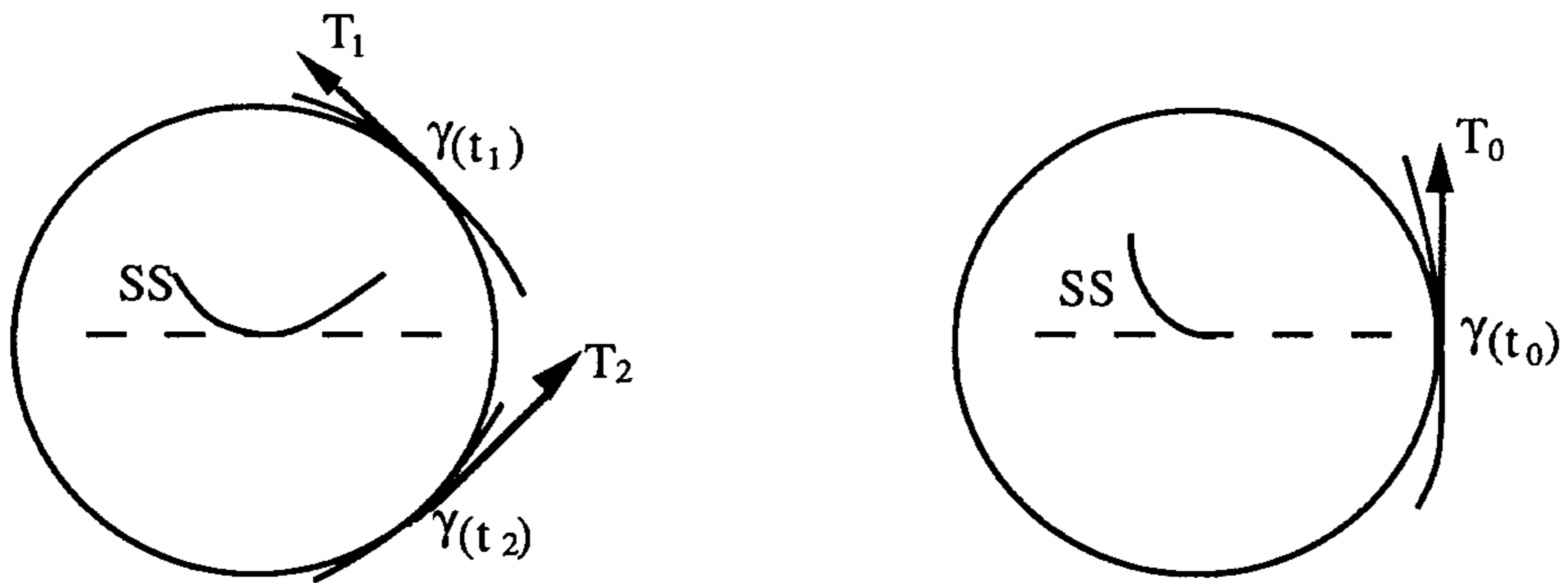

Figure 4.2.1

The tangent to the symmetry set in the first case has the direction of $T_2 - T_1$ (figure 4.2.1, right). When the circle has exactly 4-point contact with the curve the symmetry set has an end point and the (one-sided) tangent line has the direction of the normal to the curve (figure 4.2.1, left). In both cases the tangent line to the symmetry set is an infinitesimal axis of symmetry to the curve (see §1). If the curve γ is locally folded up, *i.e.*, taken by the map (x, y^2) in the coordinate system with the x-axis the tangent line to the symmetry set and the y-axis the normal to it, the result is two tangential pieces of curve or a single singular curve (figure 4.2.2). These are unstable when considered as bi-germs or germs $\mathbf{R} \rightarrow \mathbf{R}^2$. Thus each line ℓ in the plane can be chosen as an x-axis, and the map $\mathbf{R}^2 \rightarrow \mathbf{R}^2$ corresponding to $(x, y) \mapsto (x, y^2)$ when $\ell = x$ -axis can be applied to γ . The dual of the symmetry set consists of those ℓ giving unstable germs or bi-germs.



Figure 4.2.2

It is easy to visualize the unstable lines in the following example. Let $\gamma(y) = (y^2 + y^3, y)$. The reflexion in the x-axis takes γ to $(y^2 + y^3, y^2)$ which is a cusp. When we move the axis of reflexion parallel to the x-axis and reflect γ with respect to the line $y = u$, the resulting curve is $(y^2 + y^3, (y - u)^2)$. The germ $(y^2 + y^3, (y - u)^2)$ is a versal unfolding of the cusp.

Let L be the set of all oriented lines in the plane. There is a 1-1 correspondence between L and $S^1 \times \mathbf{R}$ since each line is the set of points x satisfying $x \cdot u = \lambda$ for some $(u, \lambda) \in S^1 \times \mathbf{R}$. Suppose we are given a smooth curve γ and a line $\ell = (u, \lambda)$ (figure 4.2.3). Let $p_{(u, \lambda)}(t)$ and $d_{(u, \lambda)}(t)$ be the orthogonal projection of $\gamma(t)$ on ℓ and the distance of $\gamma(t)$ to ℓ respectively. It is easy to check that :

$$d_{(u, \lambda)}(t) = \lambda - \gamma(t) \cdot u$$

$$p_{(u,\lambda)}(t) = \gamma(t) + (\lambda - \gamma(t) \cdot u)u,$$

where \cdot denotes the scalar product in \mathbf{R}^2 .

Consider the following map:

$$F : \mathbf{R} \times S^1 \times \mathbf{R} \longrightarrow \mathbf{R}^2$$

$$(t, u, \lambda) \longmapsto p_{(u,\lambda)}(t) + d_{(u,\lambda)}^2(t) \cdot u$$

More explicitly : $F(t, u, \lambda) = \gamma(t) + (\lambda - \gamma(t) \cdot u)[1 + (\lambda - \gamma(t) \cdot u)]u$. For each (u, λ) , $F_{(u,\lambda)}$ (where $F_{(u,\lambda)}(t) = F(t, u, \lambda)$) is the restriction of the fold map (x, y^2) to the curve γ in the coordinate system with the x-axis the line ℓ and the y-axis a line parallel to u .

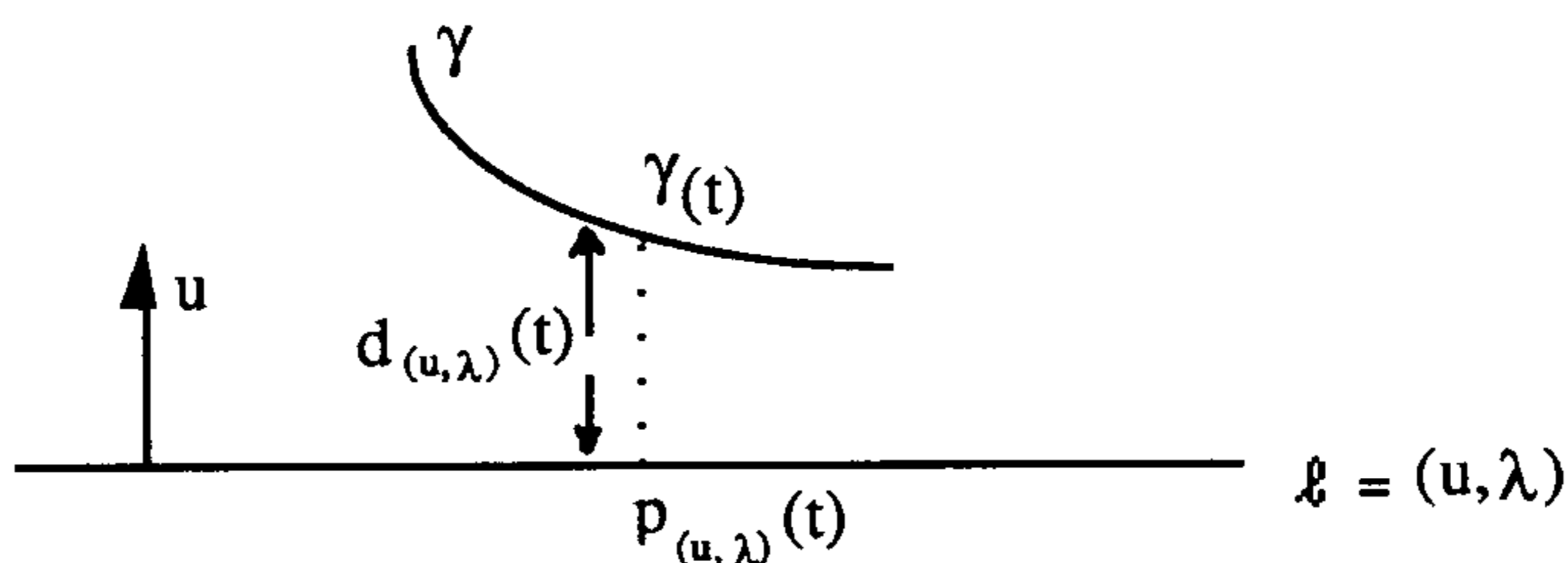

Figure 4.2.3

5.2.1. Definition : *The bifurcation set of the map F , denoted by $B(F)$, is the set of points (u, λ) where $F_{(u,\lambda)}$ is locally unstable as a map $\mathbf{R} \longrightarrow \mathbf{R}^2$, with respect to smooth changes of coordinates in source and target.*

Geometrically $F_{(u,\lambda)}$ has a non stable singularity if its vector derivative $F'_{(u,\lambda)}(t_0)$ is zero, that is $F_{(u,\lambda)}$ is a reflexion with respect to the line (u, λ) passing through $\gamma(t_0)$, or there exist two points t_1, t_2 with neighbourhoods mapped by $F_{(u,\lambda)}$ to two tangential pieces of curves, *i.e.*, $F_{(u,\lambda)}(t_1) = F_{(u,\lambda)}(t_2)$ and $F'_{(u,\lambda)}(t_1), F'_{(u,\lambda)}(t_2)$ are linearly dependent (figure 4.2.2).

In all what follows we assume that the tangent vectors to the curve γ at two different points are not parallel. The following assertion derives naturally from the above definition.

5.2.2. Theorem : *The bifurcation set of the map F is locally the union of the dual of the symmetry set and the dual of the evolute of the curve γ .*

Proof: From definition 4.2.1

$$\begin{aligned}
B(F) &= \{(u, \lambda) / \exists t : F'_{(u, \lambda)}(t) = 0 \text{ or} \\
&\quad \exists t_1, t_2 : F_{(u, \lambda)}(t_1) = F_{(u, \lambda)}(t_2) \text{ and } F'_{(u, \lambda)}(t_1), F'_{(u, \lambda)}(t_2) \text{ linearly dependent}\} \\
&= \{(u, \lambda) / \exists t : F'_{(u, \lambda)}(t) = 0\} \cup \\
&\quad \{(u, \lambda) / \exists t_1, t_2 : F_{(u, \lambda)}(t_1) = F_{(u, \lambda)}(t_2) \text{ and } F'_{(u, \lambda)}(t_1) // F'_{(u, \lambda)}(t_2)\}
\end{aligned}$$

We seek a geometric interpretation for the components of $B(F)$. We have $F_{(u, \lambda)}(t) = \gamma(t) + (\lambda - \gamma(t).u)[1 + (\lambda - \gamma(t).u)]u$, so

$$\begin{aligned}
F'_{(u, \lambda)}(t) = 0 &\iff \frac{\partial}{\partial t}(\gamma(t) + (\lambda - \gamma(t).u)[1 + (\lambda - \gamma(t).u)]u) = 0 \\
&\iff T(t) - [T(t).u + 2T(t).u(\lambda - \gamma(t).u)]u = 0 \\
&\iff T(t) = [T(t).u + 2T(t).u(\lambda - \gamma(t).u)]u
\end{aligned}$$

The vectors $T(t)$ and u are unit vectors, so $T(t) = \pm u$ and $T(t).u(\lambda - \gamma(t).u) = 0$, equivalently $\lambda - \gamma(t).u = 0$. Replacing u by $\pm T(t)$ yields $\lambda = \pm \gamma(t).T(t)$, and

$$\{(u, \lambda) / \exists t : F'_{(u, \lambda)}(t) = 0\} = \{(\pm T(t), \pm \gamma(t).T(t))\}$$

The points $(T(t), \gamma(t).T(t))$ and $(-T(t), -\gamma(t).T(t))$ in L represent the normal line to the curve γ at the point $\gamma(t)$. The set of all normal lines to the curve γ is the dual of the evolute of γ .

For the second component of $B(F)$ we have

(i).

$$\begin{aligned}
F_{(u, \lambda)}(t_1) &= F_{(u, \lambda)}(t_2) \\
&\iff \\
\gamma(t_1) + (\lambda - \gamma(t_1).u)[1 + (\lambda - \gamma(t_1).u)]u &= \gamma(t_2) + (\lambda - \gamma(t_2).u)[1 + (\lambda - \gamma(t_2).u)]u \\
&\iff \\
\gamma(t_1) - \gamma(t_2) - [(\gamma(t_1) - \gamma(t_2)).u + (2\lambda - (\gamma(t_1) + \gamma(t_2)).u)(\gamma(t_1) - \gamma(t_2)).u]u &= 0
\end{aligned}$$

The vectors $\gamma(t_1) - \gamma(t_2)$ and u are then parallel, and since u is unit, we can write $\gamma(t_1) - \gamma(t_2) = [(\gamma(t_1) - \gamma(t_2)).u]u$ (with $(\gamma(t_1) - \gamma(t_2)).u \neq 0$). Substituting this equality in the above equation yields

$$2\lambda - (\gamma(t_1) + \gamma(t_2)).u = 0 \iff \lambda = \frac{1}{2}(\gamma(t_1) + \gamma(t_2)).u$$

Thus

$$F_{(u, \lambda)}(t_1) = F_{(u, \lambda)}(t_2) \iff \begin{cases} u = \pm \frac{\gamma(t_1) - \gamma(t_2)}{\|\gamma(t_1) - \gamma(t_2)\|} & \text{and} \\ \lambda = \frac{1}{2}(\gamma(t_1) + \gamma(t_2)).u \end{cases}$$

(ii). The vectors $F'_{(u,\lambda)}(t_1), F'_{(u,\lambda)}(t_2)$ are linearly dependent. We have

$$\begin{aligned} F'_{(u,\lambda)}(t_1) &= T(t_1) - [T(t_1).u + 2T(t_1).u(\lambda - \gamma(t_1).u)]u \\ F'_{(u,\lambda)}(t_2) &= T(t_2) - [T(t_2).u + 2T(t_2).u(\lambda - \gamma(t_2).u)]u \end{aligned}$$

Replacing λ by its value in (i) gives

$$\begin{aligned} F'_{(u,\lambda)}(t_1) &= T(t_1) - T(t_1).u[1 - (\gamma(t_1) - \gamma(t_2)).u]u \\ F'_{(u,\lambda)}(t_2) &= T(t_2) - T(t_2).u[1 + (\gamma(t_1) - \gamma(t_2)).u]u \end{aligned}$$

Let v be a unit vector orthogonal to u , and write $T(t_1)$ and $T(t_2)$ in the coordinates system with respect to the basis $\{u, v\}$. We have $T(t_1) = (T(t_1).u)u + (T(t_1).v)v$ and $T(t_2) = (T(t_2).u)u + (T(t_2).v)v$. The expressions for $F'_{(u,\lambda)}(t_1)$ and $F'_{(u,\lambda)}(t_2)$ become

$$\begin{aligned} F'_{(u,\lambda)}(t_1) &= [T(t_1).u(\gamma(t_1) - \gamma(t_2)).u]u + [T(t_1).v]v \\ F'_{(u,\lambda)}(t_2) &= -[T(t_2).u(\gamma(t_1) - \gamma(t_2)).u]u + [T(t_2).v]v \end{aligned}$$

These vectors are linearly dependent if and only if the matrix

$$\begin{pmatrix} T(t_1).u(\gamma(t_1) - \gamma(t_2)).u & T(t_1).v \\ -T(t_2).u(\gamma(t_1) - \gamma(t_2)).u & T(t_2).v \end{pmatrix}$$

has zero determinant, that is $[T(t_1).v][T(t_2).u] + [T(t_1).u][T(t_2).v] = 0$. Geometrically this amounts to saying that $T(t_2)$ and $-[T(t_1).u]u + [T(t_1).v]v$ are parallel. Since they are both unit, $T(t_2) = \pm(-[T(t_1).u]u + [T(t_1).v]v)$. This relation is equivalent to $(T(t_1) \pm T(t_2)).u = 0$ provided $T(t_1) \neq \pm T(t_2)$. But $u = \pm \frac{\gamma(t_1) - \gamma(t_2)}{\|\gamma(t_1) - \gamma(t_2)\|}$ in (i), hence

$$F'_{(u,\lambda)}(t_1) // F'_{(u,\lambda)}(t_2) \iff (T(t_1) \pm T(t_2)).u \cdot (\gamma(t_1) - \gamma(t_2)) = 0$$

The equation $(T(t_1) \pm T(t_2)).u \cdot (\gamma(t_1) - \gamma(t_2)) = 0$ is the necessary and sufficient condition for the existence of a bitangent circle to the curve γ at $\gamma(t_1)$ and $\gamma(t_2)$. The tangent to the symmetry set at the corresponding point is the line with direction the vector $T(t_1) \pm T(t_2)$ and which passes through the point $\frac{1}{2}(\gamma(t_1) - \gamma(t_2))$ [G-B]. Such a line has a unit normal vector $u = \pm \frac{\gamma(t_1) - \gamma(t_2)}{\|\gamma(t_1) - \gamma(t_2)\|}$ and is represented in L by the point $(\pm \frac{\gamma(t_1) - \gamma(t_2)}{\|\gamma(t_1) - \gamma(t_2)\|}, \pm \frac{1}{2}(\gamma(t_1) - \gamma(t_2)) \frac{\gamma(t_1) - \gamma(t_2)}{\|\gamma(t_1) - \gamma(t_2)\|})$. Now

$$\begin{cases} F_{(u,\lambda)}(t_1) = F_{(u,\lambda)}(t_2), \\ F'_{(u,\lambda)}(t_1) // F'_{(u,\lambda)}(t_2) \end{cases} \iff \begin{cases} u = \pm \frac{\gamma(t_1) - \gamma(t_2)}{\|\gamma(t_1) - \gamma(t_2)\|}, \\ \lambda = \pm \frac{1}{2}(\gamma(t_1) - \gamma(t_2)) \frac{\gamma(t_1) - \gamma(t_2)}{\|\gamma(t_1) - \gamma(t_2)\|} \quad \text{and} \\ (T(t_1) \pm T(t_2))_2 \cdot (\gamma(t_1) - \gamma(t_2)) = 0 \end{cases}$$

$$\iff \begin{cases} \exists \text{ a bitangent circle to } \gamma \text{ at } \gamma(t_1) \text{ and } \gamma(t_2) \text{ and} \\ (u, \lambda) \text{ is the tangent line to the Symmetry Set} \\ \text{at the corresponding point.} \end{cases}$$

Therefore the second component of $B(F)$ is the dual of the symmetry set, and

$$B(F) = \text{Dual of the Evolute} \cup \text{Dual of the Symmetry Set}$$

□

Following the notation in [B-G3] the cases of interest for the study of the duals of symmetry sets and their 1-parameter families are : inflexion and higher inflexion on the symmetry set, A_2^2 , A_3 and the A_4 . (Here A_k is Arnold's notation for the singularity of the distance-squared function, and A_2^2 refers to two A_2 singularities at the same level (bitangent circle). Thus A_3 stands for a vertex, and A_4 for a higher vertex, on γ .)

In order to study the singularities occurring in the duals of symmetry sets one has to consider the bi-germ (F_1, F_2) associated to the two pieces of curves γ_1 and γ_2 which locally give the symmetry set (figure 4.2.1, right) or the uni-germ F associated to a single piece of curve γ with a vertex (figure 4.2.1, left). For generic 1-parameter families of curves (γ_s) we consider the 'big' family of germs (denoted also by F):

$$F : R \times S^1 \times R \times R \longrightarrow R^2$$

$$(t, u, \lambda, s) \longmapsto F_s(t, u, \lambda)$$

and the 'big' bifurcation set $B(F)$. We shall use the unfolding theory to describe the generic transitions on 1-parameter families of duals of SS . This problem requires us to deal with the three following points.

(1). Firstly, we require the normal forms of singularities of bi-germs and single germs of functions $R \longrightarrow R^2$ of codimensions less than 3 when allowing smooth changes of coordinates in the source and target, and the description of the bifurcation sets of their versal unfoldings. (This is done in §4.) Secondly, we need to recognize the singularity type of $F_0 = F|_{R \times 0 \times 0 \times 0}$ as a bi-germ (for an A_2^2 , inflexion or higher inflexion on SS) or a single germ (for the A_3, A_4 cases).

(2). We need to show that, for generic families of curves γ^s , the family F is a

versal unfolding for the singularity of F_0 . Its bifurcation set is then diffeomorphic to that of the bifurcation set of the normal form of the singularity of F_0 .

(3). We need to consider generic functions on the big bifurcation set of the unfolding of the normal form of the singularity F_0 , and recover the individual bifurcation sets by taking the intersection of the (big) bifurcation set with the fibres of these functions [A2],[B1],[B-G3].

We shall deal with each case separately. But first

5.2.3. A word on genericity

The notion of genericity and transversality for plane and space curves is beautifully explained in the book “Curves and singularities” by J. W. Bruce and P. J. Giblin [B-G1] chapters 8 and 9. We give a summary on how to check if a property holds generically and refer to [B-G1] for the details.

Let γ be a plane (smooth and embedded) curve. At each point $\gamma(t)$ we write γ locally in its Monge normal form, *i.e.*, as a graph of a function f_t (with $f_t(0) = f'_t(0) = 0$) and associate to f_t its Taylor polynomial of degree k at the origin. If we write $(a_2(t), \dots, a_k(t))$ for the coefficients of this polynomial, we obtain a map $\mu_\gamma : I \subset \mathbb{R} \longrightarrow \mathbb{R}^{k-1}$ with $\mu_\gamma(t) = (a_2(t), \dots, a_k(t))$. The polynomial $(a_2(t), \dots, a_k(t))$ carries the infinitesimal properties of the curve γ , and any property of the curve can be interpreted through this polynomial.

A property P is said to be generic if it is satisfied in an open and dense set in a finite dimensional space of deformations of curves. (See [B-G1] for a rigorous definition.)

To prove that a property P is generic we consider a family $\mu : I \times U \longrightarrow \mathbb{R}^{k-1}$ (where U is an open neighbourhood of the origin in the finite dimensional set of k -jets of diffeomorphisms from the plane to the plane) with $\mu(t, \psi) = \mu_{\psi \circ \gamma}(t)$, and show that the map μ is transverse to the manifold Y of points in \mathbb{R}^{k-1} which do not satisfy P . For example if $k = 4$ and Y is defined by two equations in \mathbb{R}^3 , that is Y is of dimension 1, then generically the curve $\mu_\gamma(I)$ misses Y . If we consider 1-parameter families of curves γ_s and write $\gamma(t, s) = \gamma_s(t)$, then generically the surface $\mu_\gamma(I \times \mathbb{R})$ meets Y transversally in isolated points. If we add another equation to Y it becomes of dimension 0 and the surface $\mu_\gamma(I \times \mathbb{R})$ will generically miss Y .

In what follows we shall not find the explicit genericity conditions, but adopt a more informal approach by “counting conditions”.

The dual of an A_2^2

An A_2^2 singularity occurs on the SS when the bitangent circle is biosculating. It can happen at isolated points on 1-parameter families of curves γ .

To handle the calculations, we choose a local coordinate system and suppose that the centre of the biosculating circle is on the x -axis and its points of contact with the curve are on the y -axis symmetric with respect to the origin.

As we are dealing with local properties of the SS we denote by γ_1 and γ_2 two neighbourhoods on the curve γ at the biosculating points. We choose orientations on γ_1 and γ_2 that are shown on (figure 4.2.4), and suppose that the two curves are given as graphs of smooth functions $y_1(x) = q_1 + a_1x + b_1x^2 + c_1x^3 + O_1(x^4)$ for γ_1 and $y_2(x) = q_2 + a_2x + b_2x^2 + c_2x^3 + O_2(x^4)$ for γ_2 .

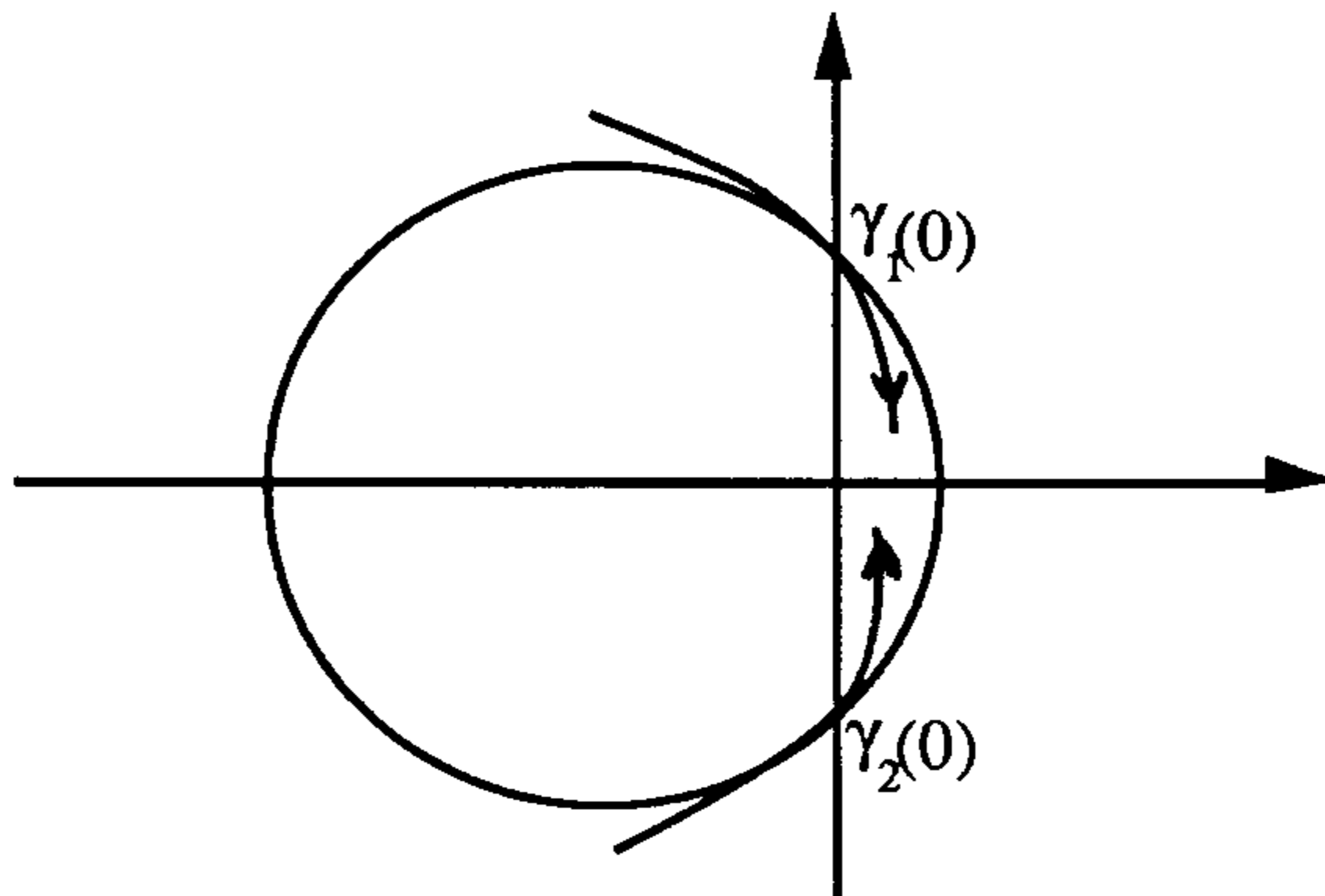

Figure 4.2.4

We consider a 1-parameter family of curves γ_i^s with $\gamma_i^0 = \gamma_i$ $i = 1, 2$, and suppose that the coefficients q_i, a_i, b_i, \dots etc, $i = 1, 2$ in the expressions of these curves as graphs of functions, are smooth functions of the parameter s . The hypothesis on the biosculating circle induces the following conditions on these coefficients.

- (i). $q_2(0) = -q_1(0)$
- (ii). $a_2(0) = -a_1(0)$
- (iii). $\kappa_2(0) = -\kappa_1(0) \iff \frac{2b_2(0)}{(1+a_2^2(0))^{\frac{3}{2}}} = -\frac{2b_1(0)}{(1+a_1^2(0))^{\frac{3}{2}}} \iff b_2(0) = -b_1(0)$

The normal vector to the curve γ_1^0 at the point $(0, q_1(0))$ is $N = \left(-\frac{a_1(0)}{\sqrt{1+a_1^2(0)}}, \frac{1}{\sqrt{1+a_1^2(0)}}\right)$ and the radius of curvature is $r = \frac{(1+a_1^2(0))^{\frac{3}{2}}}{2b_1(0)}$. The centre of the biosculating circle lies on the x -axis if and only if the point

$(0, q_1(0)) + \frac{(1 + a_1^2(0))^{\frac{3}{2}}}{2b_1(0)} \left(-\frac{a_1(0)}{\sqrt{1 + a_1^2(0)}}, \frac{1}{\sqrt{1 + a_1^2(0)}} \right)$ has zero y -component.

That is,

$$(iv). \quad a_1^2(0) + 2q_1(0)b_1(0) + 1 = 0$$

We can identify locally the set L of all lines in the plane with R^2 as follows: $L = \{(\theta, \lambda) : u = (\sin\theta, \cos\theta), \theta, \lambda \in R\}$. We then have for each piece of curve γ_i a germ of the big family

$$F_i : R \times R^2 \times R \longrightarrow R^2$$

$$(t, u, \lambda, s) \longmapsto \gamma_i^s(t) + (\lambda - \gamma_i^s(t) \cdot u)[1 + (\lambda - \gamma_i^s(t) \cdot u)]u$$

If we replace γ_i^s by $(x, y_i(x, s))$ and write $u = (\sin\theta, \cos\theta)$, the expression for F_i is

$$F_i(x, \theta, \lambda, s) = (x, y_i(x, s)) +$$

$$(\lambda - x \sin\theta - y_i(x, s) \cos\theta)[1 + \lambda - x \sin\theta - y_i(x, s) \cos\theta](\sin\theta, \cos\theta)$$

At $\theta = \lambda = s = 0$ the germ $F_i^0(x) = F_i(x, 0, 0, 0) = (x, y_i(x, 0)) - y_i(x, 0)[1 - y_i(x, 0)](0, 1) = (x, y_i^2(x, 0))$. Taking into account the conditions (i), ..., (iv) above,

$$F_1^0(x) = (x, q_1^2(0) + 2q_1(0)a_1(0)x +$$

$$(2q_1(0)b_1(0) + a_1^2(0))x^2 + 2(a_1(0)b_1(0) + q_1(0)c_1(0))x^3 + O_1(x^4)$$

$$F_2^0(x) = (x, q_1^2(0) + 2q_1(0)a_1(0)x +$$

$$(2q_1(0)b_1(0) + a_1^2(0))x^2 + 2(a_1(0)b_1(0) + q_1(0)c_2(0))x^3 + O_2(x^4)$$

The bi-germ $\{F_1^0, F_2^0\}$ is equivalent to $\{(x, 0), (x, 2q_1(0)(c_2(0) - c_1(0))x^3 + O_2(x^4) - O_1(x^4))\}$ by the change of coordinates $(u, v) \mapsto (u, v - y_1(u, 0))$ in the target. For generic A_2^2 on the curve γ , $c_1(0) - c_2(0) \neq 0$ and $\{F_1^0, F_2^0\}$ is equivalent to $\{(x, 0), (x, x^3 + O(x^4))\}$. But the bi-germ $\{(x, 0), (x, x^3)\}$ is 3- \mathcal{A} -determined (§4), hence $\{F_1^0, F_2^0\}$ is equivalent to $\{(x, 0), (x, x^3)\}$.

5.2.4. Proposition : *For generic 1-parameter families of curves γ_s the family $F = \{F_1, F_2\}$ is a versal unfolding of the bi-germ $\{F_1^0, F_2^0\}$.*

Proof : We showed above that the bi-germ $F_0 = \{F_1^0, F_2^0\}$ is equivalent to $\{(x, 0), (x, x^3)\}$. It is therefore 3- \mathcal{A} -determined. The family $F = \{F_1, F_2\}$ is a versal unfolding of F_0 if and only if

$${}_2J^3T\mathcal{A}_e.F_0 + R \cdot \left\{ {}_2j^3 \frac{\partial F}{\partial \theta}(x, 0, 0, 0), {}_2j^3 \frac{\partial F}{\partial \lambda}(x, 0, 0, 0), {}_2j^3 \frac{\partial F}{\partial s}(x, 0, 0, 0) \right\} = {}_2J^3(1, 2)$$

where ${}_2J^3(1, 2)$ is the set of 3-jets of bi-germs of functions $R \longrightarrow R^2$, and $T\mathcal{A}_e.F_0$ is the pseudo-tangent space of the \mathcal{A} -orbit of F_0 .

It is not difficult to show, using the components of F_0 and $\frac{\partial F}{\partial x}$, that all bi-germs of monomials of degree ≥ 2 are in ${}_2J^3T\mathcal{A}.F_0$, so we need to prove that ${}_2J^1T\mathcal{A}_e.F_0 +$

$R.\{ {}_2j^1 \frac{\partial F}{\partial \theta}, {}_2j^1 \frac{\partial F}{\partial \lambda}, {}_2j^1 \frac{\partial F}{\partial s} \} = {}_2J^1(1, 2)$. To simplify the notation we write $q_1(0) = -q_2(0) = q$, $a_1(0) = -a_2(0) = a$, $a'_1(0) = a'_2(0) = a'$ and $q'_1(0) = q'_2(0) = q'$. We have,

$${}_2j^1 \frac{\partial F}{\partial \theta} = \left\{ \begin{array}{l} (q^2 - q + a(2q - 1)x, (2q - 1)x) \\ (q^2 + q + a(2q + 1)x, -(2q + 1)x) \end{array} \right\}$$

$${}_2j^1 \frac{\partial F}{\partial \lambda} = \left\{ \begin{array}{l} (0, 1 - 2q - 2ax) \\ (0, 1 + 2q + 2ax) \end{array} \right\}$$

$${}_2j^1 \frac{\partial F}{\partial s} = \left\{ \begin{array}{l} (0, 2q'_1q + 2(q'_1a + qa'_1)x) \\ (0, 2q'_2q + 2(q'_2a + qa'_2)x) \end{array} \right\}$$

We denote the components of F_1^0 by f_{11} and f_{12} , and the components of F_2^0 by f_{21} and f_{22} . We consider the following vectors (modulo the constants $\alpha. \left\{ \begin{array}{l} (1, 0) \\ (1, 0) \end{array} \right\}$ and $\beta. \left\{ \begin{array}{l} (0, 1) \\ (0, 1) \end{array} \right\}$ in ${}_2J^1T\mathcal{A}.F_0$): $\left\{ \begin{array}{l} (f_{11}, 0) \\ (f_{21}, 0) \end{array} \right\}$, $\left\{ \begin{array}{l} (0, f_{11}) \\ (0, f_{21}) \end{array} \right\}$, ${}_2j^1 \frac{\partial F}{\partial \theta}$, ${}_2j^1 \frac{\partial F}{\partial \lambda}$, ${}_2j^1 \frac{\partial F}{\partial s}$, ${}_2j^1 \frac{\partial F_1}{\partial x}$. These vectors are written out in matrix form below with respect to the basis indicated on the first row.

$$\begin{array}{cccccc} \left\{ \begin{array}{l} (x, 0) \\ 0 \end{array} \right\} & \left\{ \begin{array}{l} (0, x) \\ 0 \end{array} \right\} & \left\{ \begin{array}{l} 0 \\ (x, 0) \end{array} \right\} & \left\{ \begin{array}{l} 0 \\ (0, x) \end{array} \right\} & \left\{ \begin{array}{l} 0 \\ (1, 0) \end{array} \right\} & \left\{ \begin{array}{l} 0 \\ (0, 1) \end{array} \right\} \\ 1 & 0 & 1 & 0 & 0 & 0 \\ 0 & 1 & 0 & 1 & 0 & 0 \\ 0 & q'_1a + qa'_1 & 0 & q'_2a + qa'_2 & 0 & q(q'_2 - q'_1) \\ (2q - 1)a & 2q - 1 & (2q + 1)a & -(2q + 1) & 2q & 0 \\ 0 & a & 0 & a & 0 & 2q \\ 1 & 2qa & 0 & 0 & 0 & 0 \end{array}$$

The determinant of this matrix is $8q^3(a'_1 - a'_2)$. For $a'_1 - a'_2 \neq 0$, the matrix is invertible and the generators of the basis are in ${}_2J^1T\mathcal{A}.F_0$. Thus ${}_2J^1T\mathcal{A}_e.F_0 + R.\{ {}_2j^1 \frac{\partial F}{\partial \theta}, {}_2j^1 \frac{\partial F}{\partial \lambda}, {}_2j^1 \frac{\partial F}{\partial s} \} = {}_2J^1(1, 2)$. The condition $a'_1 - a'_2 \neq 0$ is satisfied for generic 1-parameter family of curves γ_s when γ_0 has an A_2^2 point. \square

5.2.5. Remark : It is necessary to use the vector ${}_2j^1 \frac{\partial F}{\partial s}$ in order to establish the versal unfolding property of the map F . (The germ $F(x, \theta, \lambda, 0)$ is not a versal

unfolding of F_0 .) Therefore the sections of the big bifurcation set are not the trivial ones.

The bifurcation set of the bi-germ $\{(x, 0), (x, x^3)\}$ is a cusp, and its big bifurcation set is a cuspidal edge (§4). There are two non-trivial generic sections of the cuspidal edge: the lips section and the beaks section [A2] (figure 4.2.5).

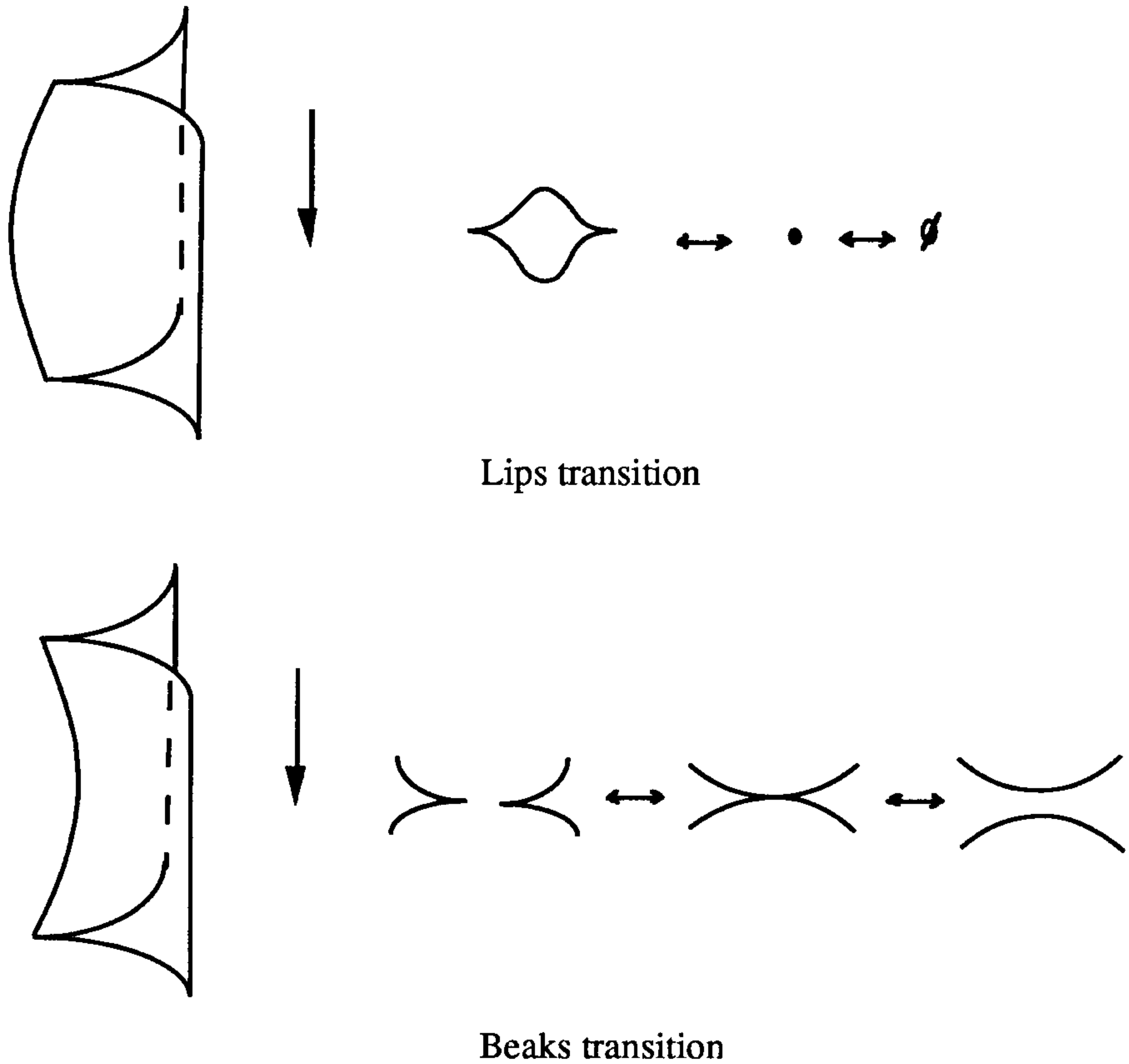

Figure 4.2.5

5.2.6. Corollary : *For generic 1-parameter families of curves γ^s the dual of the symmetry set at an A_2^2 undergoes lips or beaks transitions.* □

The dual of an ordinary inflexion

We keep the same notation as in the A_2^2 case. An inflexion occurs on the SS when the curvatures of the corresponding points on γ_1 and γ_2 have the same absolute value and are of opposite signs. (If γ_1 and γ_2 have the same orientation, the condition is that the curvatures are equal.) This can occur at isolated points on the curve γ , it is a stable feature on symmetry sets. We shall suppose as in the A_2^2 case that the pieces of curves γ_1 and γ_2 are given as graphs of functions, $y_1(x) = q_1 + a_1x + b_1x^2 + c_1x^3 + O_1(x^4)$

for γ_1 and $y_2(x) = q_2 + a_2x + b_2x^2 + c_2x^3 + O_2(x^4)$ for γ_2 , and the bitangent circle is as in (figure 4.2.4). The conditions for having an ordinary inflexion on the symmetry set are expressed by the coefficients $q_i, a_i, b_i, \dots etc$ as follows.

- (i). $q_2 = -q_1$
- (ii). $a_2 = -a_1$
- (iii). $\kappa_2 = -\kappa_1 \iff \frac{2b_2}{(1+a_2^2)^{\frac{3}{2}}} = -\frac{2b_1}{(1+a_1^2)^{\frac{3}{2}}} \iff b_2 = -b_1$ (inflexion)
- (iv). $\kappa'_2 \neq -\kappa'_1 \iff c_2 \neq c_1$ (ordinary inflexion)
- (v). $a_1^2 + 2q_1b_1 + 1 \neq 0$ (the circle is not osculating)

We consider the bi-germ $F = \{F_1, F_2\}$ as in the A_2^2 case with the difference that the coefficients $q_i, a_i, b_i, \dots etc$ are constants and not functions of a variable s . At $\theta = \lambda = 0$ the expressions for $F_i^0 = F_i(x, 0, 0)$ are

$$F_1^0(x) = (x, q_1^2 + 2q_1a_1x + (2q_1b_1 + a_1^2)x^2 + 2(a_1b_1 + q_1c_1)x^3 + O_1(x^4))$$

$$F_2^0(x) = (x, q_1^2 + 2q_1a_1x + (2q_1b_1 + a_1^2)x^2 + 2(a_1b_1 + q_1c_2)x^3 + O_2(x^4))$$

For ordinary inflexions on the symmetry set $c_2 - c_1 \neq 0$, and the bi-germ $\{F_1^0, F_2^0\}$ is equivalent to $\{(x, 0), (x, x^3)\}$ (as in the A_2^2 case).

5.2.7. Proposition : *The family $F = \{F_1, F_2\}$ is a versal unfolding of the bi-germ $\{F_1^0, F_2^0\}$.*

Proof : In the A_2^2 case we considered a 1-parameter family of curves γ_i^s and the big bifurcation set of the big family F . This is because an A_2^2 occurs on isolated points on 1-parameter families of curves, and the family $F(x, \theta, \lambda, 0)$ is not a versal unfolding of the germ $\{F_1^0, F_2^0\}$ (Remark 4.2.4).

The proof of this proposition differs from that of 4.2.3 only on the final step where we have to prove that

$${}_2J^1T\mathcal{A}_e.F_0 + R.\left\{{}_2j^1\frac{\partial F}{\partial\theta}(x, 0, 0), {}_2j^1\frac{\partial F}{\partial\lambda}(x, 0, 0)\right\} = {}_2J^1(1, 2)$$

We consider the following vectors modulo constants in ${}_2J^1T\mathcal{A}.F_0 : \left\{\begin{pmatrix} (f_{11}, 0) \\ (f_{21}, 0) \end{pmatrix}\right\}, \left\{\begin{pmatrix} (0, f_{11}) \\ (0, f_{21}) \end{pmatrix}\right\}, {}_2j^1\frac{\partial F}{\partial\theta}, {}_2j^1\frac{\partial F}{\partial\lambda}, {}_2j^1x\frac{\partial F_1}{\partial x}, \frac{\partial F_1}{\partial x}$. Their coordinates with respect to their generators form the following matrix.

$$\begin{array}{cccccc}
\left\{ \begin{array}{c} (x, 0) \\ 0 \end{array} \right\} & \left\{ \begin{array}{c} (0, x) \\ 0 \end{array} \right\} & \left\{ \begin{array}{c} 0 \\ (x, 0) \end{array} \right\} & \left\{ \begin{array}{c} 0 \\ (0, x) \end{array} \right\} & \left\{ \begin{array}{c} 0 \\ (1, 0) \end{array} \right\} & \left\{ \begin{array}{c} 0 \\ (0, 1) \end{array} \right\} \\
1 & 0 & 1 & 0 & 0 & 0 \\
0 & 1 & 0 & 1 & 0 & 0 \\
(2q-1)a & 2q-1 & (2q+1)a & -(2q+1) & 2q & 0 \\
0 & a & 0 & a & 0 & 2q \\
1 & 2qa & 0 & 0 & 0 & 0 \\
0 & 2(2qb+a^2) & 0 & 0 & -1 & -2qa
\end{array}$$

The determinant of this matrix is $16q^2(a^2 + 2bq + 1)$. The bitangent circle is not biosculating, therefore $a^2 + 2bq + 1 \neq 0$ (condition (v) at the beginning of this section). The generators are in ${}_2J^1T\mathcal{A}.F_0$ and ${}_2J^1T\mathcal{A}_e.F_0 + R.\{{}_2j^1\frac{\partial F}{\partial \theta}(x, 0, 0), {}_2j^1\frac{\partial F}{\partial \lambda}(x, 0, 0)\} = {}_2J^1(1, 2)$. \square

The bifurcation set of the bi-germ $\{(x, 0), (x, x^3)\}$ is a cusp, and

5.2.8. Corollary : *The dual of an ordinary inflexion on the symmetry set is an ordinary cusp.* \square

The dual of a higher inflexion

A higher inflexion occurs on the symmetry set (figure 4.2.4) when $\kappa_2 = -\kappa_1$ and $\kappa'_2 = -\kappa'_1$. It can happen on generic 1-parameter families of curves γ^s . In this case the coefficients $q_i, a_i, b_i, \dots etc$ are functions of a variable s , and the conditions for having a higher inflexion on the SS are :

- (i). $q_2(0) = -q_1(0)$
- (ii). $a_2(0) = -a_1(0)$
- (iii). $\kappa_2(0) = -\kappa_1(0) \iff \frac{2b_2(0)}{(1+a_2^2(0))^{\frac{3}{2}}} = -\frac{2b_1(0)}{(1+a_1^2(0))^{\frac{3}{2}}} \iff b_2(0) = -b_1(0)$ (inflexion)
- (v). $\kappa'_2 = -\kappa'_1 \iff c_2(0) = c_1(0)$ (higher inflexion)
- (iv). $a_1^2(0) + 2q_1(0)b_1(0) + 1 \neq 0$ (the circle is not biosculating)

We consider the bi-germ $F = \{F_1, F_2\}$. At $\theta = \lambda = s = 0$ the expressions for $F_i^0 = F_i(x, 0, 0, 0)$ are

$$F_1^0(x) = (x, q_1^2(0) + 2q_1(0)a_1(0)x + [2q_1(0)b_1(0) + a_1^2(0)]x^2 + \\ 2[a_1(0)b_1(0) + q_1(0)c_1(0)]x^3 + [2a_1(0)c_1(0) + 2q_1(0)d_1(0) + b_1^2(0)]x^4 + O_1(x^5))$$

$$F_2^0(x) = (x, q_1^2(0) + 2q_1(0)a_1(0)x + [2q_1(0)b_1(0) + a_1^2(0)]x^2 + \\ 2[a_1(0)b_1(0) + q_1(0)c_2(0)]x^3 + [2a_1(0)c_1(0) + 2q_1(0)d_2(0) + b_1^2(0)]x^4 + O_2(x^5))$$

For generic higher inflexions on the symmetry set $d_2(0) - d_1(0) = 0$. The bi-germ $\{F_1^0, F_2^0\}$ is then equivalent to $\{(x, 0), (x, x^4)\}$ by the change of coordinates $(u, v) \mapsto (u, v - y_1(u, 0))$ and the fact that $\{(x, 0), (x, x^4)\}$ is 4- \mathcal{A} -determined (§4).

5.2.9. Proposition : *For generic 1-parameter families of curves γ_s , the family $F = \{F_1, F_2\}$ is a versal unfolding of the bi-germ $\{F_1^0, F_2^0\}$.*

Proof: The proof of this proposition is similar to that of Propositions 4.2.3 and 4.2.5. The germ F_0 is 4- \mathcal{A} -determined, so we need to show that

$${}_2J^4T\mathcal{A}_e.F_0 + R.\{{}_2j^4\frac{\partial F}{\partial \theta}(x, 0, 0, 0), {}_2j^4\frac{\partial F}{\partial \lambda}(x, 0, 0, 0), {}_2j^4\frac{\partial F}{\partial s}(x, 0, 0, 0)\} = {}_2J^4(1, 2)$$

One can easily prove that all bi-monomial of degree ≥ 3 are in ${}_2J^4T\mathcal{A}_e.F_0$. For bi-monomials of degree less than 2, we consider the vectors $\left\{ \begin{pmatrix} f_{11}, 0 \\ f_{12}, 0 \end{pmatrix}, \begin{pmatrix} 0, f_{11} \\ 0, f_{12} \end{pmatrix}, \begin{pmatrix} f_{11}^2, 0 \\ f_{12}^2, 0 \end{pmatrix}, \begin{pmatrix} 0, f_{11}^2 \\ 0, f_{12}^2 \end{pmatrix}, {}_2j^2\frac{\partial F}{\partial \theta}(x, 0, 0, 0), {}_2j^2\frac{\partial F}{\partial \lambda}(x, 0, 0, 0), {}_2j^2\frac{\partial F}{\partial s}(x, 0, 0, 0), \frac{\partial F_0}{\partial x}, x\frac{\partial F_0}{\partial x}, x^2\frac{\partial F_0}{\partial x} \right\}$. The determinant of the matrix of their coordinates with respect to their generators is

$$8q^3[(a^2 + 2qb + 1)(b_2'(0) - b_1'(0)) - 3(ab + cq)(a_2'(0) - a_1'(0))]$$

where $q = q_1(0), a = a_1(0), b = b_1(0)$ and $c = c_1(0)$. For generic 1-parameter families of curves γ_s , this determinant is non-zero and the family F is a versal unfolding of F_0 . \square

The bifurcation set of the bi-germ $\{(x, 0), (x, x^4)\}$ is a swallowtail. There is only one generic section of a swallowtail, hence

5.2.10. Corollary : *For generic 1-parameter family of curves γ^s the dual of a higher inflexion on the symmetry set undergoes swallowtail transitions.* \square

The dual of an A_3

There are isolated points on the curve γ where there exists a circle having 4-point contact with the curve. It occurs at points of maximal or minimal curvatures (*i.e.*, $\kappa' = 0$). We know from [B-G-G] that in this case the symmetry set has an ending point.

We suppose that the vertex on the curve is at the origin and the centre of curvature is on the y -axis (figure 4.2.6).

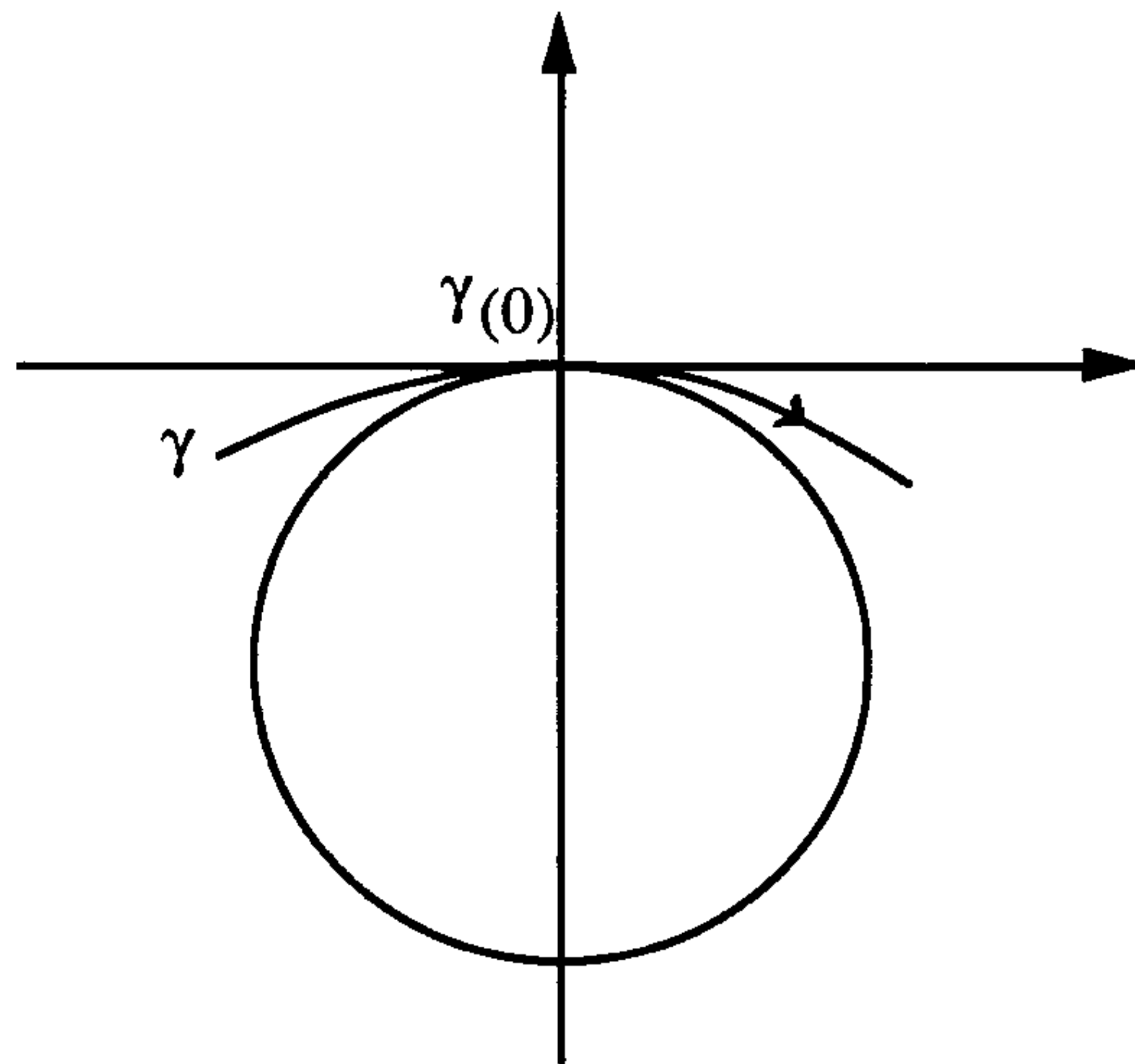

Figure 4.2.6

The curve γ is given as the graph of a $y(x) = q + ax + bx^2 + cx^3 + dx^4 + ex^5 + O(x^6)$ with the following conditions at the origin

- (i). $q = a = 0$
- (ii). $\kappa' = 0 \iff c = 0$ (the origin is a vertex)
- (iii). $\kappa'' \neq 0 \iff d - b^3 \neq 0$ (the origin is an ordinary vertex)

The circle of curvature has radius $r = \frac{1}{\kappa} = \frac{1}{2b}$ and its centre is $(0, \frac{1}{2b})$.

The difference between this case and the previous ones (A_2^2 , inflexion, higher inflexion) is that the points of contact of bitangent circles with the curve are in a neighbourhood of a single point. We consider instead of a bi-germ $\{F_1, F_2\}$ a single germ F . The normal line at the origin to the curve γ is the y -axis. The vector u_0 at that point is $(1,0)$. It is natural to write $u = (\cos\theta, \sin\theta)$ for nearby unit vectors, and identify again L to R^2 . The expression for F becomes

$$F(x, \theta, \lambda) = (x, y(x)) + (\lambda - x\cos\theta - y(x)\sin\theta)[1 - x\cos\theta - y(x)\sin\theta](\cos\theta, \sin\theta)$$

so that at $\theta = \lambda = 0$,

$$F_0(x) = F(x, 0, 0) = (x^2, bx^2 + dx^4 + ex^5 + O(x^6))$$

The change of coordinates $(u, v) \mapsto (u, v - bu - du^2)$ in the target yields $F_0(x)$ equivalent to $(x^2, ex^5 + O(x^6))$. For generic vertices on the curve $e \neq 0$, and since (x^2, x^5) is 5- \mathcal{A} determined, F_0 is \mathcal{A} -equivalent to the germ (x^2, x^5) .

5.2.11. Proposition : *The family F is a versal unfolding of the germ F_0 .*

Proof: Since F_0 is 5- \mathcal{A} determined, the family F is a versal unfolding if and only if

$$J^5T\mathcal{A}_e.F_0 + R.\{j^5\frac{\partial F}{\partial\theta}(x, 0, 0), j^5\frac{\partial F}{\partial\lambda}(x, 0, 0)\} = J^5(1, 2)$$

We have $j^5F_0(x) = (x^2, bx^2 + dx^4 + ex^5)$. Using the components of F_0 we show that $(x^2, 0)$, $(x^4, 0)$, $(0, x^2)$, $(0, x^4)$, and $(0, x^5)$ are in $J^5T\mathcal{A}_e.F_0$. Now, $\frac{\partial F_0}{\partial x} \equiv (2x, 2bx + 4dx^3)$ and considering $x^4\frac{\partial F_0}{\partial x}$ yields $(x^5, 0) \in J^5T\mathcal{A}_e.F_0$.

The vector $\frac{\partial F}{\partial\lambda}(x, 0, 0) \equiv (x, 0)$. For the remaining monomials in $J^5(1, 2)$, we use the following vectors (modulo the monomials obtained above) : $\frac{\partial F}{\partial\theta}(x, 0, 0)$, $x^2\frac{\partial F_0}{\partial x}$, $\frac{\partial F_0}{\partial x}$, and obtain a matrix A of their coordinates with respect to the generators $(x^3, 0)$, $(0, x)$, $(0, x^3)$.

$$A = \begin{pmatrix} 2b & -1 & 0 \\ 1 & 0 & b \\ 0 & b & 2d \end{pmatrix}$$

The determinant of this matrix is $2(d - b^3)$. We pointed out, in the statement of the conditions for an ordinary vertex on γ , that $d - b^3 \neq 0$. The matrix A is invertible and the generators are in $J^5T\mathcal{A}_e.F_0 + R.\{j^5\frac{\partial F}{\partial\theta}(x, 0, 0), j^5\frac{\partial F}{\partial\lambda}(x, 0, 0)\}$. \square

The bifurcation set of the family F is diffeomorphic to that of the versal unfolding of the germ (x^2, x^5) . The latter consists of the union of a smooth curve which represents the dual of the evolute, and a curve with an endpoint which represents the dual of the symmetry set (See §4). The two curves are tangential where they meet (figure 4.2.7).

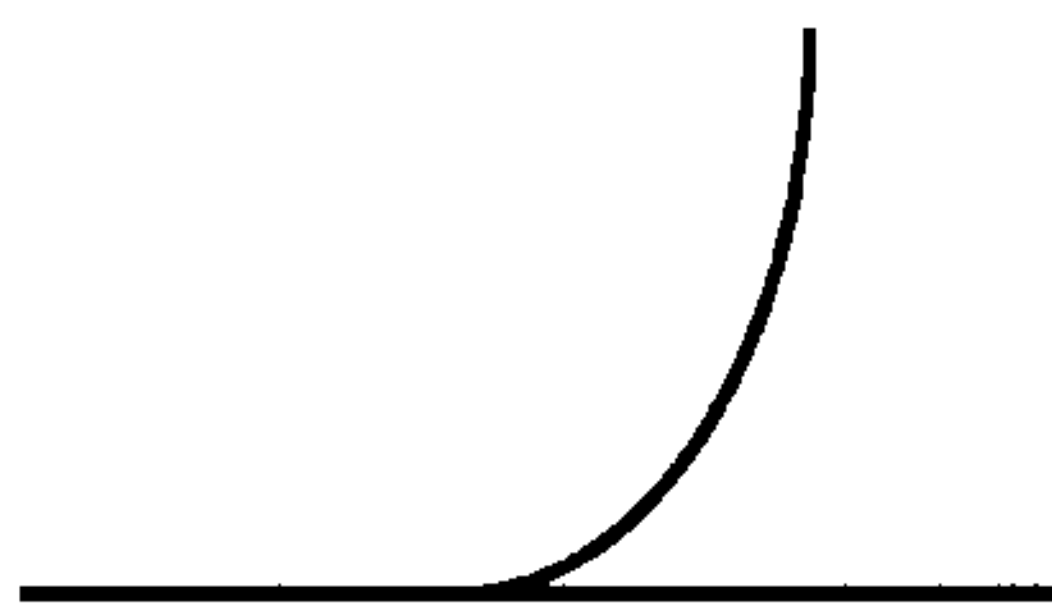

Figure 4.2.7

5.2.12. Corollary : *The dual of an A_3 on the symmetry set is a curve with an endpoint.* \square

The dual of an A_4

An A_4 singularity of the distance squared function on the curve γ occurs at higher vertices, that is when $\kappa' = \kappa'' = 0$. This happens at isolated points on generic 1-parameter families of curves.

The notation here are as in the case of an ordinary vertex. In this case the coefficients q, a, b, c, \dots, etc in the expression of γ as a graph of a function are functions of a variable s . The conditions to have a higher vertex at the origin are

- (i). $q(0) = a(0) = 0$
- (ii). $\kappa'(0) = 0 \iff c = 0$ (the origin is a vertex)
- (iii). $\kappa''(0) = 0 \iff d(0) - b(0)^3 = 0$ (the origin is a higher vertex)

The expression for the big family F is

$$F(x, \theta, \lambda, s) = (x, y(x, s)) + (\lambda - x \cos \theta - y(x) \sin \theta)[1 - x \cos \theta - y(x, s) \sin \theta](\cos \theta, \sin \theta)$$

At $\theta = \lambda = s = 0$,

$$F_0(x) = F(x, 0, 0, 0) = (x^2, b(0)x^2 + d(0)x^4 + e(0)x^5 + O(x^6))$$

For generic higher vertices on the curve $e(0) \neq 0$, and F_0 is \mathcal{A} -equivalent to the germ (x^2, x^5) .

5.2.13. Proposition : *For generic 1-parameter families of curves γ_s , the family F is a versal unfolding of the germ F_0 .*

Proof : The proof follows the same lines that of Proposition 4.2.10. The point of difference is that we can no longer use the matrix A since its determinant vanishes at a higher vertex. But we have the extra vector to use : $\frac{\partial F}{\partial s}(x, 0, 0) \equiv (0, a'(0)x + b'(0)x^2 + c'(0)x^3)$. The matrix of the coordinates of the vectors $\frac{\partial F}{\partial s}(x, 0, 0)$, $\frac{\partial F}{\partial \theta}(x, 0, 0)$, $x^2 \frac{\partial F_0}{\partial x}(x, 0, 0)$ (modulo the obtained monomials) with respect to the generators $(x^3, 0)$, $(0, x)$, $(0, x^3)$ is

$$\begin{pmatrix} 0 & a'(0) & c'(0) \\ 2b(0) & -1 & 0 \\ 1 & 0 & b(0) \end{pmatrix}$$

The determinant of this matrix is $2b^2(0)a'(0) - c'(0)$. For generic 1-parameter families of curves γ_s , $2b^2(0)a'(0) - c'(0) \neq 0$ and the generators $(x^3, 0)$, $(0, x)$, $(0, x^3)$ are in $J^5T\mathcal{A}_e.F_0 + R.\{j^5\frac{\partial F}{\partial\theta}(x, 0, 0), j^5\frac{\partial F}{\partial\lambda}(x, 0, 0), j^5\frac{\partial F}{\partial s}(x, 0, 0)\}$. \square

The bifurcation set of the family F is diffeomorphic to the big bifurcation set of (x^2, x^5) , that is the product of the bifurcation set (x^2, x^5) by a line (§4) (figure 4.2.8).

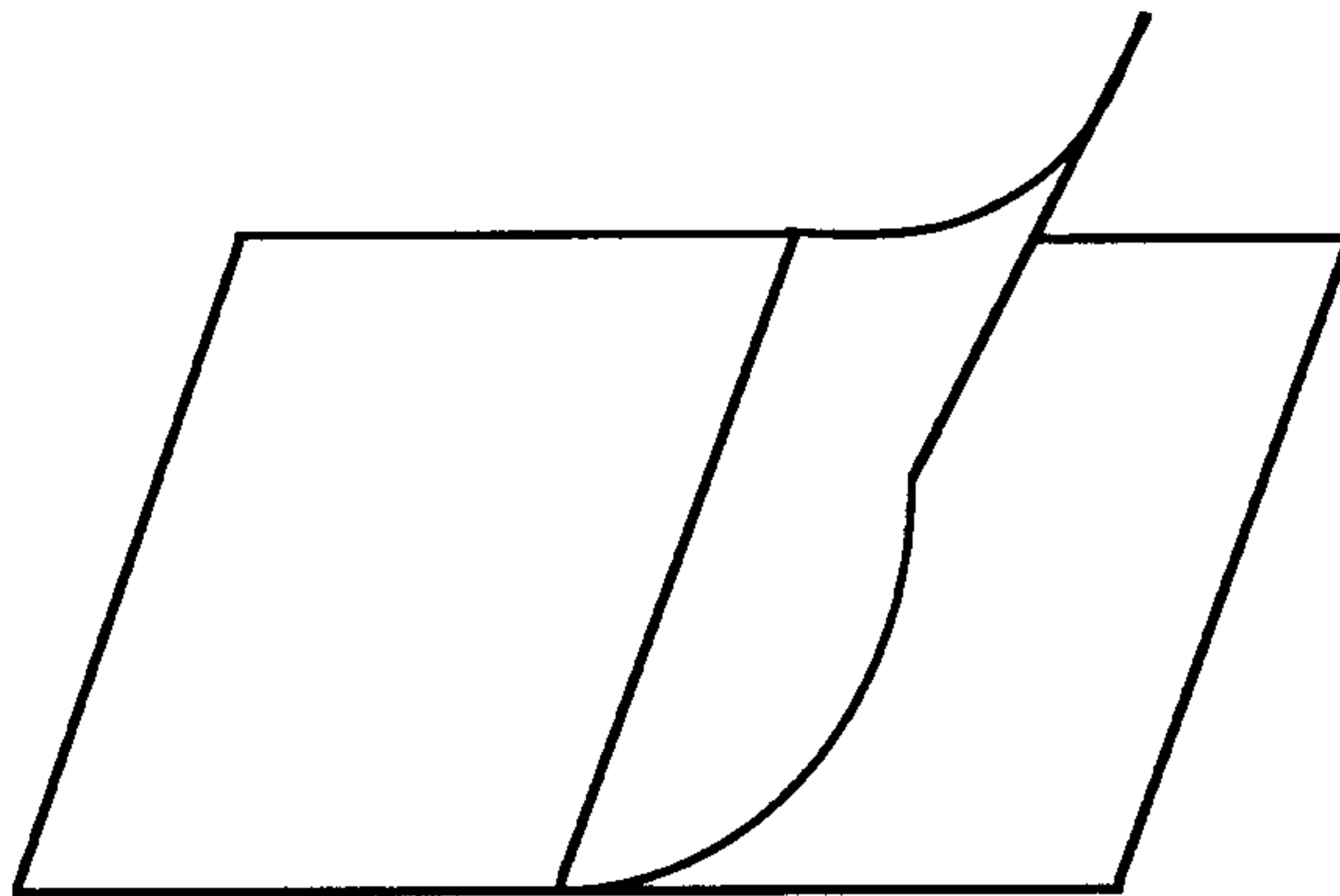

Figure 4.2.8

The family $F(x, \theta, \lambda, 0)$ is not a versal unfolding of the germ F_0 , so the bifurcation set of F is not a product of that of $F(x, \theta, \lambda, 0)$ with a line. The generic transitions on the duals of SS and the evolutes are then recovered by taking non-trivial sections of the big bifurcation set of (x^2, x^5) . We need to find these sections. This is done in §4 using J.W.Bruce's method described in [B1].

In [B-G3], in the generic transitions on the symmetry set at an A_4 point we can see that the dual of the symmetry set should be a compact curve (finite length). So the second transition in (figure 4.4.4 (ii)) does not occur on the duals of SS. (In Proposition 4.3.6, we prove that this transition does not occur.)

5.2.14. Corollary : *The generic transitions on the duals of symmetry set in the A_4 case are those shown in (figure 4.4.4 (i)).* \square

We close this section by drawing all generic transitions in 1-parameter families of duals of SS (figure 4.2.9).

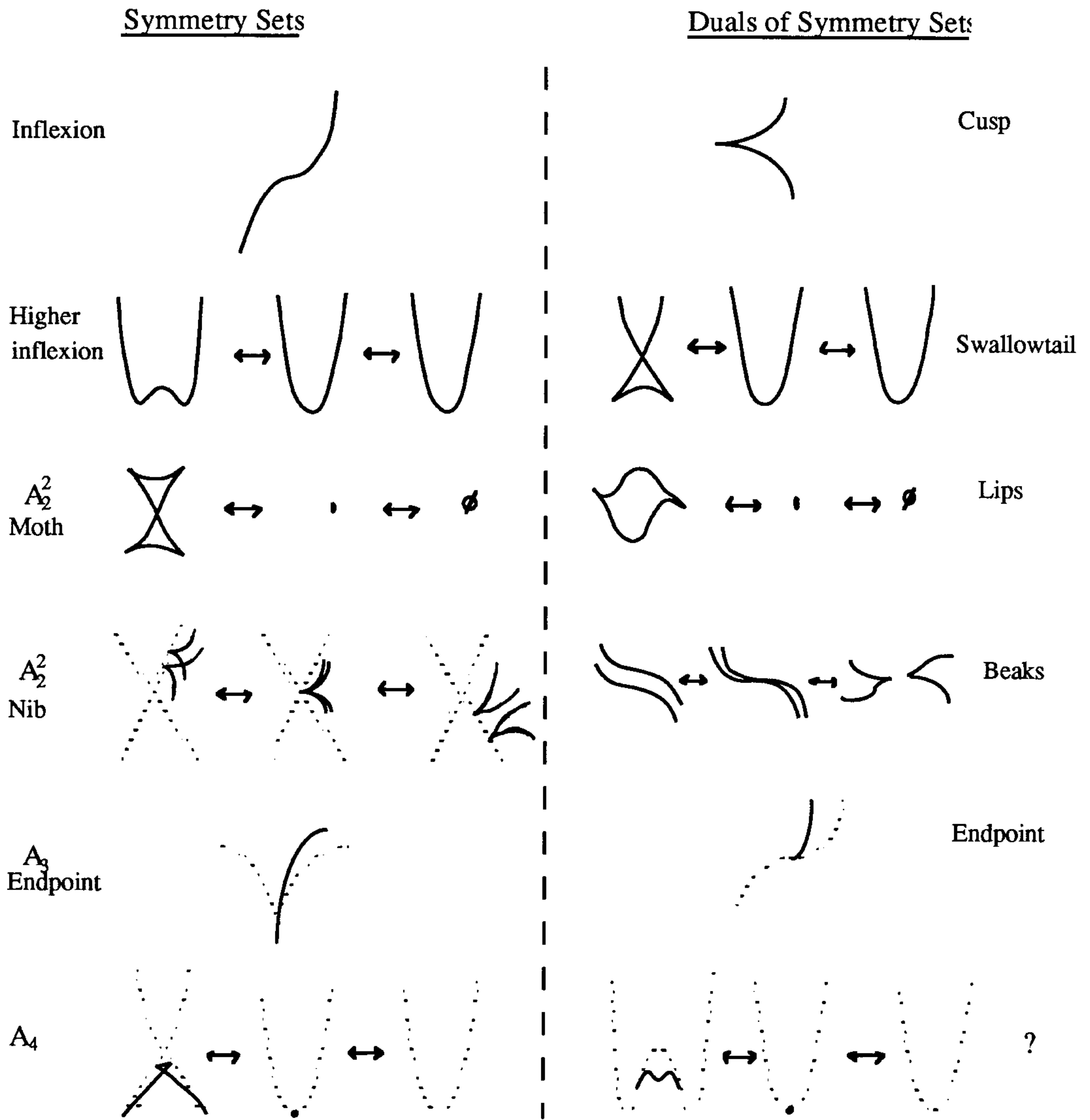

Figure 4.2.9. Transitions on 1-parameter families of duals of symmetry sets

5.2.15. Remarks :

1. The information needed to draw these pictures comes by putting together the previously found transitions on symmetry sets [B-G3] and the new information on duals. Thus cusps correspond to inflexions and vice-versa.

2. The lips in the lips-transition on the dual of the symmetry set have four inflexions and a common tangent line at two different points. This contrasts with the generic lips in projections of surfaces [B2] which has two inflexions only.

§3. The dual of the symmetry set as a discriminant

Let γ be a smooth embedded curve and G the following map

$$G : \mathbf{R} \times \mathbf{R} \longrightarrow L$$

$$(t_1, t_2) \longmapsto \ell(t_1, t_2),$$

where $\ell(t_1, t_2)$ is the perpendicular bisector of the segment $[\gamma(t_1), \gamma(t_2)]$ (figure 4.3.1 (i)). Of course, if $t_1 = t_2$ then ℓ is the normal at $\gamma(t_1)$. For calculations we write a line ℓ in a chosen coordinate system as the set of points (x, y) with $y = ax + b$ and identify ℓ with (a, b) so that $L = \mathbf{R}^2$. (We shall avoid lines parallel to the y -axis in our calculations.)

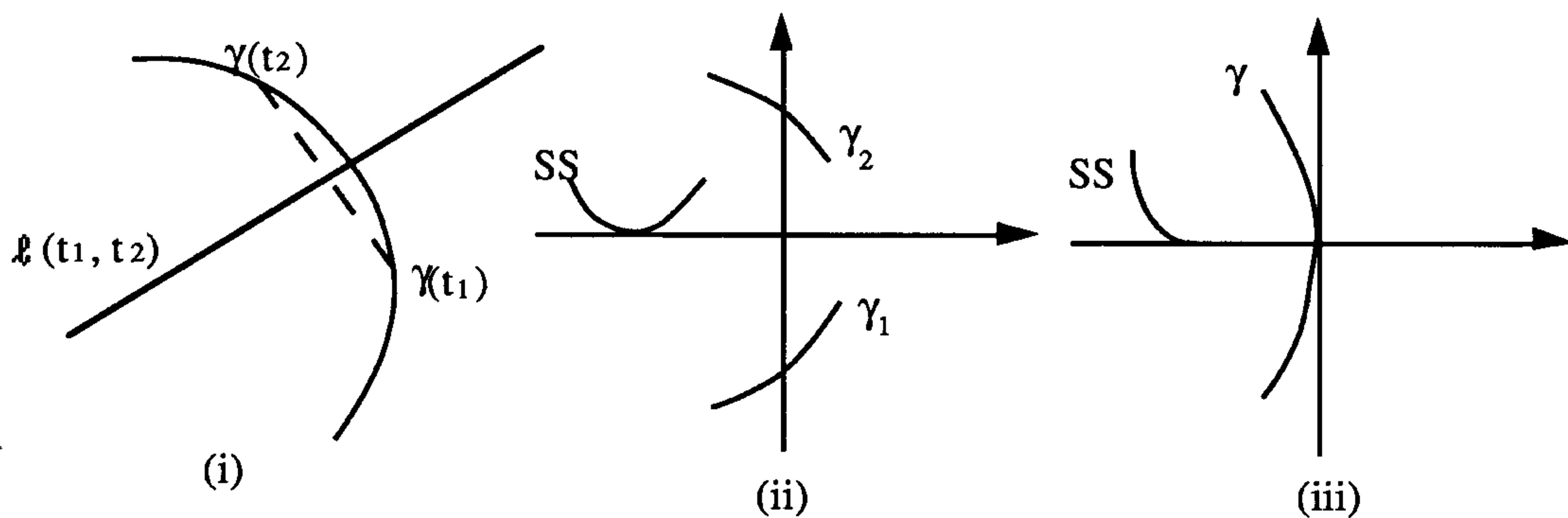

Figure 4.3.1

As in the first method we distinguish two cases :

Case 1.

The symmetry set is locally obtained from two pieces of curve γ_1 and γ_2 . We can write $\gamma_1(x) = (f_1(x), x)$ and $\gamma_2(x) = (f_2(x), x)$ (figure 4.3.1 (ii)).

The line $\ell(x_1, x_2) = (-a(x_1, x_2), b(x_1, x_2))$ can be expressed in terms of f_1, f_2, x_1 and x_2 :

$$a(x_1, x_2) = \frac{f_1(x_1) - f_2(x_2)}{x_1 - x_2},$$

$$b(x_1, x_2) = \frac{1}{2}(x_1 + x_2) + \frac{1}{2}a(x_1, x_2)(f_1(x_1) + f_2(x_2)).$$

The map germ

$$G : \mathbf{R}^2 \longrightarrow \mathbf{R}^2$$

$$(x_1, x_2) \longmapsto (-(a(x_1, x_2), b(x_1, x_2)))$$

is smooth.

5.3.1. Proposition : *The discriminant of the map G is locally the dual of the symmetry set of the curve γ .*

Proof: We need to find the discriminant of the map G and interpret it geometrically as a subset of L . We have

$$DG(x_1, x_2) = \begin{pmatrix} -\frac{\partial a}{\partial x_1} & \frac{1}{2} + \frac{\partial a}{\partial x_1}(f_1(x_1) + f_2(x_2)) + \frac{1}{2}a(x_1, x_2)f_1'(x_1) \\ -\frac{\partial a}{\partial x_2} & \frac{1}{2} + \frac{\partial a}{\partial x_2}(f_1(x_1) + f_2(x_2)) + \frac{1}{2}a(x_1, x_2)f_2'(x_2) \end{pmatrix}$$

where $\frac{\partial a}{\partial x_i}$, $i = 1, 2$ is evaluated at (x_1, x_2) . The map G is singular at (x_1, x_2) when the matrix $DG(x_1, x_2)$ has rank < 2 . The determinant of the matrix $DG(x_1, x_2)$ is

$$|DG(x_1, x_2)| = \frac{1}{2} \left[\frac{\partial a}{\partial x_1} - \frac{\partial a}{\partial x_2} + \left(\frac{\partial a}{\partial x_1} f_2'(x_2) - \frac{\partial a}{\partial x_2} f_1'(x_1) \right) a(x_1, x_2) \right]$$

Differentiating the function a yields

$$\begin{aligned} \frac{\partial a}{\partial x_1} &= \frac{f_1'(x_1)(x_1 - x_2) - (f_1(x_1) - f_2(x_2))}{(x_1 - x_2)^2} \\ \frac{\partial a}{\partial x_2} &= \frac{-f_2'(x_2)(x_1 - x_2) + (f_1(x_1) - f_2(x_2))}{(x_1 - x_2)^2} \end{aligned}$$

So

$$|DG(x_1, x_2)| = \frac{1}{2(x_1 - x_2)} \times [(f_1'(x_1) + f_2'(x_2))a^2(x_1, x_2) + 2(1 - f_1'(x_1)f_2'(x_2))a(x_1, x_2) - (f_1'(x_1) + f_2'(x_2))]$$

(As we are dealing with local properties of the curve γ , we can suppose that the tangents to the curve at x_1 and x_2 are not parallel and none of these vectors is collinear with $\gamma(x_1) - \gamma(x_2)$. That is $f_1'(x_1) - a(x_1, x_2) \neq 0$ and $f_2'(x_2) - a(x_1, x_2) \neq 0$.) The determinant $|DG(x_1, x_2)|$ vanishes when

$$(f_1'(x_1) + f_2'(x_2))a^2(x_1, x_2) + 2(1 - f_1'(x_1)f_2'(x_2))a(x_1, x_2) - (f_1'(x_1) + f_2'(x_2)) = 0 \quad (*)$$

equivalently

$$-\frac{a(x_1, x_2)f_1'(x_1) + 1}{f_1'(x_1) - a(x_1, x_2)} = \frac{a(x_1, x_2)f_2'(x_2) + 1}{f_2'(x_2) - a(x_1, x_2)}$$

and

$$-\frac{-a(x_1, x_2) - \frac{1}{f_1'(x_1)}}{1 - \frac{a(x_1, x_2)}{f_1'(x_1)}} = \frac{-a(x_1, x_2) - \frac{1}{f_2'(x_2)}}{1 - \frac{a(x_1, x_2)}{f_2'(x_2)}} \quad (**)$$

The scalars $-a(x_1, x_2)$, $\frac{1}{f_1'(x_1)}$, $\frac{1}{f_2'(x_2)}$ are the slopes of the line ℓ , the tangent line to the curve γ_1 at $\gamma_1(x_1)$ and the tangent line to the curve γ_2 at $\gamma_2(x_2)$ respectively. Let $\tan\theta = -a(x_1, x_2)$, $\tan\theta_1 = \frac{1}{f_1'(x_1)}$ and $\tan\theta_2 = \frac{1}{f_2'(x_2)}$ (figure 4.3.2).

Then equation (**) becomes $\tan(\theta - \theta_1) = -\tan(\theta - \theta_2)$. That is to say that the line ℓ is the perpendicular bisector of the segment $[\gamma_2(x_2), \gamma_1(x_1)]$. This is exactly the necessary and sufficient condition for the existence of a bitangent circle at $\gamma_1(x_1)$ and $\gamma_2(x_2)$. The tangent line to the SS at the corresponding point is the line ℓ . \square

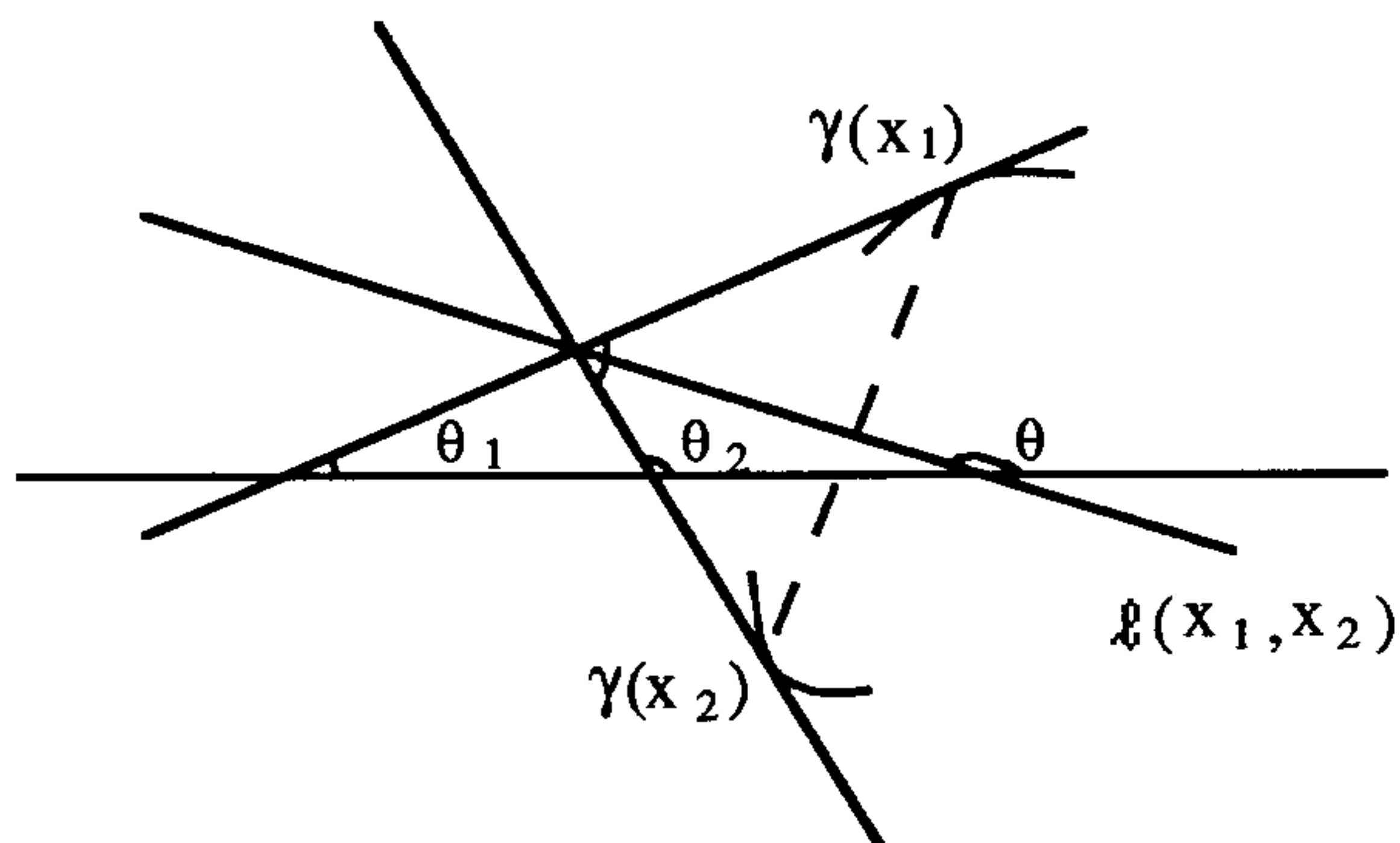

Figure 4.3.2

5.3.2. Remark : The dual of the SS in this case is expressed as the discriminant of a map germ from the plane to the plane. Thus we expect in the codimension ≤ 1 cases the occurrence of stable cusps, swallowtails, lips and beaks transitions [R1]. This is indeed the case, as can be seen in (figure 4.2.9).

Case 2

The symmetry set here is locally obtained from a neighbourhood of a point on a single curve γ . The point is generically a vertex but higher vertices can occur in 1-parameter families of curves. If we write γ locally in the form $\gamma(x) = (f(x), x)$ where f is a smooth function (figure 4.3.1 (iii)) then:

$$a(x_1, x_2) = \frac{f(x_1) - f(x_2)}{x_1 - x_2}$$

$$b(x_1, x_2) = \frac{1}{2}(x_1 + x_2) + \frac{1}{2}a(x_1, x_2)(f(x_1) + f(x_2))$$

are well defined smooth symmetric maps with $a(x, x) = f'(x)$ and $b(x, x) = x + f'(x)f(x)$. The line $(-a(x, x), b(x, x))$ is the normal to the curve γ at $\gamma(x)$. The map germ

$$G : \mathbf{R}^2 \longrightarrow \mathbf{R}^2$$

$$(x_1, x_2) \longmapsto (-a(x_1, x_2), b(x_1, x_2))$$

is a smooth, and

5.3.3. Proposition : *The discriminant of the germ G is locally the union of the dual of the symmetry set and the dual of the evolute of the curve γ .*

Proof: We have

$$DG(x_1, x_2) = \begin{pmatrix} -\frac{\partial a}{\partial x_1} & \frac{1}{2} + \frac{\partial a}{\partial x_1}(f(x_1) + f(x_2)) + \frac{1}{2}a(x_1, x_2)f'(x_1) \\ -\frac{\partial a}{\partial x_2} & \frac{1}{2} + \frac{\partial a}{\partial x_2}(f(x_1) + f(x_2)) + \frac{1}{2}a(x_1, x_2)f'(x_2) \end{pmatrix}$$

A simple calculation of a limit shows that $\frac{\partial a}{\partial x_1}(x, x) = f''(x)$. The origin is not an inflexion on the curve γ , so $f''(0) \neq 0$ and the property holds in a neighbourhood of the origin. The matrix $DG(x, x)$ is of rank 1, the diagonal is part of the singular set of the map G , and its image, which is the dual curve of the evolute, is a subset of the discriminant of G .

The determinant of the matrix $DG(x_1, x_2)$ is

$$|DG(x_1, x_2)| = \frac{1}{2(x_1 - x_2)} \times \\ [(f'(x_1) + f'(x_2))a^2(x_1, x_2) + 2(1 - f'(x_1)f'(x_2))a(x_1, x_2) - (f'(x_1) + f'(x_2))]$$

When $x_1 \neq x_2$ the determinant $|DG(x_1, x_2)|$ vanishes when

$$[(f'(x_1) + f'(x_2))a^2(x_1, x_2) + 2(1 - f'(x_1)f'(x_2))a(x_1, x_2) - (f'(x_1) + f'(x_2))] = 0$$

This equation is similar to (*) in the proof of Proposition 4.3.1, and the subset of the discriminant of G which results from it is the dual of the symmetry set. \square

The map G is a symmetric map with respect to reflexion in the diagonal $\Delta = \{(x, x), x \in R\}$. The symmetric germs $R^2 \rightarrow R^2$ are the invariant germs of the action of Z_2 on the source, where the group Z_2 is generated by reflexion in the diagonal Δ . The equivariant change of coordinates in the source $(x, y) \mapsto (x+y, x-y)$ transforms symmetry with respect to Δ to symmetry with respect to the x-axis.

A classification of invariant germs up to equivariant change of coordinates in the source (Z_2 acting by reflexion in the x-axis), and any change of coordinates in the target, can be deduced from the classification of germs of projections of surfaces with boundary ([B-G4], remarks following Theorem 1.2). All that is needed is to replace in the list of normal forms obtained in ([B-G4], Table 5.1) y by y^2 . We shall give a proof of this statement as it was not proved in [B-G4]. In the following we introduce the notation needed.

Notation

In this chapter we deal with the action of the group Z_2 in the source but there is an equivariant theory which deals with actions of compact Lie groups in the source and target [Ro],[W4]. We denote by $C_2^{\times 2}$ the set of germs $R^2, 0 \rightarrow R^2, 0$. The group \mathcal{B} in [B-G4] (see also Chapter 1) is the subgroup of diffeomorphisms $(h, k) \in \mathcal{A}$ with

h preserving the surface with boundary $\{(x, y) : y \geq 0\}$ in the source. The group Z_2 has two elements, the identity map in R^2 and g the reflexion with respect to the x -axis, that is $g(x, -y) = g(x, y)$. It acts on the source by reflexion and trivially on the target. This induces an action on $C_2^{\times 2}$

$$\begin{aligned} Z_2 \times C_2^{\times 2} &\longrightarrow C_2^{\times 2} \\ (g, f) &\longmapsto f^g \end{aligned}$$

with $f^g(x, y) = g^{-1}.f.g(x, y) = f.g(x, y) = f(x - y)$. The invariant germs of this action are those satisfying $f^g = f$. The set of all invariant germs is denoted by $(C_2^{\times 2})^{Z_2}$, and it is not hard to see that it is exactly the set of symmetric maps with respect to the x -axis. Any symmetric map with respect to the x -axis is written $f \circ \sigma$ with $f \in C_2^{\times 2}$ and σ is the fold map $(x, y) \mapsto (x, y^2)$, so that $(C_2^{\times 2})^{Z_2} = C_2^{\times 2} \circ \sigma$.

Let \mathcal{R}^{Z_2} , \mathcal{L}^{Z_2} , \mathcal{A}^{Z_2} be the sets of equivariant diffeomorphisms, with \mathcal{R} , \mathcal{L} , \mathcal{A} the standard Mather groups. We have $h \in \mathcal{R}^{Z_2}$ if $h^g = g^{-1}.h.g = h$. Let $h = (u, v)$ then

$$h \in \mathcal{R}^{Z_2} \iff (u(x, y), v(x, y)) = (u(x, -y), -v(x, -y))$$

The action of Z_2 on the target is trivial, so $\mathcal{L}^{Z_2} = \mathcal{L}$ and $\mathcal{A}^{Z_2} = \mathcal{R}^{Z_2} \times \mathcal{L}$. The action of \mathcal{A} on $C_2^{\times 2}$ induces an action of \mathcal{A}^{Z_2} on $(C_2^{\times 2})^{Z_2}$.

5.3.4. Theorem : *The orbits of the action of \mathcal{A}^{Z_2} on $(C_2^{\times 2})^{Z_2}$ are the images of the orbits of the action of \mathcal{B} on $C_2^{\times 2}$ by the map σ .*

The orbits of the action of \mathcal{B} are the different types of orthogonal projections of surfaces with boundary [B-G4]

Proof : Let $\mathcal{O}_{\mathcal{B}}(f)$ be the \mathcal{B} orbit of f . We shall prove that

$$\mathcal{O}_{\mathcal{B}}(f) \circ \sigma = \mathcal{O}_{\mathcal{B}^{Z_2}}(f \circ \sigma)$$

We have $\mathcal{O}_{\mathcal{B}}(f) = \{k \circ f \circ h : (h, k) \in \mathcal{B}\}$. Let $h(x, y) = (h_1(x, y), h_2(x, y))$. Since h preserves the x -axis $h_2(x, 0) = 0$, and by Hadamard's lemma $h_2(x, y) = y\tilde{h}_2(x, y)$. The map h preserves the surface with boundary $\{(x, y) : y \geq 0\}$, so $\tilde{h}_2(0, 0) > 0$. The function $v(x, y) = \sqrt{\tilde{h}_2(x, y)}$ is then well defined and smooth in a neighbourhood of the origin. Let $F = (k \circ f \circ h) \circ \sigma$. Then

$$\begin{aligned} F(x, y) &= k(f(h_1(x, y^2), y^2\tilde{h}_2(x, y^2))) \\ &= k(f(h_1(x, y^2), y^2v^2(x, y^2))) \\ &= k(f(h_1(x, y^2), (yv(x, y^2))^2)) \\ &= k \circ (f \circ \sigma) \circ H(x, y) \end{aligned}$$

with $H(x, y) = (h_1(x, y^2), yv(x, y^2))$. The map H is a diffeomorphism since $|DH(0, 0)| = \frac{\partial h_1}{\partial x}(0, 0) \cdot v(0, 0) \neq 0$, and it is easy to see that H is in \mathcal{R}^{Z_2} . So $\mathcal{O}_{\mathcal{B}}(f) \circ \sigma \subset \mathcal{O}_{\mathcal{B}^{Z_2}}(f \circ \sigma)$.

Conversely, let $F = k \circ (f \circ \sigma) \circ H$ be in $\mathcal{O}_{\mathcal{B}^G}(f \circ \sigma)$. If $H = (H_1, H_2)$ then $H_1(x, -y) = H_1(x, y)$ and $H_2(x, -y) = -H_2(x, y)$. Thus $H_1(x, y) = u(x, y^2)$ and $H_2(x, y) = yv(x, y^2)$ with $\frac{\partial u}{\partial x}(0, 0) \cdot v(0, 0) \neq 0$ is the condition for H to be a local diffeomorphism. We have

$$\begin{aligned} F(x, y) &= k(f(H_1(x, y^2), H_2^2(x, y^2))) \\ &= k(f(u(x, y^2), y^2 v^2(x, y^2))) \\ &= (k \circ f \circ h)\sigma(x, y) \end{aligned}$$

with $h(x, y) = (u(x, y), yv^2(x, y))$. The claim is that (h, k) is in \mathcal{B} . The fact that h is a diffeomorphism comes from $|Dh(0, 0)| = \frac{\partial u}{\partial x}(0, 0) \cdot v^2(0, 0) \neq 0$ because H is a diffeomorphism. It is clear that h preserves the x -axis and maps the surface with boundary $\{(x, y) : y \geq 0\}$ to itself. Thus $\mathcal{O}_{\mathcal{B}^{Z_2}}(f \circ \sigma) \subset \mathcal{O}_{\mathcal{B}}(f) \circ \sigma$. \square

The above theorem yields the following table of normal forms of symmetric map germs of rank greater than 1 and of codimension less than 2, where we also give the codimension and the name of the corresponding boundary singularity.

5.3.5. Table of normal forms ($\epsilon = \pm 1$)

Normal form	Name of the boundary singularity	Codimension
I. (x, y^2)	Submersion	0
II. $(x, xy^2 + y^4)$	Semi-fold	0
III. $(x, xy^2 + y^6)$	Semi-cusp	1
IV. $(x, x^2y^2 + \epsilon y^4)$	Semi-lips ($\epsilon = +1$) Semi-beaks ($\epsilon = -1$)	1
V. $(y^2 + x^3, x^2)$	Boundary cusp	1

5.3.6. Proposition : *The germ G is equivalent in the equivariant sense to the germ $(x, xy^2 + y^4)$ at an A_3 on the curve and to $(x, x^2y^2 + y^4)$ at an A_4 .*

Proof: We can choose a local coordinate system with the origin the vertex on the curve and the y -axis the tangent line at the vertex (figure 4.2.6). We write $\gamma(x) = (f(x), x)$ with $f(0) = f'(0) = 0$. Calculations of the curvature function κ and its successive derivatives show that

$$\kappa(0) = -f''(0)$$

$$\kappa'(0) = -f'''(0)$$

$$\kappa''(0) = -f^{(4)}(0) + 3(f'''(0))^2$$

The origin is an ordinary vertex when $f'''(0) = 0$ and $-f^{(4)}(0) + 3(f'''(0))^2 \neq 0$. It is a higher vertex if $f'''(0) = -f^{(4)}(0) + 3(f'''(0))^2 = 0$. (Note that the origin is not an inflexion on γ , that is $f''(0) \neq 0$.)

We write locally at the origin $f(x) = \alpha x^2 + \beta x^4 + \delta x^5 + O(x^6)$ with $\alpha = \frac{1}{2!}f''(0)$, $\beta = \frac{1}{4!}f^{(4)}(0)$ and $\delta = \frac{1}{5!}f^{(5)}(0)$. The relation between α and β is $\alpha^3 - \beta \neq 0$ if the origin is an ordinary vertex, and $\alpha^3 - \beta = 0$ if it is a higher vertex. For generic vertices on the curve we expect $\delta \neq 0$. With this expression for f we have

$$a(x_1, x_2) = \frac{f(x_1) - f(x_2)}{x_1 - x_2} = \alpha(x_1 + x_2) + \beta(x_1 + x_2)(x_1^2 + x_2^2) + \delta \sum_{i=0}^4 x_1^{4-i} x_2^i + h.o.t$$

where *h.o.t* is an abbreviation for higher order terms. The equivariant change of coordinates $x_1 = x - y$ and $x_2 = x + y$ transforms the symmetry with respect to the diagonal Δ to the symmetry with respect to the x -axis. The expression for a in this new coordinate system is

$$a(x, y) = 2\alpha x + 4\beta x(x^2 + y^2) + \delta(5x^4 + 12x^2y^2 + y^4) + h.o.t$$

Let $X = 2\alpha x + 4\beta x(x^2 + y^2) + \delta(5x^4 + 12x^2y^2 + y^4)$ and $Y = y$. The map $(x, y) \mapsto (X, Y)$ is an equivariant diffeomorphism and $x = \frac{1}{2\alpha}X - \frac{\beta}{\alpha^2}XY^2 - \frac{\delta}{2\alpha}Y^4 - \frac{5\delta}{4\alpha^3}X^2Y^2 + h.o.t$. The map G is written in the new coordinate system (X, Y) in the source as follows:

$$G(X, Y) = (-X, \frac{\alpha^3 - \beta}{\alpha^2}XY^2 - \frac{5\delta}{\alpha^3}X^2Y^2 - \frac{\delta}{2\alpha}Y^4) + h.o.t$$

At an A_3 point (ordinary vertex) $\alpha^3 - \beta \neq 0$ and the map G is equivalent, in the equivariant sense, to $(X, XY^2 + Y^4) + h.o.t$. The germ $(X, XY^2 + Y^4)$ is $4\text{-}\mathcal{A}^{Z_2}$ -determined, therefore G is equivalent to $(X, XY^2 + Y^4)$.

At an A_4 point (higher vertex) $\alpha^3 - \beta = 0$ and it is not difficult to see that G is equivalent $(X, X^2Y^2 + Y^4)$. \square

The germ $(x, xy^2 + y^4)$ is stable and its discriminant is drawn in (figure 4.3.3 (i)). The germ $(x, x^2y^2 + y^4)$ is of codimension 1. Generic sections of the discriminant of its versal unfolding are as in (figure 4.3.3 (ii)).

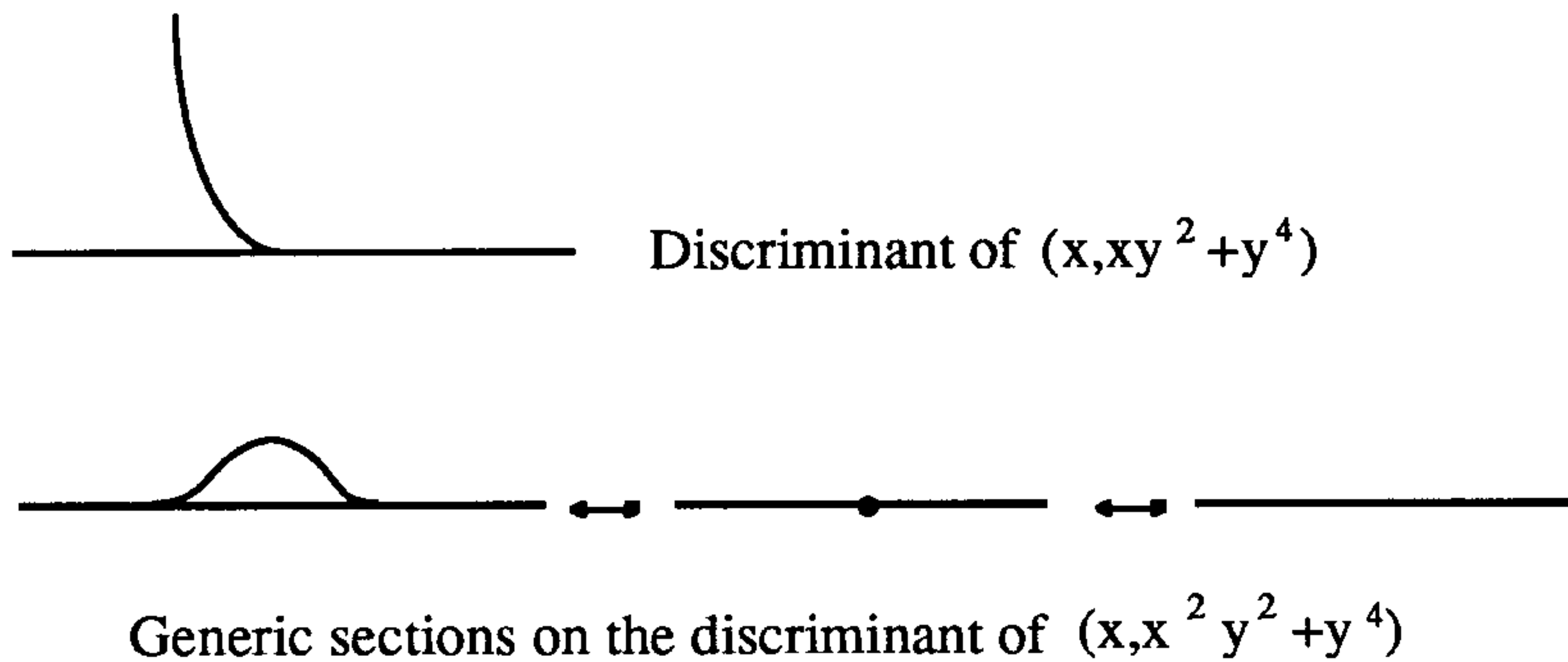

Figure 4.3.3

Taking into account the presence of inflexions on the duals, Proposition 4.3.6 confirms the transitions on the dual of symmetry set and evolute at an A_3 and A_4 shown in (figure 4.2.9). In the A_4 case the method of expressing the duals of symmetry sets and evolutes as discriminants gives a more precise account of what transition occurs on the dual of the symmetry set.

§4. Appendix

In this section we calculate the bifurcation sets of the bi-germs and germs in §2. We give a classification of bi-germs and germs of maps $R, 0 \rightarrow R^2, 0$ up to smooth changes of coordinates in the source and target. The method of classification and the machinery behind it is given in Chapter 1. We shall omit the calculation of determinacy.

I. The bi-germs $R, 0 \rightarrow R^2, 0$

The case of the bi-germs needs some clarification since the group acting is quite special. Let $C_1^{\times 2}$ denote the ring of germs $R, 0 \rightarrow R^2, 0$. A bi-germ is an element of the ring $C_1^{\times 2} \times C_1^{\times 2}$. If F is a bi-germ we write $F = (f_1, f_2)$.

Two bi-germs $F = (f_1, f_2)$ and $G = (g_1, g_2)$ are \mathcal{A} -equivalent if there exist diffeomorphisms h_1, h_2 preserving the origin in the source, and a diffeomorphism k preserving the origin in the target, such that the following diagram commutes.

$$\begin{array}{ccccc} R, 0 & \xrightarrow{f_1} & R^2, 0 & \xleftarrow{f_1} & R, 0 \\ \uparrow h_1 & & \downarrow k & & \uparrow h_2 \\ R, 0 & \xrightarrow{g_1} & R^2, 0 & \xleftarrow{g_1} & R, 0 \end{array}$$

Such an equivalence relation induces an action of the group $\mathcal{A} = \mathcal{R} \times \mathcal{R} \times \mathcal{L}$ on $C_1^{\times 2} \times C_1^{\times 2}$ defined by $(h_1, h_2, k) \cdot (f_1, f_2) = (k \circ f_1 \circ h_1^{-1}, k \circ f_2 \circ h_2^{-1})$. The tangent space to the orbit of the bi-germ $F = (f_1, f_2)$ is

$$T\mathcal{A}.F = \{(df_1 \circ \psi_1, df_2 \circ \psi_2) : \psi_1, \psi_2 \in m.C_1^{\times 2}\} + \{(\phi \circ f_1, \phi \circ f_2) : \phi \in m.C_2^{\times 2}\}$$

and the pseudo tangent space is

$$T\mathcal{A}_e.F = \{(df_1 \circ \psi_1, df_2 \circ \psi_2): \psi_1, \psi_2 \in C_1^{\times 2}\} + \{(\phi \circ f_1, \phi \circ f_2): \phi \in C_2^{\times 2}\}$$

The codimension of F is the dimension of the real vector space $C_1^{\times 2} \times C_1^{\times 2} / T\mathcal{A}_e.F$.

There are analogous theorems on determinacy, method of classification and versality to those stated in Chapter 1. We shall classify bi-germs inductively on the jet level until a sufficient jet is reached. We denote by ${}_2J^k(1, 2)$ the set of bi-germs of polynomials of degree $\leq k$ and by \simeq_k the \mathcal{A} -equivalence relation induced on ${}_2J^k(1, 2)$.

The 1-jet $F = \left\{ \begin{array}{l} (ax, bx) \\ (cx, dx) \end{array} \right\}$.

Using explicit linear changes of coordinates in the source and target yields

$$\begin{aligned} F &\simeq_1 \left\{ \begin{array}{l} (x, 0) \\ (0, x) \end{array} \right\} && \text{If } ab - cd \neq 0 \\ &\simeq_1 \left\{ \begin{array}{l} (x, 0) \\ (x, 0) \end{array} \right\} && \text{If } ab - cd = 0, a, c \neq 0 \text{ or } b, d \neq 0 \\ &\simeq_1 \left\{ \begin{array}{l} (x, 0) \\ (0, 0) \end{array} \right\} && \text{If only one of } a, b, c, d \text{ is not zero} \\ &\simeq_1 \left\{ \begin{array}{l} (0, 0) \\ (0, 0) \end{array} \right\} && \text{If } a = b = c = d = 0 \end{aligned}$$

5.4.1. Proposition : (1). The bi-germ $\left\{ \begin{array}{l} (x, 0) \\ (0, x) \end{array} \right\}$ is stable

(2) The orbits in ${}_2J^k(1, 2)$ with $(k-1)$ -jet $\left\{ \begin{array}{l} (x, 0) \\ (x, 0) \end{array} \right\}$ are $\left\{ \begin{array}{l} (x, x^k) \\ (x, 0) \end{array} \right\}$ and $\left\{ \begin{array}{l} (x, 0) \\ (x, 0) \end{array} \right\}$. The bi-germ $\left\{ \begin{array}{l} (x, x^k) \\ (x, 0) \end{array} \right\}$ is $k - \mathcal{A}$ -determined with codimension $k - 1$.
□

5.4.2. Remarks : (1). A versal unfolding of $\left\{ \begin{array}{l} (x, x^k) \\ (x, 0) \end{array} \right\}$ is $\tilde{F}(x, u_1, \dots, u_{k-1}) = \left\{ \begin{array}{l} (x, x^k + u_1 x^{k-2} + u_2 x^{k-3} + \dots + u_{k-1}) \\ (x, 0) \end{array} \right\}$

(2). The bi-germs $\left\{ \begin{array}{l} (x, 0) \\ (0, 0) \end{array} \right\}$ and $\left\{ \begin{array}{l} (0, 0) \\ (0, 0) \end{array} \right\}$ are not of interest in this chapter. They do not give rise to bi-germs which occur in the study of 1-parameter families of duals of symmetry sets.

5.4.3. The bifurcation sets of the unfoldings of $\left\{ \begin{array}{l} (x, 0) \\ (0, 0) \end{array} \right\}$, $k = 2, 3, 4$

The bifurcation set of a family of bi-germs $F(x, u) = (f_1(x, u), f_2(x, u))$ is $B(F) = \{u: \exists x_1, x_2 \text{ such that } f_1(x_1, u) = f_2(x_2, u) \text{ and } \frac{\partial f_1}{\partial x}(x_1, u) // \frac{\partial f_2}{\partial x}(x_2, u)\}$ (see Definition 4.2.1).

Case $k = 2$

In this case $f_1(x, u_1) = (x, x^2 + u_1)$ and $f_2(x, u_1) = (x, 0)$. We have

$$f_1(x_1, u_1) = f_2(x_2, u_1) \iff (x_1, x_1^2 + u_1) = (x_2, 0) \iff \begin{cases} x_1 = x_2 \\ u_1 = -x_1^2 \end{cases}$$

and

$$\frac{\partial f_1}{\partial x}(x_1, u_1) // \frac{\partial f_2}{\partial x}(x_2, u_1) \iff (1, 2x_1) // (1, 0) \iff x_1 = 0$$

Therefore $B(F)$ is the single point 0, $B(F) = \{0\}$.

Case $k = 3$

Here $f_1(x, u_1, u_2) = (x, x^3 + u_1x + u_2)$ and $f_2(x, u_1) = (x, 0)$. We have

$$\begin{aligned} f_1(x_1, u_1, u_2) = f_2(x_2, u_1, u_2) &\iff (x_1, x_1^3 + u_1x_1 + u_2) = (x_2, 0) \\ &\iff \begin{cases} x_1 = x_2 \\ x_1^3 + u_1x_1 + u_2 = 0 \end{cases} \end{aligned}$$

and

$$\frac{\partial f_1}{\partial x}(x_1, u_1, u_2) // \frac{\partial f_2}{\partial x}(x_2, u_1, u_2) \iff (1, 3x_1^2 + u_1) // (1, 0) \iff u_1 = -3x_1^2$$

The bifurcation case in this case is then $B(F) = \{(-3x_1^2, 2x_1^3): x_1 \in \mathbb{R}, 0\}$, which is a cusp.

Case $k = 3$

In this case $f_1(x, u_1, u_2, u_3) = (x, x^4 + u_1x^2 + u_2x + u_3)$ and $f_2(x, u_1) = (x, 0)$. Similar calculations to those above show that

$$(u_1, u_2, u_3) \in B(F) \iff \begin{cases} x_1^4 + u_1x_1^2 + u_2x_1 + u_3 = 0 \\ 4x_1^3 + 2u_1x_1 + u_2 = 0 \end{cases}$$

The bifurcation set is then $B(F) = \{(u, -4x^3 - 2ux, 3x^4 + ux): x, u \in \mathbb{R}, 0\}$. This is a swallowtail (figure 4.4.1).

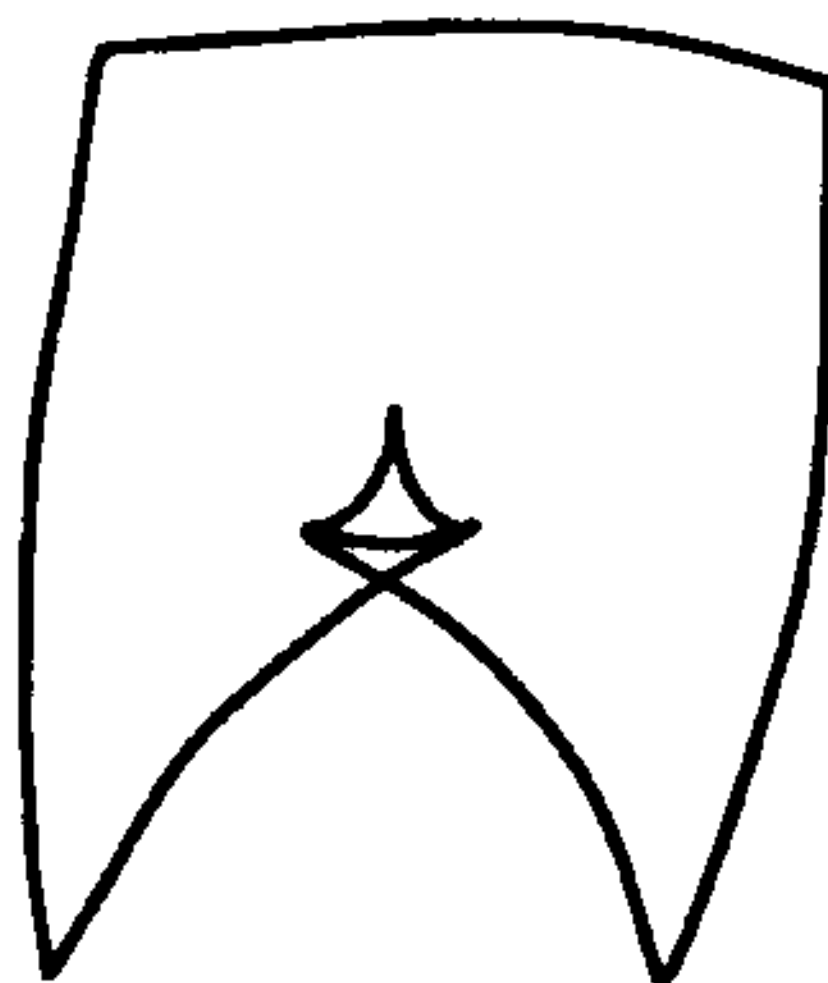

Figure 4.4.1

II. The germs $R, 0 \longrightarrow R^2, 0$

The \mathcal{A} -classification of germs $R, 0 \longrightarrow R^2, 0$ of low codimension is given in [R2]. In this chapter there is only one germ of interest, the germ (x^2, x^5) (see Propositions 4.2.11 and 4.2.13). We shall calculate its bifurcation set.

A versal unfolding of (x^2, x^5) is $F(x, u, v) = (x^2, x^5 + ux^3 + vx)$ [R2]. The bifurcation set of F has two components,

$$B(F) = \{(u, v): \exists x \text{ such that } F(x, u, v) = \frac{\partial F}{\partial x}(x, u, v) = (0, 0)\} \cup \\ \{(u, v): \exists x_1, x_2 \text{ such that } F(x_1, u, v) = F(x_2, u, v) \text{ and } \frac{\partial F}{\partial x}(x_1, u, v) // \frac{\partial F}{\partial x}(x_2, u, v)\}$$

It is not hard to see that

$$\{(u, v): \exists x \text{ such that } F(x, u, v) = \frac{\partial F}{\partial x}(x, u, v) = (0, 0)\} = \{(0, v): v \in R, 0\}$$

For the second component of $B(F)$ we have

$$\begin{cases} F(x_1, u, v) = F(x_2, u, v) \\ \frac{\partial F}{\partial x}(x_1, u, v) // \frac{\partial F}{\partial x}(x_2, u, v) \end{cases} \iff \begin{cases} (x_1^2, x_1^5 + ux_1^3 + vx) = (x_2^2, x_2^5 + ux_2^3 + vx) \\ (2x_1, 5x_1^4 + 3ux_1^2 + v) // (2x_2, 5x_2^4 + 3ux_2^2 + v) \end{cases}$$

The first equation yields $x_2 = -x_1$ and $v + ux_1^2 + x_1^4 = 0$. This with the second equation give $u = x_1^4$ and $v = -2x_1^2$. Thus $B(F) = \{(0, v): v \in R\} \cup \{(v^2, -2v): v \leq 0\}$ (figure 4.4.2).

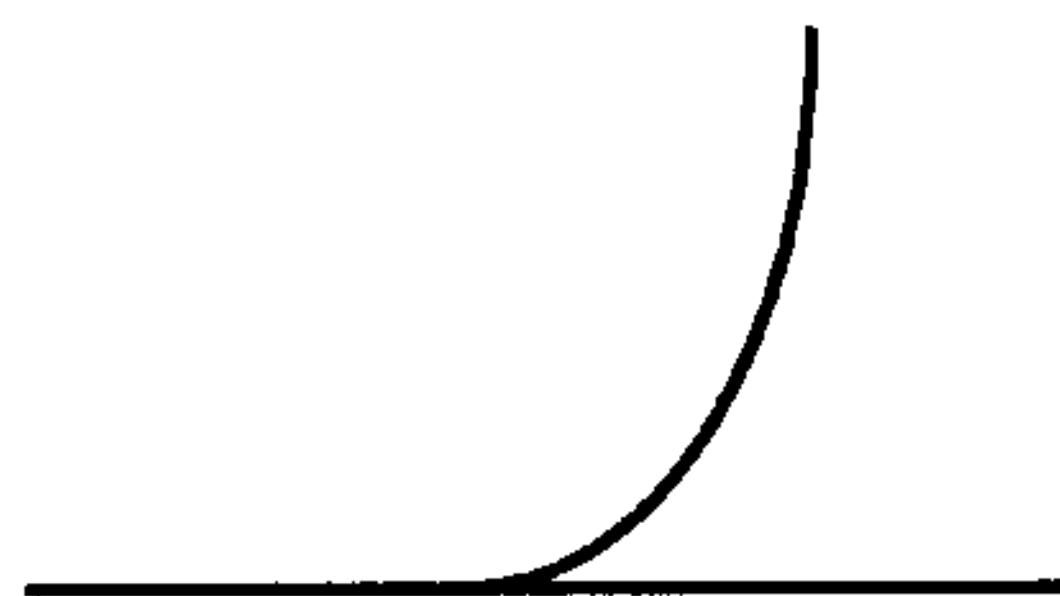

Figure 4.4.2

When considering a 3-parameter versal unfolding $\tilde{F}(x, u, v, w) = (x^2, x^5 + ux^3 + vx)$, the bifurcation of \tilde{F} is locally the product of $B(F)$ (above) by the line $(0, 0, w)$. We seek to find the generic section on $B(\tilde{F})$. To simplify the calculations, we take a diffeomorphic set B to $B(\tilde{F})$ with

$$B = \{(u, v, 0) : u, v \in R\} \cup \{(u, v, v^2) : u, v \in R, v \geq 0\}$$

We use J.W.Bruce's method described in [B1] to find the stratified Morse functions on B up to topological equivalence. We recall some definitions and results in [B1].

5.4.4. Definition : (1.5 in [B1]). Let $\mathcal{S} = (\cup S)$ be a semialgebraic stratification.

(a). A generalised tangent space at a point $x \in S$ is any plane of the form $T = \lim_{i \rightarrow \infty} T_{x_i} S_1$ where x_i lies on the stratum S_1 and $\lim_{i \rightarrow \infty} x_i = x$.

(b) A smooth function $h : R^n \rightarrow R$ is said to be Morse on \mathcal{S} if

(i). h is proper on the closure of each stratum S and the critical values of h on all the strata are distinct.

(ii). For each stratum S the restriction of h to S has only isolated non-degenerate critical points.

(iii). For each critical point $x \in S$ and each generalised tangent space T at x the restriction of the differential of $dh(x)$ to T has maximal rank, except for the single case $T = T_x S$.

For $x \in S$ consider the set of forms in $T_x^* R^n$ which are zero on some generalised tangent plane T . Taking the corresponding projective space P , and assuming the stratification is semi-algebraic we obtain a semi-algebraic subset Δ of P of positive codimension. Let $p : T_x R^n \rightarrow T_x R^n / T_x S$ be the natural projection. It induces a map $p^* : (T_x R^n / T_x S)^* \rightarrow (T_x R^n)^*$. Let $\Delta_1 = (p^*)^{-1}(\Delta)$ and $T^* = (T_x R^n / T_x S)^*$.

5.4.5. Proposition : (1.6 in [B1]). Let $h_0, h_1 : R^n \rightarrow R$ be smooth Morse functions for \mathcal{S} and suppose further at some point $x \in S$ either

(a). h_0 and h_1 are both submersions or

(b). h_0 and h_1 have non-degenerate singularities of the same index and viewing $dh_0(x), dh_1(x)$ as elements of T^* they both lie in the same component of $P(T^* - \Delta_1)$. □

Now back to our case. Let \mathcal{S} be a Whitney stratification of R^3 at the origin as follows, $\mathcal{S} = S \cup S_1 \cup S_2 \cup S_3 \cup S_4$ with $S = \{(x, 0, 0) : x \in R\}$, $S_1 = \{(x, y, 0) : x, y \in R, y < 0\}$, $S_2 = \{(x, y, 0) : x, y \in R, y > 0\}$, $S_3 = \{(x, y, y^2) : x, y \in R, y > 0\}$ and $S_4 = R^3 - S \cup S_1 \cup S_2 \cup S_3$. The only generalised tangent space at $(0, 0, 0) \in S$ is the plane $z = 0$, and the Morse functions on B are of the form $\pm x^2 + ay + bz$, so that each function is represented in $p(T^*)$ by $(a; b)$. The bad set Δ_1 is the point $(0; 1)$ in $p(T^*)$. Therefore $p(T^* - \Delta_1)$ has one component, and all Morse functions on B are topologically equivalent to $\pm x^2 + y$.

The preimages of 0 by the functions $h_1(u, v, w) = +u^2 + v$ and $h_2(u, v, w) = -u^2 + v$ are the product of the parabolae $v = \mp u^2$ by the w -axis (figure 4.4.3).

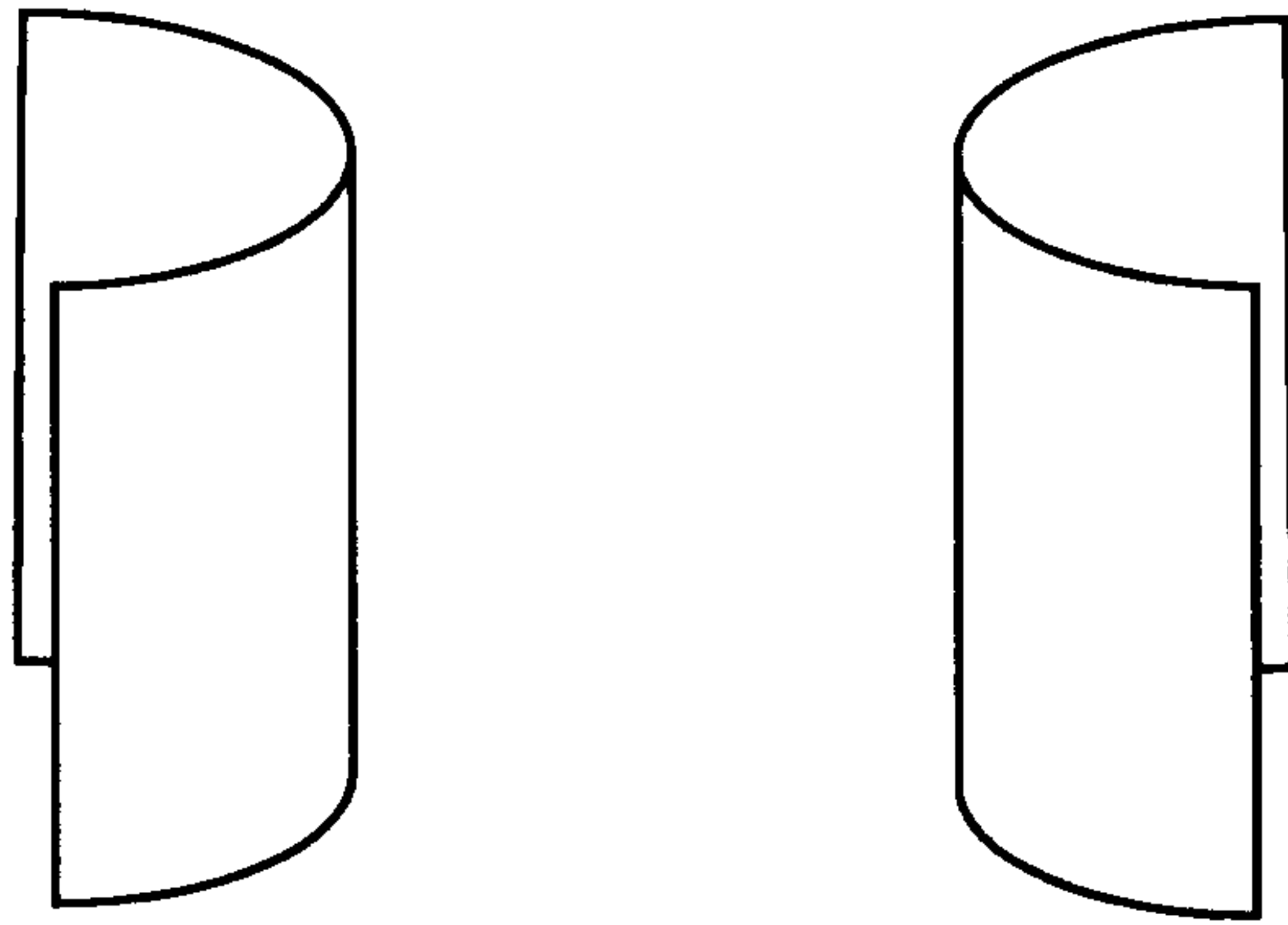

Figure 4.4.3

The fibres of the functions h_1 and h_2 are $B \cap h_i^{-1}(c)$, $i = 1, 2$ with c a constant near the origin. We can realise $h_i^{-1}(c)$ by moving the above big parabolae along the v -axis. We take their intersections with B and obtain the following transitions (figure 4.4.4), where the thick curves are the intersections of $h_i^{-1}(c)$ with the set $\{(u, v, v^2) : u, v \in \mathbb{R}, v > 0\}$ and the other curve is the intersection of $h_i^{-1}(c)$ with the plane $w = 0$.

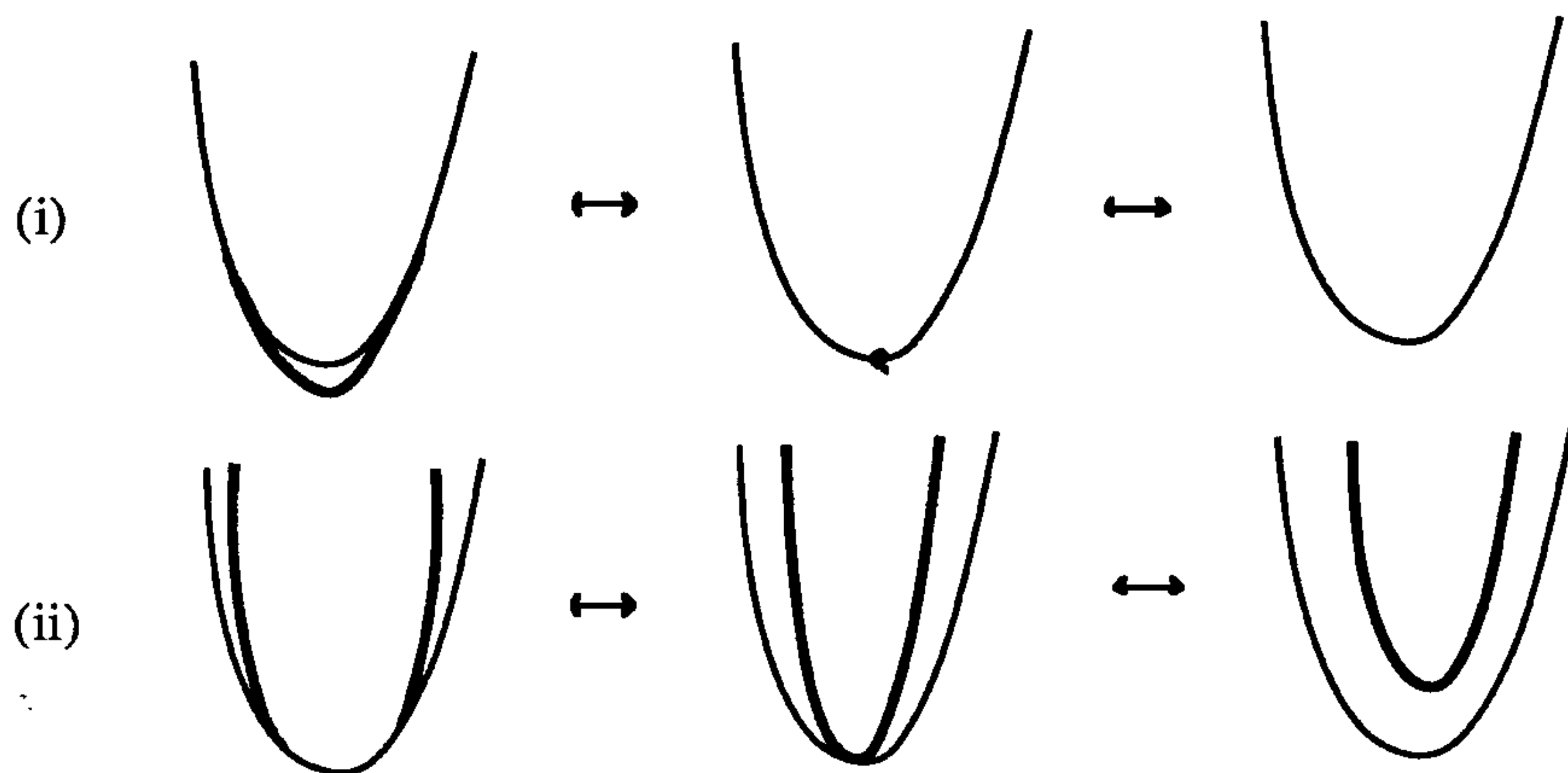

Figure 4.4.4

Chapter 5

Rotational Symmetry in the Plane

§1. Introduction

We have considered in the previous chapter the reflexional symmetry of plane curves. It is natural to look for a corresponding theory to investigate local *rotational* symmetry of plane curves, and we present one possible approach in this chapter. We consider a smooth unit speed curve $\gamma: I \rightarrow R^2$ where I is a smooth interval of R or $I = S^1$. For purpose of calculations, we sometimes identify the target R^2 with the set of complex numbers. The basic idea is to look for centres of local rotational symmetry in the sense of centres C for which there is a rotation about C taking a point $\gamma(t_1)$, together with its tangent line and its *centre of curvature*, to $\gamma(t_2)$ together with its tangent line and its centre of curvature. The locus of such centres C is called the *rotational symmetry set* (RSS).

Two distinguishable cases arise naturally from the choice of an orientation on γ . The first case is when the rotation takes the tangent vector $T(t_1)$ to the tangent vector $T(t_2)$, and the second case is when $T(t_1)$ is rotated to $-T(t_2)$. In the first case the locus of the centres C is denoted by RSS^+ and in the second RSS^- . It turns out that RSS^+ is locally a subset of the set of critical values of C^+ , a map from the plane to the plane. In some cases where it is the critical set of the map C^+ , it is possible to apply the results in Chapter 3 and describe rigorously the local structure of RSS^+ and its generic transitions in 1-parameter families of curves γ . The set RSS^- is locally described as part of the discriminant of C^- , a symmetric map from the plane to the plane. It is a very striking fact that the local structure of the rotational symmetry sets, including that in 1-parameter families, closely resembles the local structure of the duals of the symmetry set.

I am much indebted here to the inspirational computer pictures of Richard Morris [M], which constantly suggested new things to prove as well as illustrating those already proved. Here is a brief summary of the technique for drawing the rotational symmetry set RSS^+ of a given curve detailed in [M]. This technique led to a fast algorithm for drawing the symmetry set.

As detailed in §3, we are essentially looking for pairs of points (t_1, t_2) on the curve γ at which the curvatures are equal: $\kappa(t_1) = \kappa(t_2)$. A simple construction gives the centre C^+ for every such pair. Drawing the graph of curvature (figure 5.1.1) we are looking for all pairs of points at the same level on the graph. This is done by starting at a maximum or minimum (corresponding to a vertex of γ) and working from there, keeping track of when one value, t_1 or t_2 , has to turn round because the other has reached another maximum or minimum (figure 5.1.1 (ii)). Eventually these pairs

(t_1, t_2) converge on another maximum or minimum and end with a pair of the form (t_1, t_1) . There are also some closed paths in the set $S = \{(t_1, t_2) : \kappa(t_1) = \kappa(t_2)\}$. These have no natural starting point. Such a path is suggested in (figure 5.1.1 (iii)).

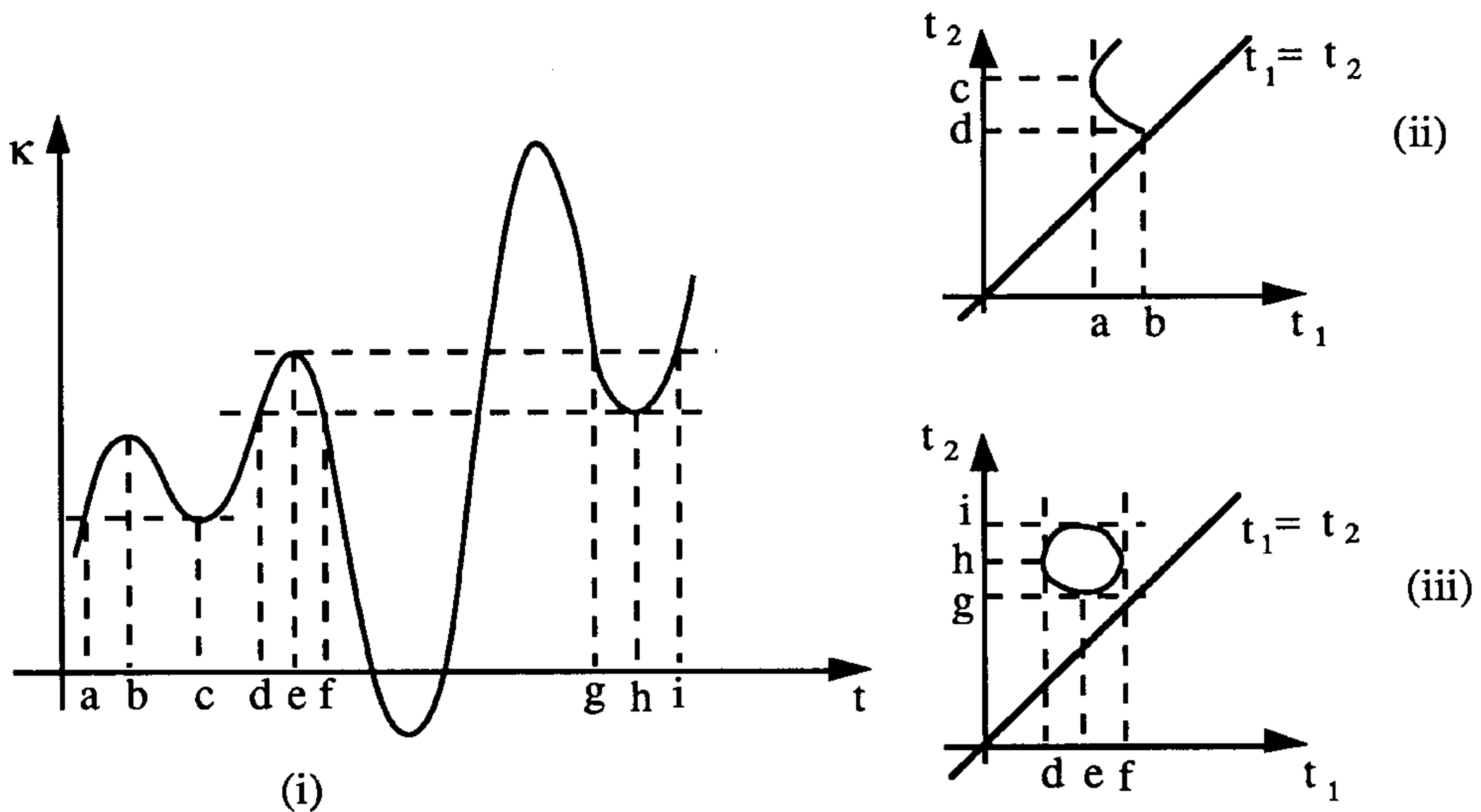

Figure 5.1.1

A somewhat similar idea works for the symmetry set: starting at a vertex of γ we calculate pairs of points of contact of bitangent circles which diverge from this vertex and keep track of them until they converge at another vertex. Again there are exceptional, closed pieces which do not arise this way. Both algorithms have been fully implemented in Fortran by Richard Morris [M].

This chapter is organized as follows. In section 2 we define the *centre maps* C^\pm and give the formalised definition of the rotational symmetry set. We then explore in section 3 the local structure of RSS^+ and its generic transitions in 1-parameter families of curves γ . The RSS^- is dealt with in section 4.

§2. The centre maps

Let $\gamma: I \rightarrow R^2$ be, as usual, an embedded smooth curve, where I is either an open interval of R or else the unit circle. Consider two points $\gamma(t_1), \gamma(t_2)$ at which the (unit) tangent vectors are $T(t_1), T(t_2)$ and the unit normal vectors are $N(t_1), N(t_2)$ respectively. We seek two points $C^\pm = C^\pm(t_1, t_2)$ which are the centres of rotation taking $\gamma(t_1)$ to $\gamma(t_2)$ and $T(t_1)$ to $\pm T(t_2)$. Hence in each case the tangent line at $\gamma(t_1)$ is taken to that at $\gamma(t_2)$. Using the complex numbers \mathbf{C} to parametrize R^2 and writing θ for the angle of rotation, we have

$$\gamma(t_2) - C^\pm = e^{i\theta}(\gamma(t_1) - C^\pm) \quad \text{and} \quad T(t_2) = \pm T(t_1)e^{i\theta}$$

It follows that the *centre maps* are given by

$$C^\pm(t_1, t_2) = \frac{\gamma(t_2)T(t_1) \mp \gamma(t_1)T(t_2)}{T(t_1) \mp T(t_2)} \in \mathbf{C}, \quad (1)$$

provided $T(t_1) \neq \pm T(t_2)$ (figure 5.2.1).

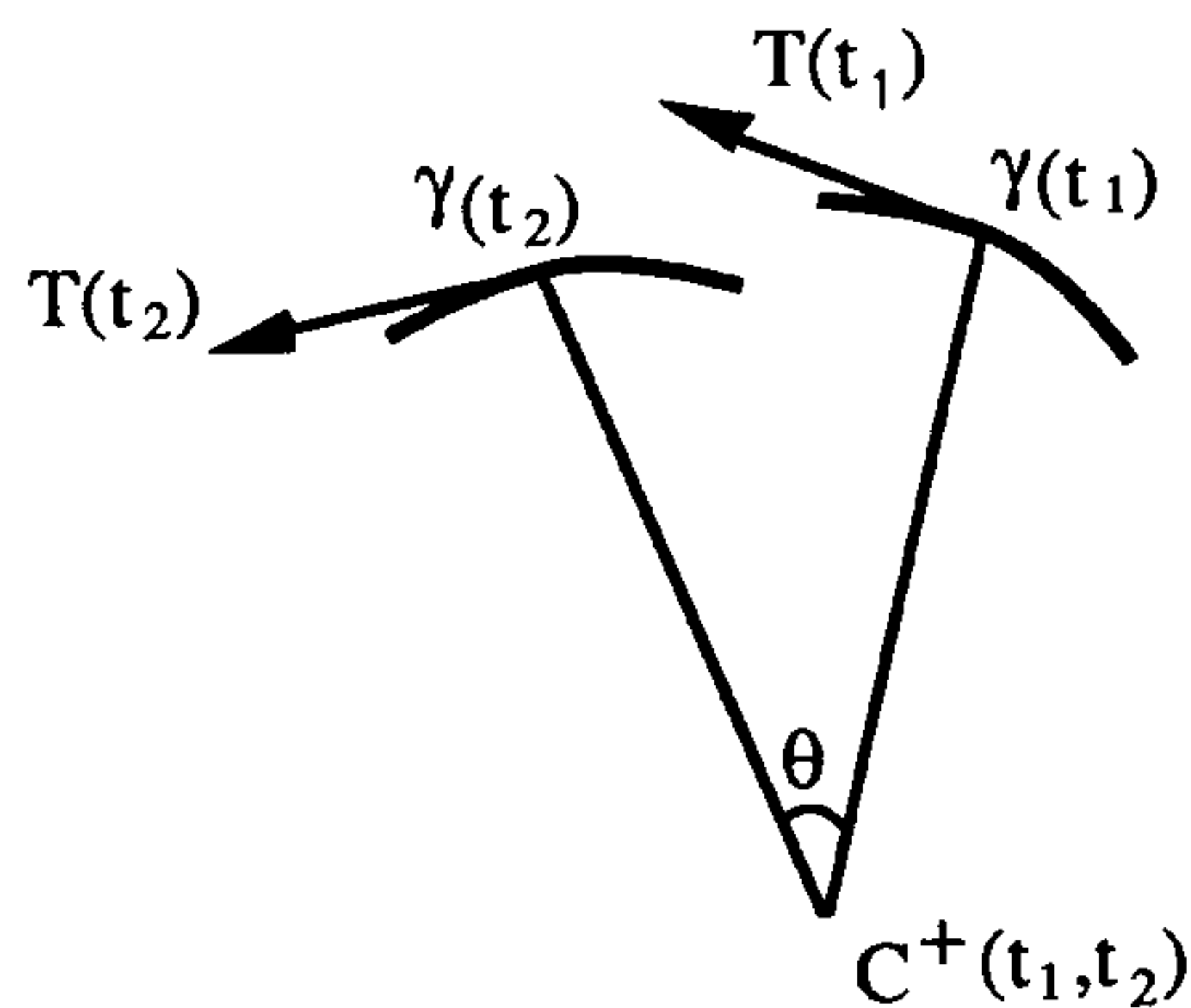

Figure 5.2.1

An interesting limiting case occurs for C^+ when t_1 and t_2 both tend to the same value t . We assume that $\gamma(t)$ is not an inflexion on the curve γ .

5.2.1. Lemma : *The limit of $C^+(t_1, t_2)$ when t_1 and t_2 both tend to t is $e(t)$, where $e(t)$ is the centre of curvature of γ at $\gamma(t)$.*

Proof: We denote by $\bar{T}(t)$ the complex conjugate of $T(t)$. If $T(t_2) = e^{i\theta}T(t_1)$ then $\bar{T}(t_2) = e^{-i\theta}\bar{T}(t_1)$. We have

$$\begin{aligned}
C^+(t_1, t_2) &= \frac{\gamma(t_2)T(t_1) - \gamma(t_1)T(t_2)}{T(t_1) - T(t_2)} \\
&= \frac{[\gamma(t_2)T(t_1) + \gamma(t_1)T(t_2)][\overline{T}(t_1) - \overline{T}(t_2)]}{[T(t_1) - T(t_2)][\overline{T}(t_2) - \overline{T}(t_1)]} \\
&= \frac{\gamma(t_1) + \gamma(t_2) + e^{-i\theta}\gamma(t_1) - e^{-i\theta}\gamma(t_2)}{(e^{i\theta} - 1)(e^{-i\theta} - 1)} \\
&= \frac{(1 - \cos\theta)(\gamma(t_1) + \gamma(t_2)) + i\sin\theta(\gamma(t_2) - \gamma(t_1))}{2(1 - \cos\theta)} \\
&= \frac{1}{2}(\gamma(t_1) + \gamma(t_2)) + \frac{i}{2} \frac{\sin\theta}{(1 - \cos\theta)}(\gamma(t_2) - \gamma(t_1)) \\
&= \frac{1}{2}(\gamma(t_1) + \gamma(t_2)) + \frac{i}{2} \frac{\cos\frac{\theta}{2}}{\sin\frac{\theta}{2}}(\gamma(t_2) - \gamma(t_1))
\end{aligned}$$

If we fix a line ℓ in the plane, the angle of rotation θ is the difference between the angles $\psi(t_2) = \text{angle}[T(t_2), \ell]$ and the angle $\psi(t_1) = \text{angle}[T(t_1), \ell]$ as shown in (figure 5.2.2).

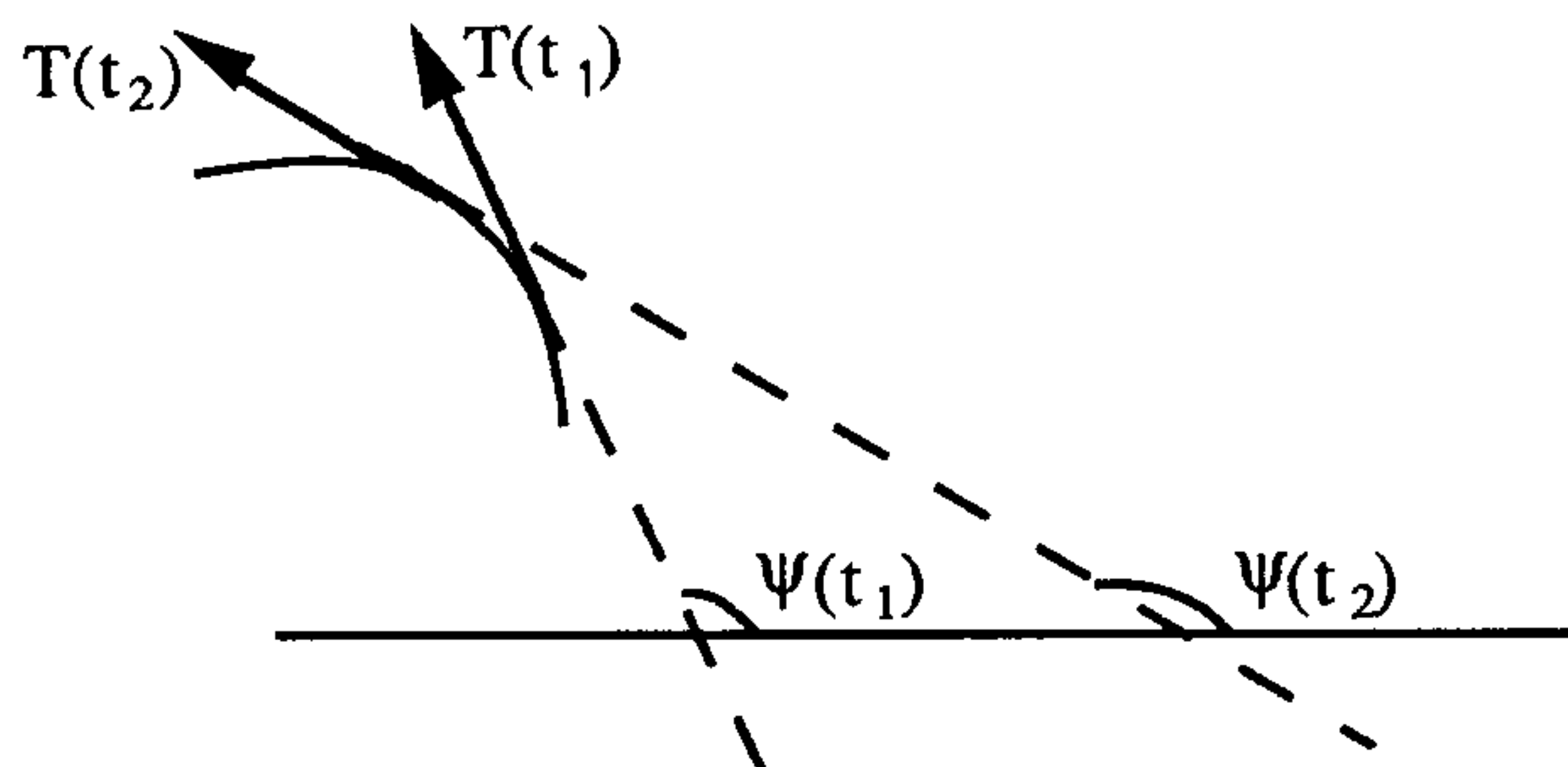

Figure 5.2.2

We know that for unit speed curves

$$\lim_{t_1, t_2 \rightarrow t} \frac{\psi(t_2) - \psi(t_1)}{t_2 - t_1} = \psi'(t) = \kappa(t)$$

Hence,

$$\begin{aligned}
\lim_{t_1, t_2 \rightarrow t} (\gamma(t_2) - \gamma(t_1)) \frac{1}{\sin \frac{\theta}{2}} &= \lim_{t_1, t_2 \rightarrow t} \frac{\gamma(t_2) - \gamma(t_1)}{t_2 - t_1} \cdot \frac{t_2 - t_1}{\theta} \cdot \frac{2 \frac{\theta}{2}}{\sin \frac{\theta}{2}} \\
&= 2 \lim_{t_1, t_2 \rightarrow t} \frac{\gamma(t_2) - \gamma(t_1)}{t_2 - t_1} \cdot \frac{t_2 - t_1}{\psi(t_2) - \psi(t_1)} \cdot \frac{\frac{\theta}{2}}{\sin \frac{\theta}{2}} \\
&= \frac{2}{\kappa(t)} T(t)
\end{aligned}$$

It follows that

$$\lim_{t_1, t_2 \rightarrow t} C^+(t_1, t_2) = \gamma(t) + \frac{i}{\kappa(t)} T(t) = \gamma(t) + \frac{1}{\kappa(t)} N(t) = e(t) \square$$

We extend the map C^+ on the diagonal and define

$$C^+(t, t) = e(t) \tag{2}$$

The resulting C^+ is still smooth. On the other hand there is no point in extending C^+ to parallel tangents, *i.e.*, $T(t_1) = T(t_2)$ and $\gamma(t_1) \neq \gamma(t_2)$, for that merely gives $C^+ = \infty$.

There is no difficulty interpreting $C^-(t, t)$: it is merely $\gamma(t)$. We do not extend C^- to the case $T(t_1) = -T(t_2)$ since again that gives $C^- = \infty$. We can now check the following.

5.2.2. Lemma : *Rotation about $C^\pm(t_1, t_2)$ through θ takes $e(t_1)$ to $e(t_2)$ if and only if $\kappa(t_1) = \pm \kappa(t_2)$.*

Proof: Rotation about $C^\pm(t_1, t_2)$ through θ takes $e(t_1)$ to $e(t_2)$ if and only if

$$e(t_2) - C^\pm = e^{i\theta} (e(t_1) - C^\pm)$$

Substituting $e(t)$ by $\gamma(t) + \frac{1}{\kappa(t)} N(t)$ yields

$$\gamma(t_2) + \frac{1}{\kappa(t_2)} N(t_2) - C^\pm = e^{i\theta} \left(\gamma(t_1) + \frac{1}{\kappa(t_1)} N(t_1) - C^\pm \right)$$

That is

$$\gamma(t_2) - C^\pm + \frac{1}{\kappa(t_2)} N(t_2) = e^{i\theta} (\gamma(t_1) - C^\pm) + \frac{1}{\kappa(t_1)} e^{i\theta} N(t_1) \tag{*}$$

The point C^\pm is also the centre of rotation which takes $\gamma(t_1)$ to $\gamma(t_2)$ and $N(t_1)$ to $N(t_2)$. Hence $\gamma(t_2) - C^\pm = e^{i\theta} (\gamma(t_1) - C^\pm)$ and $N(t_2) = \pm e^{i\theta} N(t_1)$. Therefore the equation (*) holds if and only if $\kappa(t_1) = \pm \kappa(t_2)$. \square

5.2.3. Definition : *The Rotational Symmetry Set (RSS) consists of two parts, RSS^+ and RSS^- :*

$$RSS^\pm = \{C^\pm(t_1, t_2) : \kappa(t_1) = \pm\kappa(t_2)\},$$

where we use C^+ in the form extended by (2). (See figure 5.2.3 for an example of RSS^+).

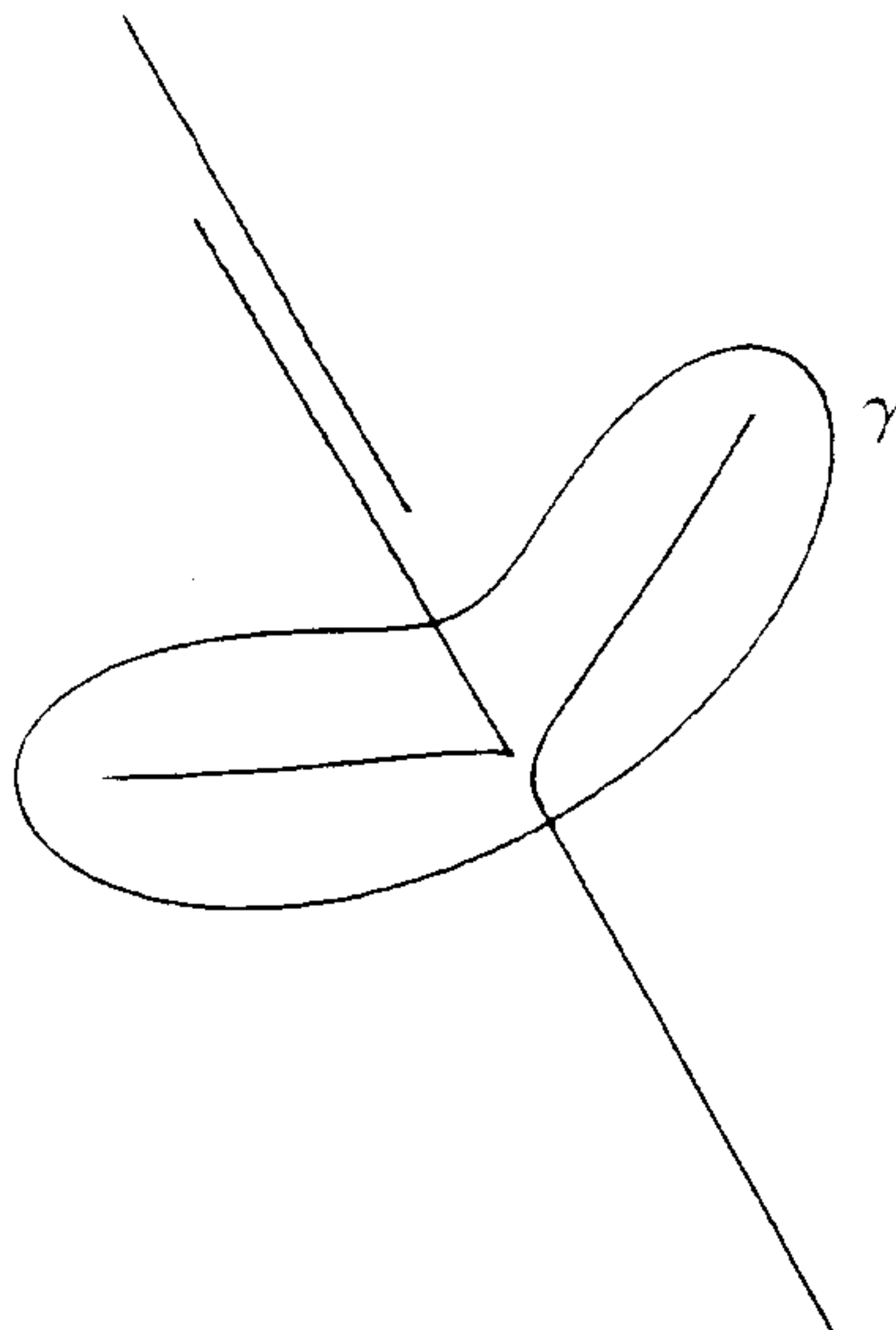

Figure 5.2.3. A rotational symmetry set (RSS^+)

5.2.4. Remarks : (1) If $C^+(t_1, t_2) \in RSS^+$ for sequences of points $t_1 \rightarrow t$, $t_2 \rightarrow t$ then $\gamma(t)$ is a *vertex* of $\gamma : \kappa'(t) = 0$. Thus RSS^+ contains the centre of curvature at each vertex of γ . Note that the symmetry set also contains these points.

(2) $C^-(t, t) \in RSS^-$ requires $\kappa(t) = 0$, *i.e.*, γ has an inflexion at $\gamma(t)$, and then $C^-(t, t) = \gamma(t)$. Thus RSS^- contains all the inflexion points of γ .

(3) The angle of rotation θ has been suppressed above. We have not so far attempted to include it in a coherent theory.

§3. The RSS^+

For the time being, let us consider RSS^+ . Not only is RSS^+ the image by C^+ of $\{(t_1, t_2) : \kappa(t_1) = \kappa(t_2)\}$, but we have the following result.

5.3.1. Proposition : *The set of critical values of C^+ is precisely $RSS^+ \cup SSE$, the union of RSS^+ , the symmetry set and the evolute of γ . Note that the last arises as the image of the diagonal $\{(t, t)\}$ under C^+ .*

Proof: We differentiate the map C^+ and obtain

$$\frac{\partial C^+}{\partial t_1}(t_1, t_2) = \frac{\kappa(t_1)N(t_1)T(t_2)(\gamma(t_1) - \gamma(t_2))}{(T(t_1) - T(t_2))^2} - \frac{T(t_1)T(t_2)}{T(t_1) - T(t_2)}$$

$$\frac{\partial C^+}{\partial t_2}(t_1, t_2) = -\frac{\kappa(t_2)N(t_2)T(t_1)(\gamma(t_1) - \gamma(t_2))}{(T(t_1) - T(t_2))^2} + \frac{T(t_1)T(t_2)}{T(t_1) - T(t_2)}$$

If we write $\frac{\partial C^+}{\partial t_1}(t_1, t_2) = A + iB$ and $\frac{\partial C^+}{\partial t_2}(t_1, t_2) = C + iD$, then the differential map DC^+ of C^+ fails to be an isomorphism at (t_1, t_2) if and only if the

matrix $\begin{pmatrix} A & C \\ B & D \end{pmatrix}$ has zero determinant. That is $AD - BC = 0$, and equivalently

$Im(\frac{\partial C^+}{\partial t_1}(t_1, t_2) \cdot \frac{\partial C^+}{\partial t_2}(t_1, t_2)) = 0$. (Here $Im(z)$ denotes the imaginary part of the complex number z .) Thus, the critical set of the map C^+ is

$$\Sigma_{C^+} = \{(t_1, t_2) : Im(\frac{\partial C^+}{\partial t_1}(t_1, t_2) \cdot \frac{\partial C^+}{\partial t_2}(t_1, t_2)) = 0\}$$

Calculation show that

$$Im(\frac{\partial C^+}{\partial t_1}(t_1, t_2) \cdot \frac{\partial C^+}{\partial t_2}(t_1, t_2)) = Im\left\{ \frac{i}{\|(T(t_1) - T(t_2))^2\|} \times \right. \\ \left. [\kappa(t_1)(\gamma(t_1) - \gamma(t_2))\overline{(T(t_1) - T(t_2))} - \kappa(t_2)(\gamma(t_1) - \gamma(t_2))(T(t_1) - T(t_2))] \right\}$$

Therefore,

$$Im(\frac{\partial C^+}{\partial t_1}(t_1, t_2) \cdot \frac{\partial C^+}{\partial t_2}(t_1, t_2)) = 0 \iff \begin{cases} t_1 = t_2 & \text{or} \\ \kappa(t_1) = \kappa(t_2) & \text{or} \\ Real[(\gamma(t_1) - \gamma(t_2))\overline{(T(t_1) - T(t_2))}] = 0 \end{cases}$$

If we consider γ as a real plane curve, then the condition $Real[(\gamma(t_1) - \gamma(t_2))\overline{(T(t_1) - T(t_2))}] = 0$ says that the scalar product of the two vectors $(\gamma(t_1) - \gamma(t_2))$ and $(T(t_1) - T(t_2))$ is zero. We write $(\gamma(t_1) - \gamma(t_2)) \cdot (T(t_1) - T(t_2)) = 0$. This is exactly the necessary and sufficient condition for the existence of a bitangent circle to the curve γ at $\gamma(t_1)$ and $\gamma(t_2)$ when γ has a coherent orientation with respect to the circle at $\gamma(t_1)$ and $\gamma(t_2)$. Thus

$$C^+(\Sigma_{C^+}) = RSS^+ \cup SS \cup E$$

□

The SS has been extensively studied and so has the evolute. In this chapter we are mainly interested in the structure of RSS^+ and its generic transitions when considering 1-parameter families of curves γ . There are three cases to consider. The first case is when the critical locus is locally the RSS^+ . The RSS^+ is then the discriminant of a map from the plane to the plane. The results in Chapter 3 provide

a method of recognition of the singularities of RSS^+ . The second case is when it is locally the union of the RSS^+ and the SS , and the last case is when it is locally the union of RSS^+ , SS and E . The last two cases are difficult to deal with rigorously, for the centre map C^+ is very degenerate and we lack of a recognition criterion for degenerate maps from the plane to the plane. We shall adopt a more descriptive approach when we deal with them.

I. The simple case where RSS^+ does not cross the symmetry set or the evolute

Suppose that $p_0 = C^+(t_1^0, t_2^0) \in RSS^+$. The situation is considerably simplified when $p_0 \notin SS$ and $p_0 \notin E$ (so $t_1^0 \neq t_2^0$), for then RSS^+ is locally the discriminant of C^+ : a map from the plane to the plane. In fact it is not hard to find the conditions for the map C^+ to have a fold, cusp, swallowtail, lips and beaks singularity at p_0 using the results in Chapter 3. For we need information on the critical set $\Sigma^+ = \{(t_1, t_2): \kappa(t_1) = \kappa(t_2)\}$. A simple calculation on the function $\kappa(t_1) - \kappa(t_2)$ shows that

(i). The set Σ^+ is locally smooth if and only if $\kappa'(t_1^0) \neq 0$ or $\kappa'(t_2^0) \neq 0$.

(ii). In the case $\kappa'(t_1^0) = \kappa'(t_2^0) = 0$ the set Σ^+ is locally an isolated point if $\kappa''(t_1^0)\kappa''(t_2^0) < 0$, and a crossing if $\kappa''(t_1^0)\kappa''(t_2^0) > 0$.

When the set Σ is smooth, it is given locally as a graph of a function parametrized by either t_1 or t_2 . Without loss of generality, we assume that $\kappa(t_2^0) \neq 0$ and Σ^+ is locally the graph of a function ϕ with $\phi'(t_1^0) = \frac{\kappa'(t_1^0)}{\kappa'(t_2^0)}$. That is $\Sigma^+ = \{(t_1, \phi(t_1)): t_1 \in I, t_1^0\}$. The rotational symmetry set RSS^+ is then parametrized by $r(t_1) = C^+(t_1, \phi(t_1))$. The order of the vanishing of the successive derivatives of r at t_1^0 reflects the order of contact of the critical set Σ^+ with the kernel line of the differential map of C^+ at p_0 . This order of contact is expressed in terms of the successive derivatives of κ at the two points t_1^0 and t_2^0 . Using Propositions 3.2.4 and 3.3.2 in Chapter 3 we deduce the following.

5.3.2. Proposition : *The map C^+ is locally at p_0 a*

(i). *Fold map if and only if $\kappa'(t_1^0) \neq \kappa'(t_2^0)$.*

(ii) *Cusp map if and only if $\kappa'(t_1^0) = \kappa'(t_2^0)$, $\kappa''(t_1^0) \neq \kappa''(t_2^0)$.*

(iii) *A swallowtail map if and only if $\kappa'(t_1^0) = \kappa'(t_2^0)$, $\kappa''(t_1^0) = \kappa''(t_2^0)$, $\kappa'''(t_1^0) \neq \kappa'''(t_2^0)$.*

Proof: The proof is a matter of calculating successive derivatives of the map $r(t_1) = C^+(t_1, \phi(t_1))$ at t_1^0 . We recall from the proof of Proposition 5.3.1 that

$$\begin{aligned}\frac{\partial C^+}{\partial t_1}(t_1, t_2) &= \frac{\kappa(t_1)N(t_1)T(t_2)(\gamma(t_1) - \gamma(t_2))}{(T(t_1) - T(t_2))^2} - \frac{T(t_1)T(t_2)}{T(t_1) - T(t_2)} \\ &= \frac{T(t_1)T(t_2)}{(T(t_1) - T(t_2))^2} [i\kappa(t_1)(\gamma(t_1) - \gamma(t_2)) - T(t_1) + T(t_2)]\end{aligned}$$

If $\kappa(t_1) \neq 0$ in a neighbourhood of t_1^0 , then

$$\frac{\partial C^+}{\partial t_1}(t_1, t_2) = i\kappa(t_1) \frac{T(t_1)T(t_2)}{(T(t_1) - T(t_2))^2} [\gamma(t_1) + \frac{1}{\kappa(t_1)}N(t_1) - \gamma(t_2) - \frac{1}{\kappa(t_1)}N(t_2)]$$

At a point $(t_1, \phi(t_1))$ we have $\kappa(t_1) = \kappa(\phi(t_1))$ and

$$\frac{\partial C^+}{\partial t_1}(t_1, \phi(t_1)) = i\kappa(t_1) \frac{T(t_1)T(t_2)}{(T(t_1) - T(t_2))^2} [e(t_1) - e(\phi(t_1))] \quad (*)$$

The vector $\frac{\partial C^+}{\partial t_1}(t_1^0, t_2^0)$ is zero when $e(t_1^0) = e(t_2^0)$. In this case there is a biosculating circle to the curve γ at $\gamma(t_1^0)$ and $\gamma(t_2^0)$, and the critical values of the map C^+ is the union of RSS^+ and SS . For the simple case when the critical values of C^+ is the RSS^+ the vector $\frac{\partial C^+}{\partial t_1}(t_1^0, t_2^0)$ is non-zero and the map C^+ is of rank 1 at (t_1^0, t_2^0) .

When $\kappa(t_1^0) = 0$ we have $\frac{\partial C^+}{\partial t_1}(t_1^0, t_2^0) = -\frac{T(t_1^0)T(t_2^0)}{T(t_1^0) - T(t_2^0)}$. This is a non-zero vector, and again the map C^+ is of rank 1 at (t_1^0, t_2^0) .

At $(t_1, \phi(t_1))$ we have $\frac{\partial C^+}{\partial t_2}(t_1, \phi(t_1)) = -\frac{\partial C^+}{\partial t_1}(t_1, \phi(t_1))$ and $\phi'(t_1) = \frac{\kappa'(t_1)}{\kappa'(\phi(t_1))}$. Therefore

$$r'(t_1) = [1 - \frac{\kappa'(t_1)}{\kappa'(\phi(t_1))}] \frac{\partial C^+}{\partial t_1}(t_1, \phi(t_1)) \quad (**)$$

The map C^+ is locally a fold map if and only if $r'(t_1^0) \neq 0$ (Proposition 3.2.4), that is if and only if $\kappa'(t_1^0) \neq \kappa'(t_2^0)$.

Suppose that $r'(t_1^0) = 0$ then

$$r''(t_1^0) = -[\frac{\kappa''(t_1^0) - \kappa''(t_2^0)}{\kappa'(t_2^0)}] \frac{\partial C^+}{\partial t_1}(t_1^0, t_2^0)$$

The map C^+ is locally a cusp map if and only if $r'(t_1^0) = 0$ and $r''(t_1^0) \neq 0$ (Proposition 3.2.4). Equivalently $\kappa'(t_1^0) = \kappa'(t_2^0)$ and $\kappa''(t_1^0) \neq \kappa''(t_2^0)$.

When $r'(t_1^0) = r''(t_1^0) = 0$,

$$r'''(t_1^0) = -[\frac{\kappa'''(t_1^0) - \kappa'''(t_2^0)}{\kappa'(t_2^0)}] \frac{\partial C^+}{\partial t_1}(t_1^0, t_2^0)$$

The map C^+ is locally a swallowtail map if and only if $r'(t_1^0) = r''(t_1^0) = 0$ and $r'''(t_1^0) \neq 0$ (Proposition 3.3.2). Equivalently $\kappa'(t_1^0) = \kappa'(t_2^0)$, $\kappa''(t_1^0) \neq \kappa''(t_2^0)$ and $\kappa'''(t_1^0) \neq \kappa'''(t_2^0)$. \square

5.3.3. Corollary : *Locally at $p_0 = (t_0^0, t_2^0)$ the rotational symmetry set RSS^+*

(i) is a smooth curve if and only if $\kappa'(t_1^0) \neq \kappa'(t_2^0)$.

(ii) has a stable cusp if and only if $\kappa'(t_1^0) = \kappa'(t_2^0)$ and $\kappa''(t_1^0) \neq \kappa''(t_2^0)$.

(iii) undergoes for generic 1-parameter families of curves γ_s a swallowtail transition if and only if $\kappa'(t_1^0) = \kappa'(t_2^0)$, $\kappa''(t_1^0) = \kappa''(t_2^0)$, $\kappa'''(t_1^0) \neq \kappa'''(t_2^0)$.

Proof: (i) and (ii) follow from Proposition 5.3.2. For the statement (iii), we proved in Proposition 5.3.2 that the centre map C^+ is a swallowtail map. If we consider a 1-parameter family of curves γ_s (with $\gamma_0 = \gamma$) and the corresponding 1-parameter family of maps C_s^+ , then the family \tilde{C}^+ with $\tilde{C}^+(t_1, t_2, s) = C_s^+(t_1, t_2)$ is a versal unfolding of C_0^+ if and only if $\frac{\partial \tilde{C}^+}{\partial t_1}(t_1^0, t_2^0, 0)$ and $\frac{\partial \tilde{C}^+}{\partial s}(t_1^0, t_2^0, 0)$ are linearly independent. One can verify that this condition is satisfied by generic 1-parameter families of curves γ_s . Therefore for generic 1-parameter families of curves γ_s the discriminant of the family \tilde{C}^+ is a swallowtail and the RSS^+ undergoes a swallowtail transition. \square

When the RSS^+ is smooth or has an ordinary cusp, it is not difficult to compute the direction of its tangent line at the point $C^+(t_1^0, t_2^0)$ when $\gamma(t_1^0)$ and $\gamma(t_2^0)$ are not inflexion points on γ . With the equations (*) and (**), the tangent vector to the RSS^+ is

$$\begin{aligned} r'(t_1^0) &= (1 - \phi'(t_1^0)) \frac{\partial C^+}{\partial t_1}(t_1^0, t_2^0) \\ &= i \left(1 - \frac{\kappa'(t_1^0)}{\kappa'(t_2^0)}\right) \kappa(t_1^0) \frac{T(t_1^0)T(t_2^0)}{(T(t_1^0)T(t_2^0))^2} [e(t_1^0) - e(t_2^0)] \end{aligned}$$

If p_0 is a smooth point on the RSS^+ , then $(1 - \frac{\kappa'(t_1^0)}{\kappa'(t_2^0)}) \kappa(t_1^0) \frac{T(t_1^0)T(t_2^0)}{(T(t_1^0)T(t_2^0))^2}$ is a non-zero real number and the vector $r'(t_1^0)$ has the direction of $i[e(t_1^0) - e(t_2^0)]$. The vector $i[e(t_1^0) - e(t_2^0)]$ is perpendicular to the segment $[e(t_1^0), e(t_2^0)]$.

When p_0 is an ordinary cusp on the RSS^+ , the limiting direction of the tangent to the RSS^+ at p_0 is the direction of $r''(t_1^0)$. We recall from the proof of Proposition 5.2.2 that $r''(t_1^0)$ has the same direction as $\frac{\partial C^+}{\partial t_1}(t_1^0, t_2^0)$, that is that of $i[e(t_1^0) - e(t_2^0)]$.

In both cases $C^+(t_1^0, t_2^0)$ is the centre of rotation which takes $e(t_1^0)$ to $e(t_2^0)$. It follows that:

5.3.4. Corollary : *The tangent line to the RSS^+ at a smooth point and at an ordinary cusp is the perpendicular bisector to the segment $[e(t_1^0), e(t_2^0)]$ (figure 5.3.1).* \square

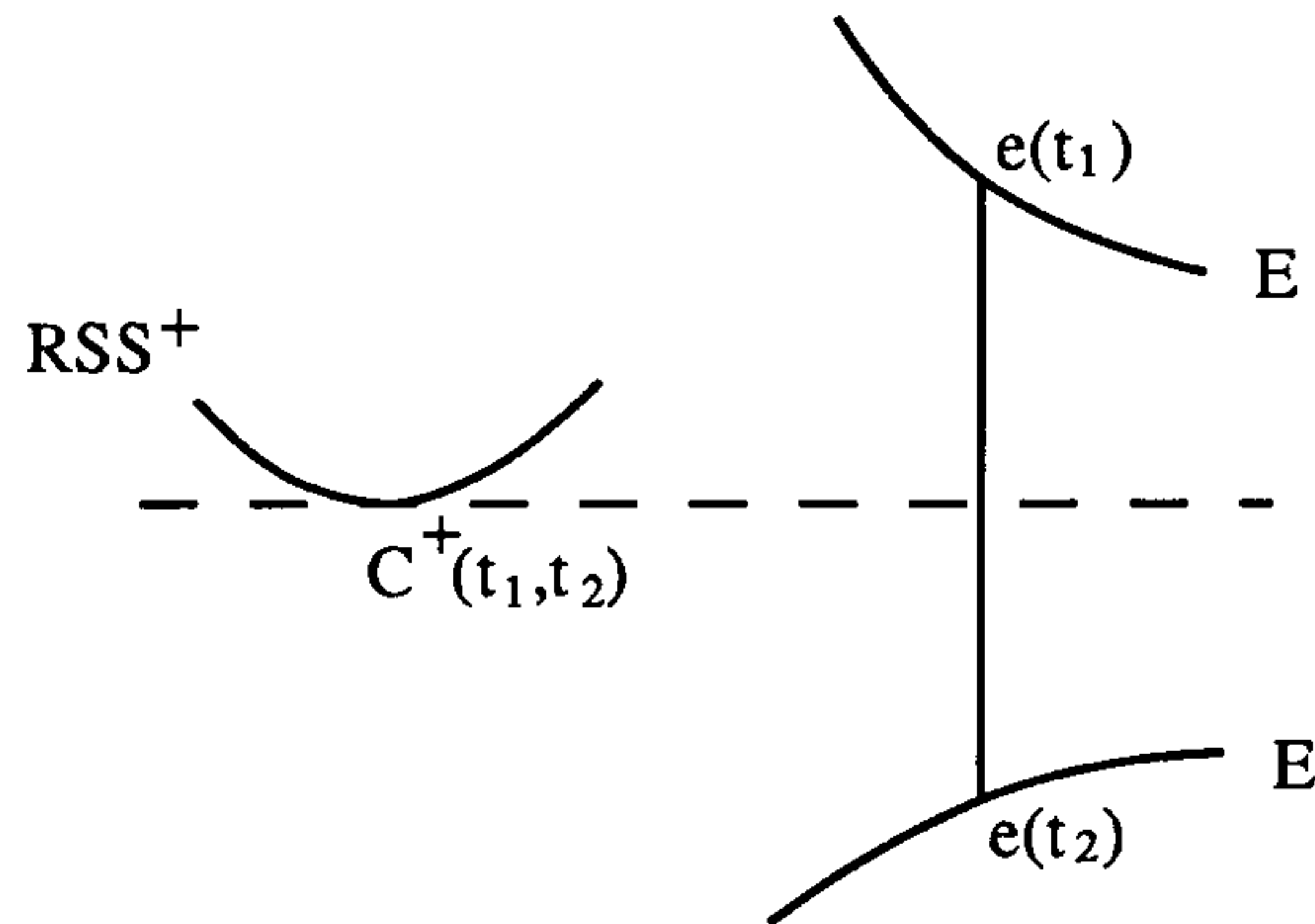

Figure 5.3.1

We still assume that the critical set of the map C^+ is locally $\Sigma^+ = \{(t_1, t_2): \kappa(t_1) = \kappa(t_2)\}$. An interesting feature on smooth points on the RSS^+ is the inflexions. These occur when the curvature function of the RSS^+ vanishes. If we write $r(t_1) = C^+(t_1, \phi(t_1)) = X + iY$ with X and Y smooth real functions in t_1 , then the curvature of RSS^+ , denoted by ρ , is given by

$$\rho(t_1) = \frac{X'Y'' - X''Y'}{(X'^2 + Y'^2)^{\frac{3}{2}}}(t_1)$$

The function ρ vanishes at t_1^0 when $(X'Y'' - X''Y')(t_1^0) = 0$. Equivalently $\bar{r}'(t_1^0)r''(t_1^0)$ is real. We have $r'(t_1) = (1 - \phi'(t_1))\frac{\partial C^+}{\partial t_1}(t_1, \phi(t_1))$. Thus

$$r''(t_1) = -\phi''(t_1)\frac{\partial C^+}{\partial t_1}(t_1, \phi(t_1)) + (1 - \phi'(t_1))\left[\frac{\partial^2 C^+}{\partial t_1^2}(t_1, \phi(t_1)) + \phi'(t_1)\frac{\partial^2 C^+}{\partial t_1 \partial t_2}(t_1, \phi(t_1))\right]$$

Differentiating the map $\frac{\partial C^+}{\partial t_1}$ at $(t_1, \phi(t_1))$ yields

$$\begin{aligned} \frac{\partial^2 C^+}{\partial t_1^2}(t_1, \phi(t_1)) &= -i\kappa(t_1)\frac{T(t_1) + T(t_2)}{T(t_1) - T(t_2)}\frac{\partial C^+}{\partial t_1}(t_1, \phi(t_1)) + \\ &+ i\frac{T(t_1)T(t_2)}{(T(t_1) - T(t_2))^2}\kappa'(t_1)(\gamma(t_1) - \gamma(t_2)) \end{aligned}$$

and

$$\frac{\partial^2 C^+}{\partial t_1 \partial t_2}(t_1, \phi(t_1)) = i\kappa(t_1)\frac{T(t_1) + T(t_2)}{T(t_1) - T(t_2)}\frac{\partial C^+}{\partial t_1}(t_1, \phi(t_1))$$

It is not difficult to check that $i\frac{T(t_1) + T(t_2)}{T(t_1) - T(t_2)}$ and $\frac{T(t_1)T(t_2)}{(T(t_1) - T(t_2))^2}$ are both real.

We recall that

$$\frac{\partial C^+}{\partial t_1}(t_1, \phi(t_1)) = i\kappa(t_1)\frac{T(t_1)T(t_2)}{(T(t_1) - T(t_2))^2}[\gamma(t_1) - \gamma(t_2) + \frac{1}{\kappa(t_1)}(N(t_1) - N(t_2))]$$

Therefore

$$\overline{r'}(t_1^0)r''(t_1^0) \text{ is real} \iff i\kappa'(t_1^0)(\gamma(t_1^0) - \gamma(t_2^0))\overline{\frac{\partial C^+}{\partial t_1}(t_1^0, t_2^0)} \text{ is real}$$

$$\iff \kappa'(t_1^0)(\gamma(t_1^0) - \gamma(t_2^0))\overline{(N(t_1^0) - N(t_2^0))} \text{ is real}$$

$$\iff \begin{cases} \kappa'(t_1^0) = 0, \text{ or} \\ (\gamma(t_1^0) - \gamma(t_2^0))\overline{(N(t_1^0) - N(t_2^0))} \text{ is real} \end{cases}$$

$$\iff \begin{cases} \kappa'(t_1^0) = 0, \text{ or} \\ \gamma(t_1^0) - \gamma(t_2^0) = \lambda(N(t_1^0) - N(t_2^0)), \lambda \in R \end{cases}$$

$$\iff \begin{cases} \kappa'(t_1^0) = 0, \text{ or} \\ C^+(t_1^0, t_2^0) \in SS \end{cases}$$

The case $C^+(t_1^0, t_2^0) \in SS$ is dealt with in more detail in the next section. We summarize the calculations in the following proposition.

5.3.5. Proposition : *The RSS^+ has an inflexion at $C^+(t_1^0, t_2^0)$ if and only if one of $\gamma(t_1^0)$ and $\gamma(t_2^0)$ is a vertex on the curve γ , or $C^+(t_1^0, t_2^0)$ is also the centre of a bitangent circle to the curve γ at $\gamma(t_1^0)$ and $\gamma(t_2^0)$.*

Suppose now that Σ^+ is no longer smooth at p_0 , i.e., $\kappa'(t_1^0) = \kappa'(t_2^0) = 0$. The function $K(t_1, t_2) = \kappa'(t_1) - \kappa'(t_2)$ is Morse when $\kappa''(t_1^0)\kappa''(t_2^0) \neq 0$. The set Σ^+ is the zero set of the function K . It is an isolated point when $\kappa''(t_1^0)\kappa''(t_2^0) < 0$ and a node when $\kappa''(t_1^0)\kappa''(t_2^0) > 0$. Using Corollary 3.4.4 and Example 3.4.5 we deduce the following.

5.3.6. Proposition : *For generic curves in the plane, the map C^+ is a “lips” map if $\kappa''(t_1^0)\kappa''(t_2^0) > 0$ and a “beaks” map if $\kappa''(t_1^0)\kappa''(t_2^0) < 0$. \square*

5.3.7. Corollary : For generic 1-parameter families of curves in the plane, the RSS^+ undergoes the “lips” transitions when $\kappa''(t_1^0)\kappa''(t_2^0) > 0$ and the “beaks” transition when $\kappa''(t_1^0)\kappa''(t_2^0) < 0$. \square

It is easier to see what is going on geometrically in the case of a lips or beaks transition on RSS^+ for a family of plane curves. Here, the set $\Sigma^+ = \{(t_1, t_2) : \kappa(t_1) = \kappa(t_2)\}$ is, at the moment of transition, itself singular, and it undergoes a Morse transition.

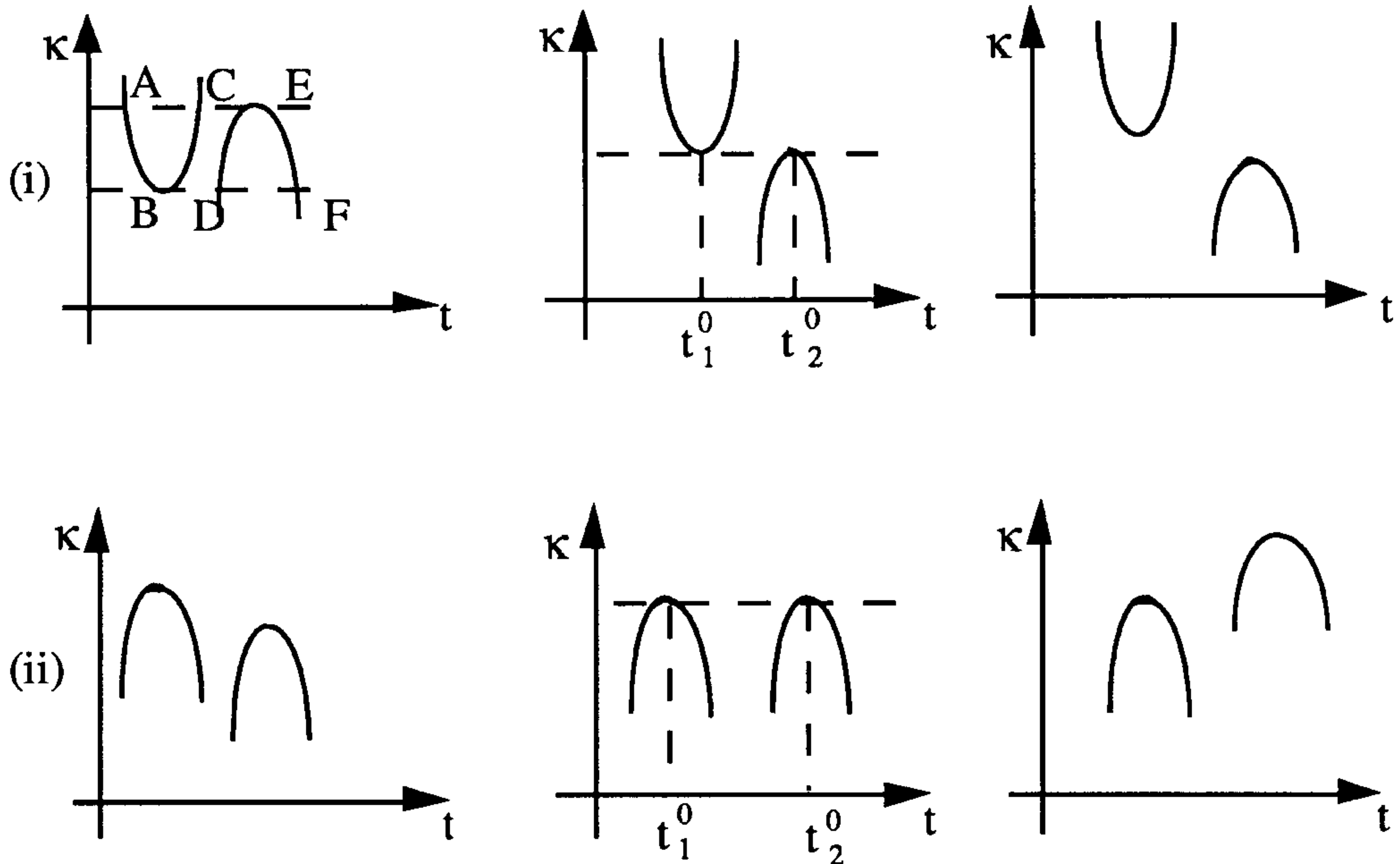

Figure 5.3.2. Changes in the κ -curve which give lips/beaks transitions on RSS^+

The conditions for lips and beaks are easy to visualize in terms of the curvature graph of γ . Consider for example the first part of (figure 5.3.2 (i)), which gives rise to an open lips. (Clearly, in the second transitional part of (figure 5.3.2 (i)), we have $\kappa''(t_1^0)\kappa''(t_2^0) < 0$.) Each pair (t_1, t_2) at the same level on the graph contributes a point $C^+(t_1, t_2)$ to RSS^+ . For instance the points on the arc AB of the graph are paired with those on the arc EF . Looking at $\kappa'(t)$ along AB (it goes from < 0 to 0) and along EF (it goes from 0 to < 0), it is clear that there will be some pair of points (t_1, t_2) where $\kappa'(t_1) = \kappa'(t_2)$, and this gives a cusp on RSS^+ (see the conditions in Corollary 5.3.3). Similarly BC and DE give a cusp somewhere; for sufficiently small perturbations from the transition state there will be just two cusps altogether. On the other hand pairs B, D ; B, F ; A, E ; C, E all give *inflexions* on RSS^+ ; the inflexion condition is $\kappa'(t_1)$ or $\kappa'(t_2) = 0$. Thus RSS^+ has four inflexions and two cusps. The lips in the lips transition has the unusual feature of having four inflexions. Notice that

this is similar to the situation for the dual of symmetry set at a “moth” in Chapter 4. (See figure 5.3.3 and compare with figure 4.2.9.)

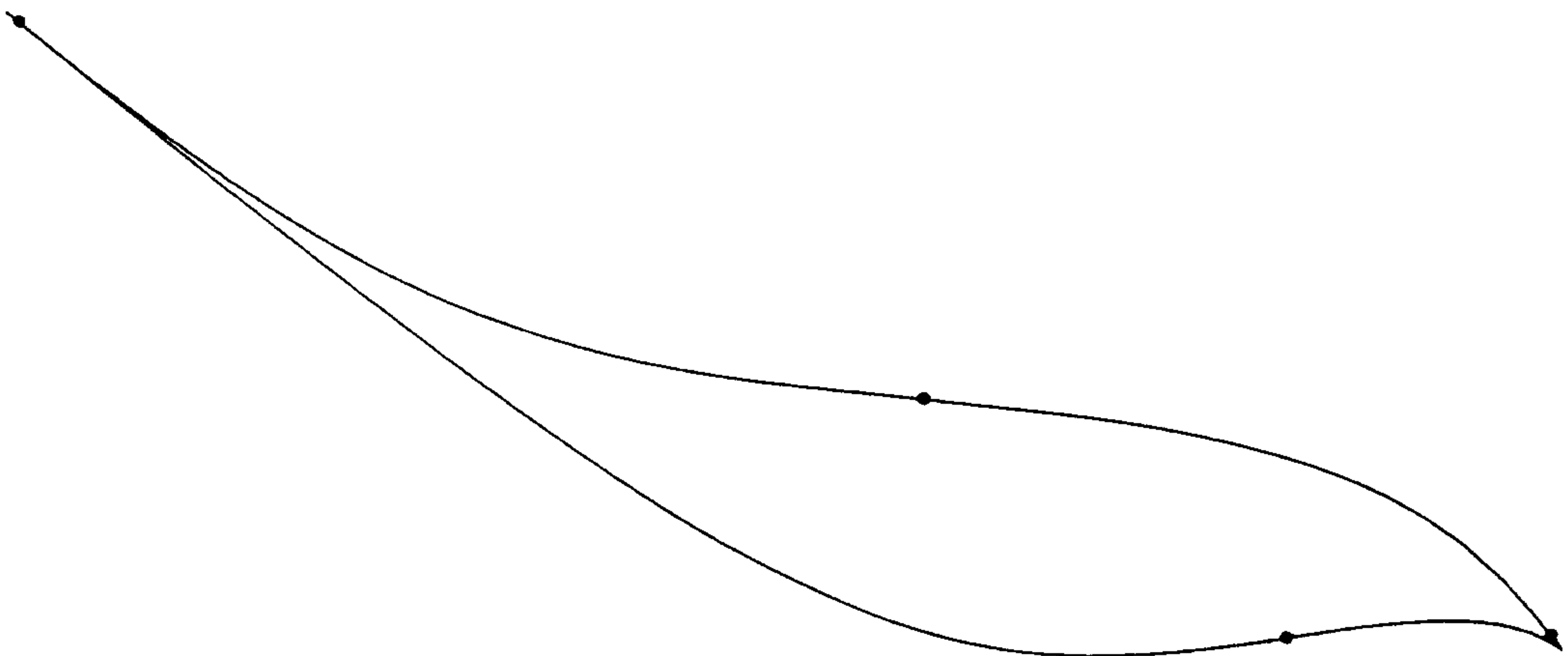

Figure 5.3.3. Richard Morris’s Computer picture of a lips on RSS^+

Similarly in (figure 5.3.3 (ii)), there is an inflexion on each branch of the beaks before and after the moment of transition (figure 5.3.4). This is as well an unusual feature on the beaks transitions. The same phenomenon occurs on the dual of the symmetry set at a “nib”.



Figure 5.3.4. Beaks transition on RSS^+
(Richard Morris’s picture)

II. The case where RSS^+ crosses the symmetry set

When $C^+(t_1^0, t_2^0)$ belongs to RSS^+ and also to SS (but not to the evolute, $t_1^0 \neq t_2^0$), the map C^+ tends to be more degenerate than in the case for swallowtail, lips or beaks in the previous section. (For instance, the map C^+ is of rank 0 at an A_2^2 point.) We denote by S the set of pairs of points (t_1, t_2) for which there exists a circle tangent to the curve at $\gamma(t_1)$ and $\gamma(t_2)$ and centred at $C^+(t_1, t_2)$. The critical set of the map C^+ is locally the union of Σ^+ and S .

We suppose for the moment that γ is taking its values in R^2 (not the complex

numbers). Then $S = \{(t_1, t_2) : (\gamma(t_1) - \gamma(t_2)) \cdot (T(t_1) - T(t_2)) = 0\}$ [G-B]. The set S is a smooth curve when the bitangent circle is not osculating at $\gamma(t_1^0)$ or at $\gamma(t_2^0)$. It consists of an isolated point or a node when the point (t_1^0, t_2^0) is an A_2^2 singularity of the distance squared function on γ (i.e., the circle is biosculating at $\gamma(t_1^0)$ and $\gamma(t_2^0)$). We deal with the two cases separately.

Case 1. The point (t_1^0, t_2^0) is not an A_2^2

The map C^+ is of rank 1 and the set S is a smooth curve. We can suppose that the bitangent circle is not osculating at $\gamma(t_2^0)$ so that S is parametrized by $(t_1, \psi(t_1))$ with $\psi(t_1^0) = t_2^0$ and $\psi'(t_1) = -\frac{1 - r\kappa(t_1)}{1 - r\kappa(\psi(t_1))}$, where r is the radius of the bitangent circle [G-B]. At (t_1^0, t_2^0) it is clear that $\psi'(t_1^0) = -1$ and the tangent to the curve S at that point is $(1, -1)$. For generic A_2^2 points the set Σ^+ is a smooth curve. Each time S intersects Σ^+ , the slope of its tangent at the point of intersection is -1 (figure 5.3.5, left).

The symmetry set, image of the curve S by the map C^+ , has an inflexion at $C^+(t_1^0, t_2^0)$ when $\kappa(t_1^0) = \kappa(t_2^0)$ [G-B]. The RSS^+ has also an inflexion at $C^+(t_1^0, t_2^0)$ (see Proposition 5.3.5). Thus, the RSS^+ and the SS have inflexions at their point of intersection and the two curves are tangential (figure 5.3.5, right).



Figure 5.3.5

The condition for Σ^+ and S to be tangential at (t_1^0, t_2^0) is that the slope of the tangent to Σ^+ at (t_1^0, t_2^0) is -1 . This happens when $\phi'(t_1^0) = \frac{\kappa'(t_1^0)}{\kappa'(t_2^0)} = -1$, equivalently $\kappa'(t_1^0) = -\kappa'(t_2^0)$. This condition is not satisfied for generic curves. Thus, generically the two curves Σ^+ and S intersect transversally.

When $\kappa'(t_1^0) = -\kappa'(t_2^0)$ one can show by computing the second derivative of the function ψ that the curve S has an inflexion at (t_1^0, t_2^0) . The condition $\kappa'(t_1^0) = -\kappa'(t_2^0)$ is expected to hold generically at isolated points on 1-parameter families of curves γ . The union of the two curves Σ^+ and S appears to have the transition drawn in (figure 5.3.6 (i)), and their images undergo the transition in (figure 5.3.6 (ii)). In fact one can prove that the RSS^+ and the SS have higher inflexions at $C^+(t_1^0, t_2^0)$ when $\kappa'(t_1^0) = -\kappa'(t_2^0)$.

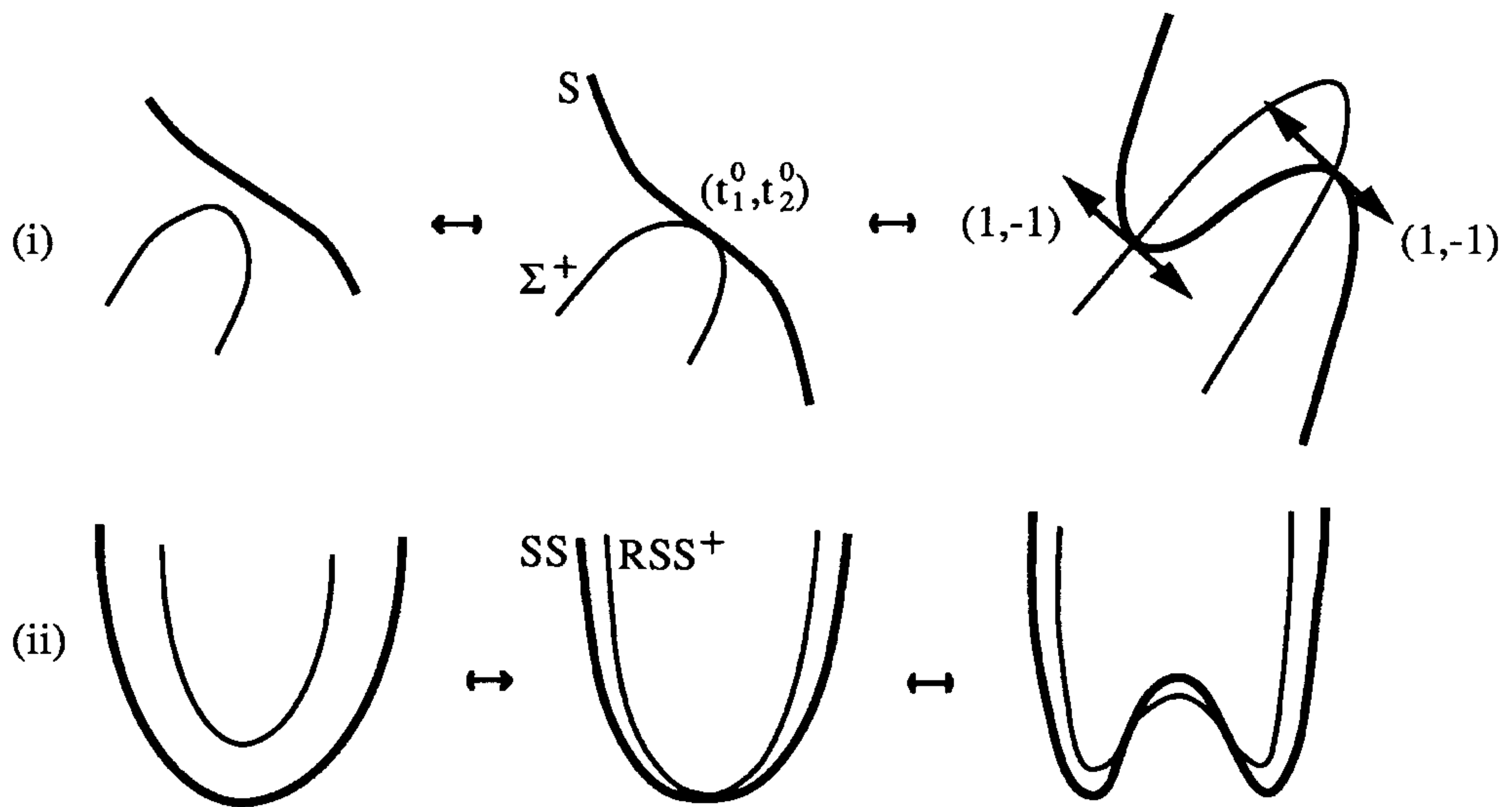

Figure 5.3.6

The condition $\kappa'(t_1^0) = \kappa'(t_2^0)$ can occur generically at isolated points on 1-parameter families of curves γ . The rotational symmetry set is singular as $r'(t_1^0) = 0$. In fact in this case it is not hard to show that RSS^+ has a rhamphoid cusp (for, the conditions on RSS^+ to have a rhamphoid cusp at $C^+(t_1^0, t_2^0)$ are $C^+(t_1^0, t_2^0) \in SS$ and $\kappa'(t_1^0) = \kappa'(t_2^0)$). Notice that the tangent vector at (t_1^0, t_2^0) to the curve Σ^+ is $(1,1)$. The curves Σ^+ and S meet transversally and their tangent vectors are perpendicular at the point of intersection. In (figure 5.3.7) we draw what should be the generic transition on $RSS^+ \cup SS$ at a rhamphoid cusp on the RSS^+ .

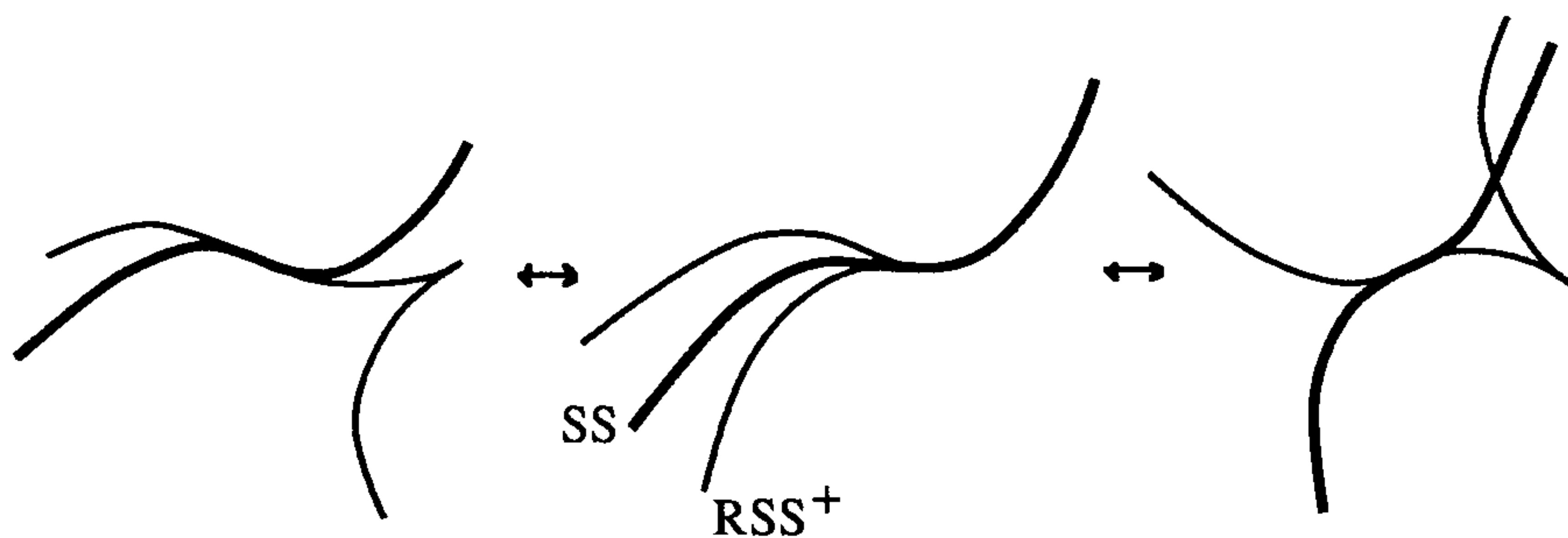

Figure 5.3.7

Case 2. The point (t_1^0, t_2^0) is an A_2^2

An A_2^2 occurs on the SS when the bitangent circle to the curve γ is osculating at $\gamma(t_1^0)$ and $\gamma(t_2^0)$. The centres of curvatures $e(t_1^0)$ and $e(t_2^0)$ coincide. We saw in proof of Proposition 5.3.2 that in these conditions the vectors $\frac{\partial C^+}{\partial t_1}(t_1^0, t_2^0)$ and $\frac{\partial C^+}{\partial t_2}(t_1^0, t_2^0)$ are both zero. The map C^+ is of rank 0 at (t_1^0, t_2^0) . This makes it harder to identify rigorously how RSS^+ behaves in a 1-parameter family. However, we treat this case

by an informal genericity argument and putting together information found previously by studying the symmetry set and the rotational symmetry set.

For example, we know that at an A_2^2 point the SS undergoes generically “moth” transitions when $\kappa'(t_1^0)\kappa'(t_2^0) > 0$ and “nib” transitions when $\kappa'(t_1^0)\kappa'(t_2^0) < 0$ [B-G3]. Our investigation on the duals of symmetry sets in Chapter 4 highlighted the existence of two inflexions on the moth in the moth transition, and one inflexion on each component of the nib on just one side on the nib transition. We know from the previous section that these inflexions points are also inflexion points on RSS^+ , and that the two sets RSS^+ and SS are tangential.

The set $\{(t_1, t_2): \kappa(t_1) = \kappa(t_2)\}$ is smooth at a generic A_2^2 on the curve γ . The rotational symmetry set RSS^+ is parametrized by $r(t_1) = C^+(t_1, \phi(t_1))$ as in the previous section. At (t_1^0, t_2^0) the vector $r'(t_1^0) = 0$ but $r''(t_1^0)$ and $r'''(t_1^0)$ are linearly independent. The rotational symmetry set has an ordinary cusp at $C^+(t_1^0, t_2^0)$.

Combining the information on SS and RSS^+ , we draw in (figure 5.3.8) what appears to be the generic transition on $RSS^+ \cup SS$ at an A_2^2 point on the curve γ .

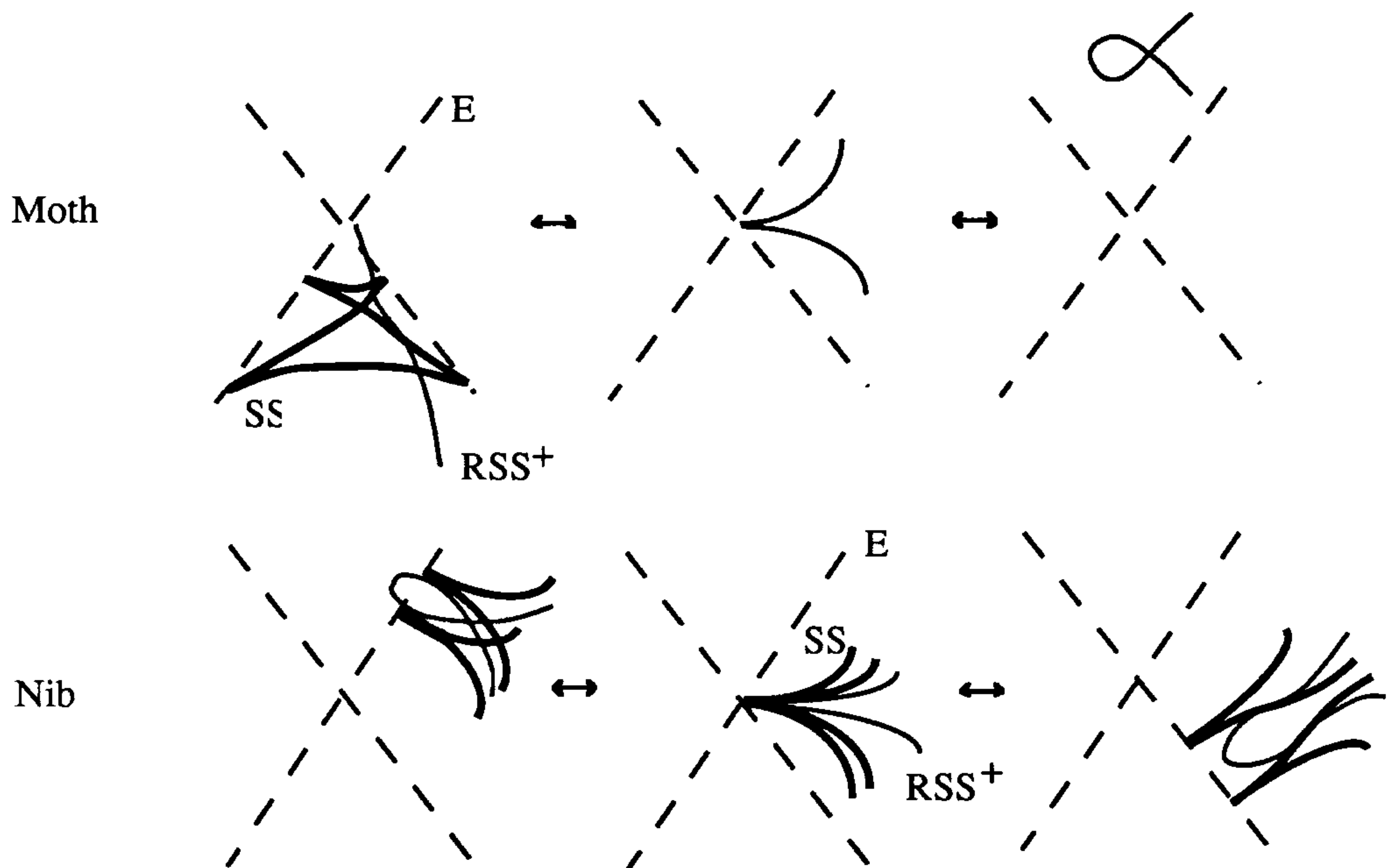

Figure 5.3.8

III. The case where RSS^+ crosses the symmetry set and the evolute

If $C^+(t_1, t_2) \in RSS^+$ for sequences $t_1 \rightarrow t_0$, $t_2 \rightarrow t_0$ then $\kappa'(t_0) = 0$. The curve γ has an ordinary vertex at $\gamma(t_0)$ provided that $\kappa''(t_0) \neq 0$. The map C^+ is symmetric with respect to the diagonal $\Delta = \{(t, t): t \in R\}$ and has rank zero at (t_0, t_0) . The symmetry set has an endpoint at the centre of curvature $e(t_0)$ and the evolute has

an ordinary cusp. The set $\{(t_1, t_2): \kappa(t_1) = \kappa(t_2)\}$ is a smooth curve symmetric with respect to the diagonal Δ . Its image by C^+ , the RSS^+ , is a curve with an endpoint. The endpoint is the centre of curvature $e(t_0)$ (figure 5.3.9).

Ordinary vertices are generic features on smooth curves. The endpoints on SS and RSS^+ are therefore stable. (This contrasts with the fact that the map C^+ is degenerate at a vertex.)

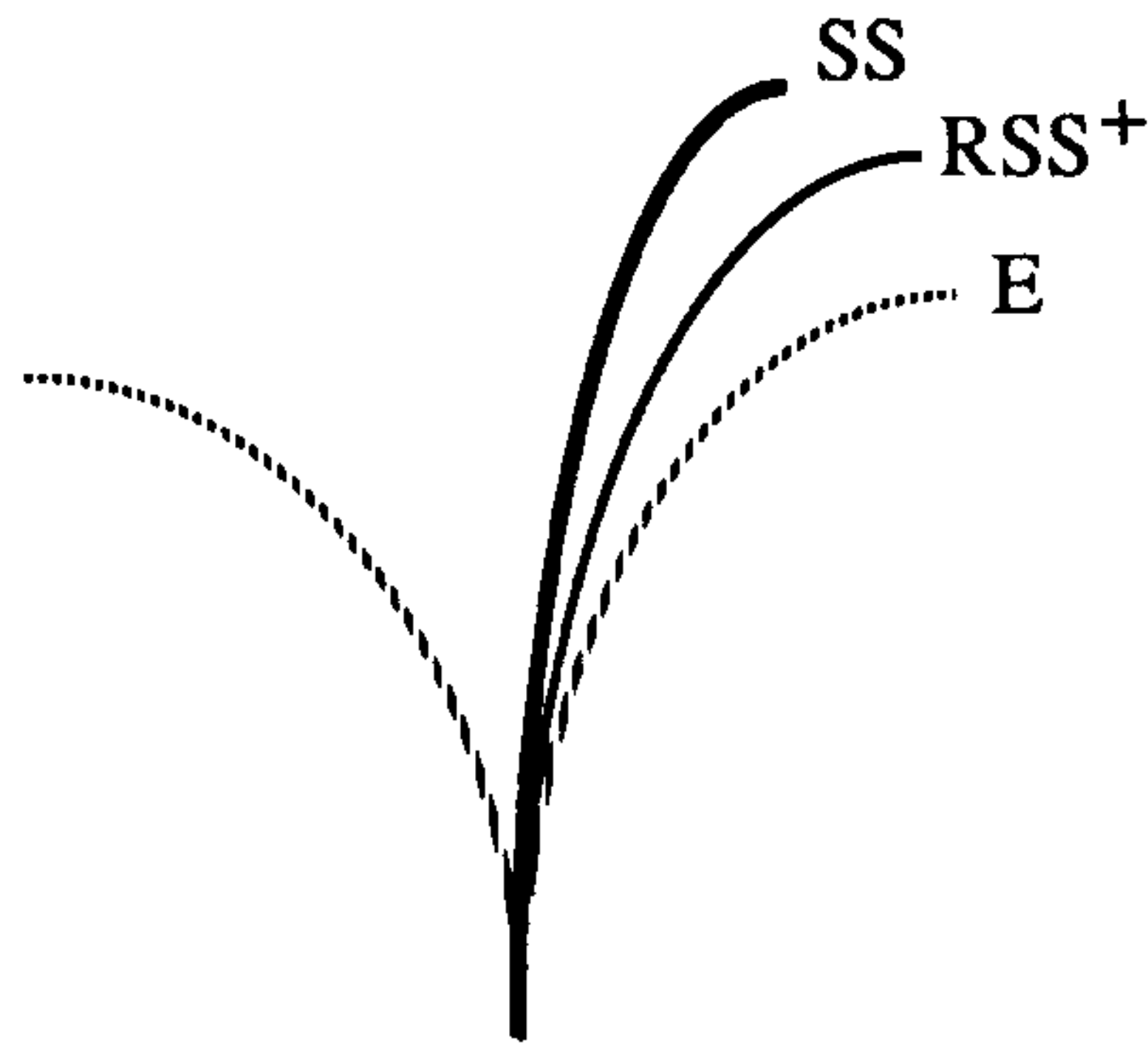

Figure 5.3.9

Higher vertices occur generically at isolated points in 1-parameter families of curves γ . The condition is $\kappa'(t_0) = \kappa''(t_0) = 0$ and $\kappa'''(t_0) \neq 0$. We suppose that $t_0 = 0$. The Taylor development of the curvature function in a neighbourhood of the origin is given by $\kappa(t) = \kappa(0) + \kappa'''(0)t^3 + O(t^4)$. The germ of the function κ is equivalent, by smooth changes of coordinates in the source and target, to t^3 . Any perturbation of κ is contained in the family $t^3 + ut$. For a generic 1-parameter family of curves γ_s , the corresponding family of curvature functions $\kappa(t, s) = \kappa_s(t)$ is a versal unfolding of the germ $\kappa_0 = \kappa$, so that $\kappa(\alpha(t, s), \beta(s)) = t^3 + st$, with $\alpha(-, 0), \beta$ germs of diffeomorphisms. The set $\{(t_1, t_2, s): \kappa(t_1, s) = \kappa(t_2, s)\}$ is diffeomorphic to the set $\{(t_1, t_2, s): t_1^3 + st_1 = t_2^3 + st_2\}$. It is enough to study the generic sections on the set $\{(t_1, t_2, s): t_1^3 + st_1 = t_2^3 + st_2\}$ in order to find the generic transitions on the sets Σ_s^+ and hence those on RSS^+ . Calculations show that the generic sections on $\{(t_1, t_2, s): t_1^3 + st_1 = t_2^3 + st_2\}$, and therefore on Σ_s^+ , are the ones shown in (figure 5.3.10).

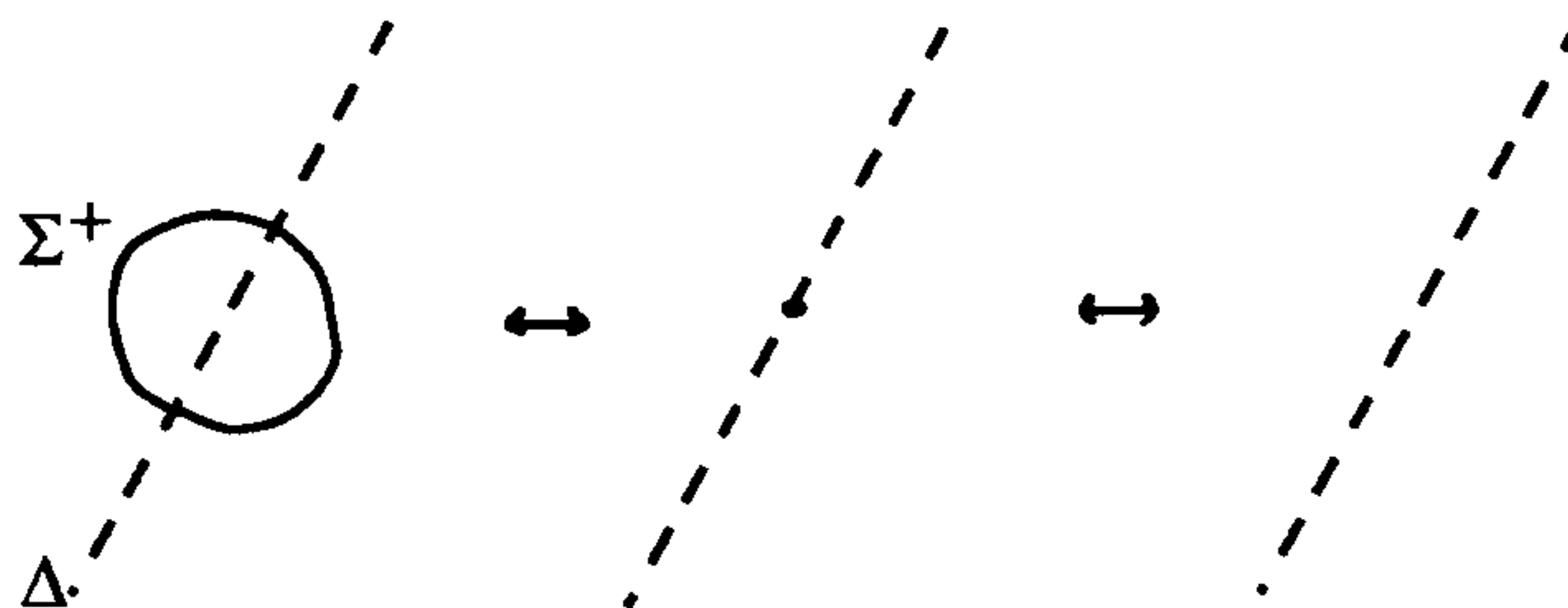

Figure 5.3.10

The closed curve Σ_s^+ is symmetric with respect to the diagonal Δ as the map C^+ is symmetric with respect to Δ . Two symmetric points on Σ_s^+ are mapped to the same point by C^+ . The rotational symmetry set is then a curve with two endpoints. The endpoints are the images of the intersection points of Σ_s^+ with Δ , that is the cusp points on the evolute. There is a point on Σ_s^+ where the tangent is parallel to the diagonal. The curvature satisfies the condition $\kappa'(t_1) = \kappa'(t_2)$ at such points and the image by C^+ is a cusp on RSS^+ . There is also a point on Σ_s^+ where the tangent is parallel to the t_1 -axis (*i.e.*, $\kappa'(t_2) = 0$) and another point where the tangent is parallel to the t_2 -axis (*i.e.*, $\kappa'(t_1) = 0$). The corresponding points on RSS^+ are inflexion points. We come to the conclusion that the RSS^+ has the following transition at a higher vertex on the curve γ (figure 5.3.11).

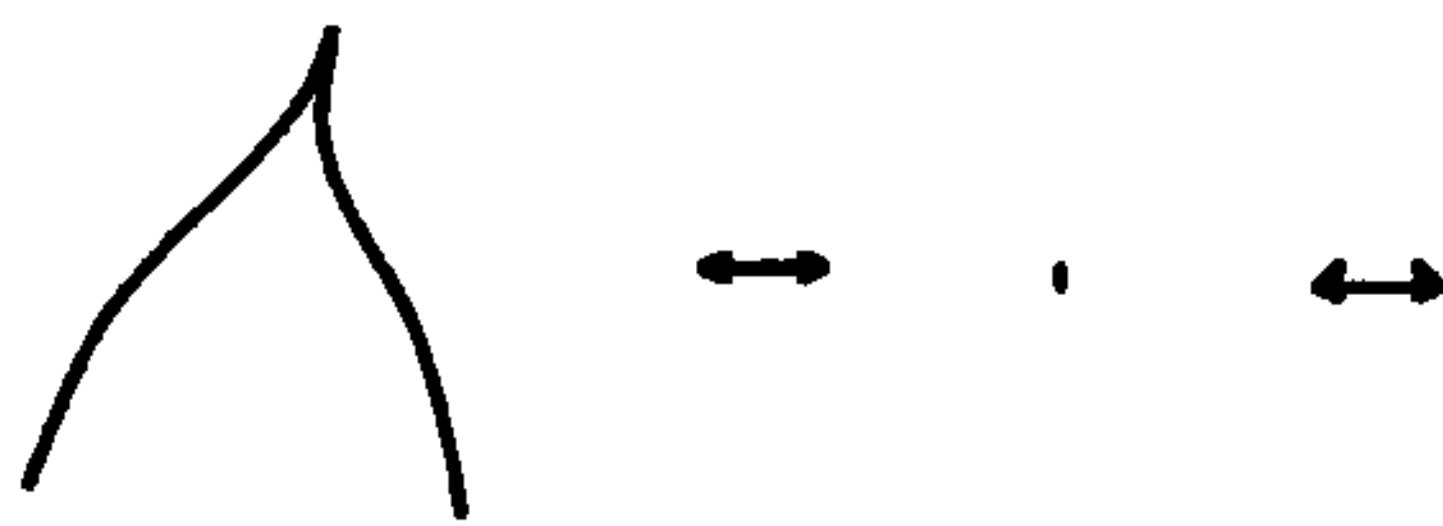

Figure 5.3.11

Note that the inflexions on RSS^+ do not derive from the intersection of RSS^+ and SS . Indeed, the dual of the symmetry set at an A_4 -point (higher vertex) shows that there are no inflexions on SS at the A_4 transition. We gather information on RSS^+ , SS and E and draw the generic transition on the critical locus of the map C^+ at a higher vertex in (figure 5.3.12).

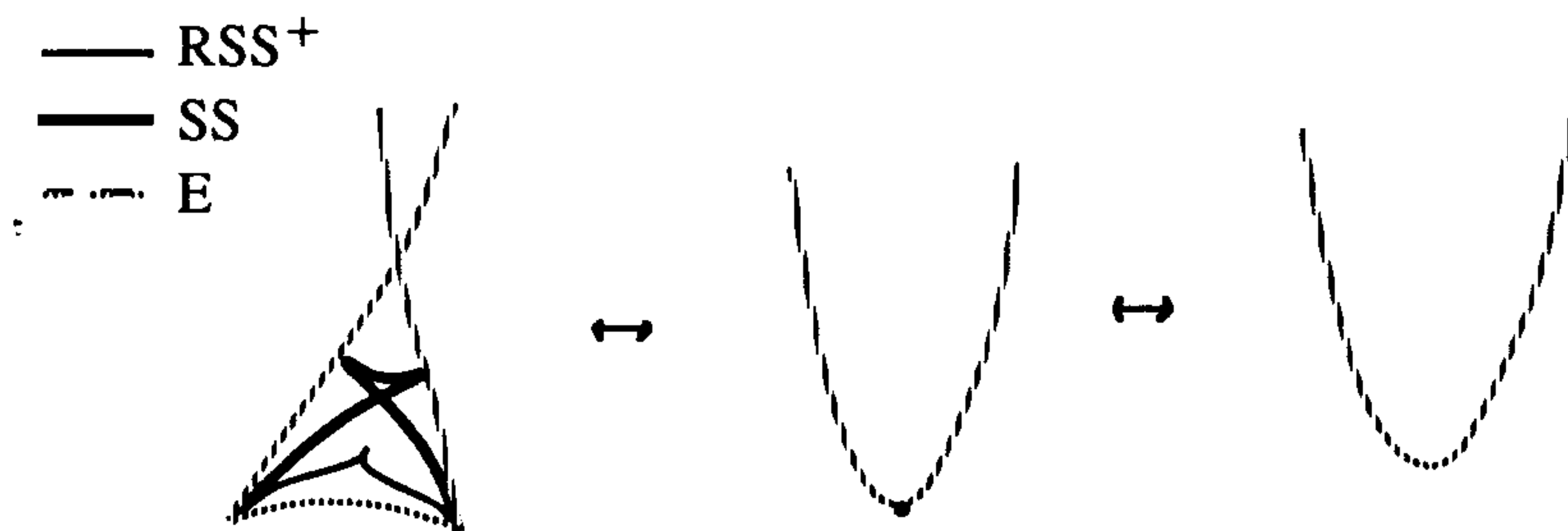

Figure 5.3.12

§4. The RSS^- and the connexion with symmetric maps

RSS^- arises as part of the set of critical values of the map C^- in much the same way that RSS^+ arises from C^+ . If we consider $t_1 \neq t_2$ where $\kappa(t_1) = -\kappa(t_2)$ the point $C^-(t_1, t_2)$ is the same as $C^+(t_1, t_2)$ obtained by reversing the orientation of γ near t_2 . Of course this cannot be done globally, but it means the *local* structure of the RSS^- is the same as that of RSS^+ except close to points (t, t) .

So consider say $t = t_0$ on γ and assume that $C^-(t_0, t_0)$ is on RSS^- , which requires $\kappa(t_0) = 0$. If t_0 is an ordinary inflexion on γ ($\kappa'(t_0) \neq 0$), then the set $\Sigma^- = \{(t_1, t_2): \kappa(t_1) = -\kappa(t_2)\}$ is a smooth curve close to $p_0 = (t_0, t_0)$, while if t_0 is a higher inflexion ($\kappa'(t_0) = 0, \kappa''(t_0) \neq 0$) then Σ^- has an isolated point at p_0 . The image $RSS^- = C^-(S^-)$ is a smooth curve with an endpoint at $\gamma(t_0)$ in the first case and is merely $\{\gamma(t_0)\}$ in the second (figure 5.4.1).

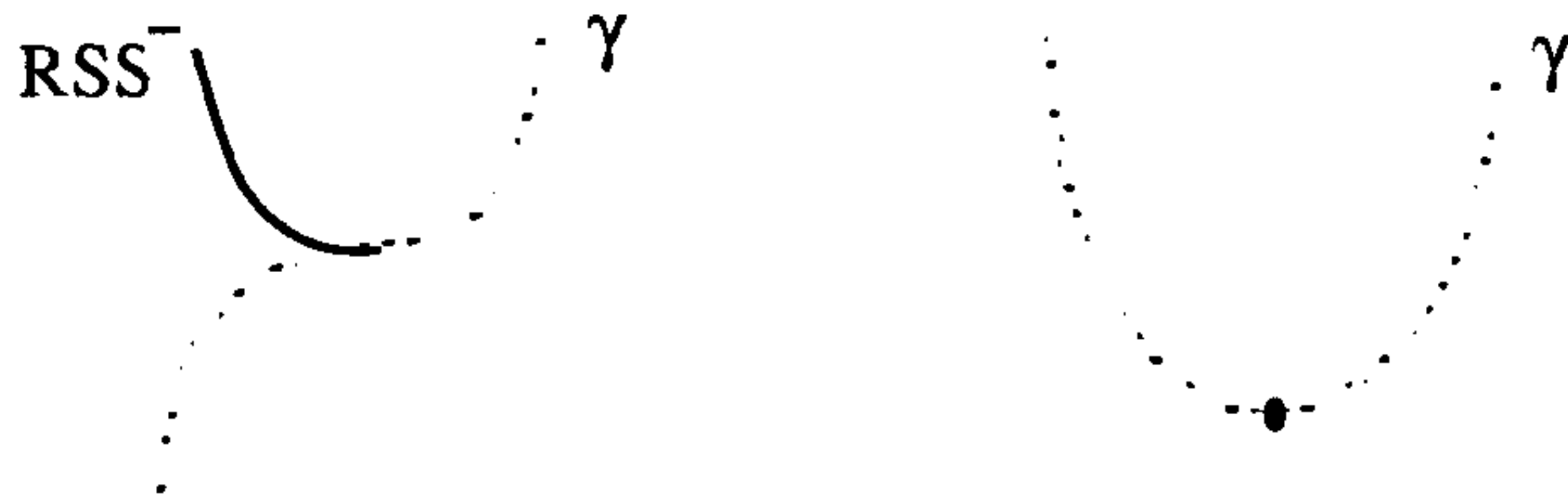

Figure 5.4.1. RSS^- near an inflexion and higher inflexion on γ

Note that the map $C^-: R \times R \rightarrow \mathbf{C} = R^2$ is *symmetric* with respect to interchange of variables in the source: $C^-(t_1, t_2) = C^-(t_2, t_1)$. Of course, the same goes for C^+ , but when we examine C^+ close to a point (t_0, t_0) where $C^+(t_0, t_0) \in RSS^+$ we find C^+ is very degenerate (see §3). On the other hand with C^- , the critical set near a point $p_0 = (t_0, t_0)$ with $\kappa(t_0) = 0$ consists precisely of Σ^- and the diagonal $\Delta = \{(t, t)\}$. The image $C^-(\Sigma^-)$ is RSS^- and $C^-(\Delta)$ is the curve $\gamma(I)$ itself. This means that we can study the pair $(RSS^-, \gamma(I))$ using the classification of symmetric maps found in Chapter 4 Table 4.3.5.

As in §3, we seek a method of recognition of symmetric map germs of rank greater than 1 and codimension less than 2. It is not difficult to see that the criteria in Chapter 3 can be adapted to the situation of symmetric maps. Let $F(x, y) = (x, f(x, y^2))$ be a symmetric map with respect to the x -axis. Then the critical set of F at $(0, 0)$ is the set $\{(x, y): y \frac{\partial f}{\partial y}(x, y^2) = 0\}$. The x -axis, axis of symmetry, is part of the critical set. Let $S = \{(x, y): \frac{\partial f}{\partial y}(x, y^2) = 0\}$. When S is smooth, one can show following the same calculations as in Chapter 3, that the order of contact of S with the kernel line of $DF(0, 0)$ determines the germs $(x, y^2), (x, xy^2 + y^4), (x, xy^2 + y^6)$. When S is singular but $\frac{\partial f}{\partial y}(x, y^2)$ is a germ of a Morse function, then F is equivalent in the equivariant sense to $(x, x^2y^2 + \epsilon y^4)$. In the following *equivalent* means equivalent in the equivariant sense.

5.4.1. Proposition : *Let F be a germ of a symmetric map with respect to the x -axis. Then*

- (i). *F is equivalent to (x, y^2) if and only if $S = \emptyset$.*

(ii). F is equivalent to $(x, xy^2 + y^4)$ if and only if S is smooth and has 2-point contact with $\ker DF(0,0)$.

(iii). F is equivalent to $(x, xy^2 + y^6)$ if and only if S is smooth and has 3-point contact with $\ker DF(0,0)$.

(iv). F is equivalent to $(x, x^2y^2 + \epsilon y^4)$ if and only if S is the zero set of a Morse function. \square

For the map C^- , the set S is Σ^- , and the kernel of $DC^-(t_0, t_0)$ is the line $t_2 = -t_1$. We have the following.

5.4.2. Corollary : *The map C^- is equivalent to:*

(i). (x, y^2) if and only if $\kappa(t_0) \neq 0$.

(ii). $(x, xy^2 + y^4)$ if and only if $\kappa'(t_0) \neq 0$, $\kappa(t_0) = 0$, $\kappa''(t_0) \neq 0$ (ordinary inflexion on the curve). The pair $(RSS^-, \gamma(I))$ has locally the stable structure of (figure 5.4.2 (i))

(iii). $(x, xy^2 + y^6)$ if and only if $\kappa'(t_0) \neq 0$, $\kappa(t_0) = \kappa''(t_0) = 0$, $\kappa'''(t_0) \neq 0$. The pair $(RSS^-, \gamma(I))$ undergoes a transition as in (figure 5.4.2 (ii)) on generic 1-parameter families of curves γ_s with $\gamma_0 = \gamma$.

(iv). $(x, x^2y^2 + y^4)$ if and only if $\kappa(t_0) = \kappa'(t_0) = 0$, $\kappa''(t_0) \neq 0$. The pair $(RSS^-, \gamma(I))$ undergoes a transition as in (figure 5.4.2 (ii)) on generic 1-parameter families of curves γ_s with $\gamma_0 = \gamma$. \square

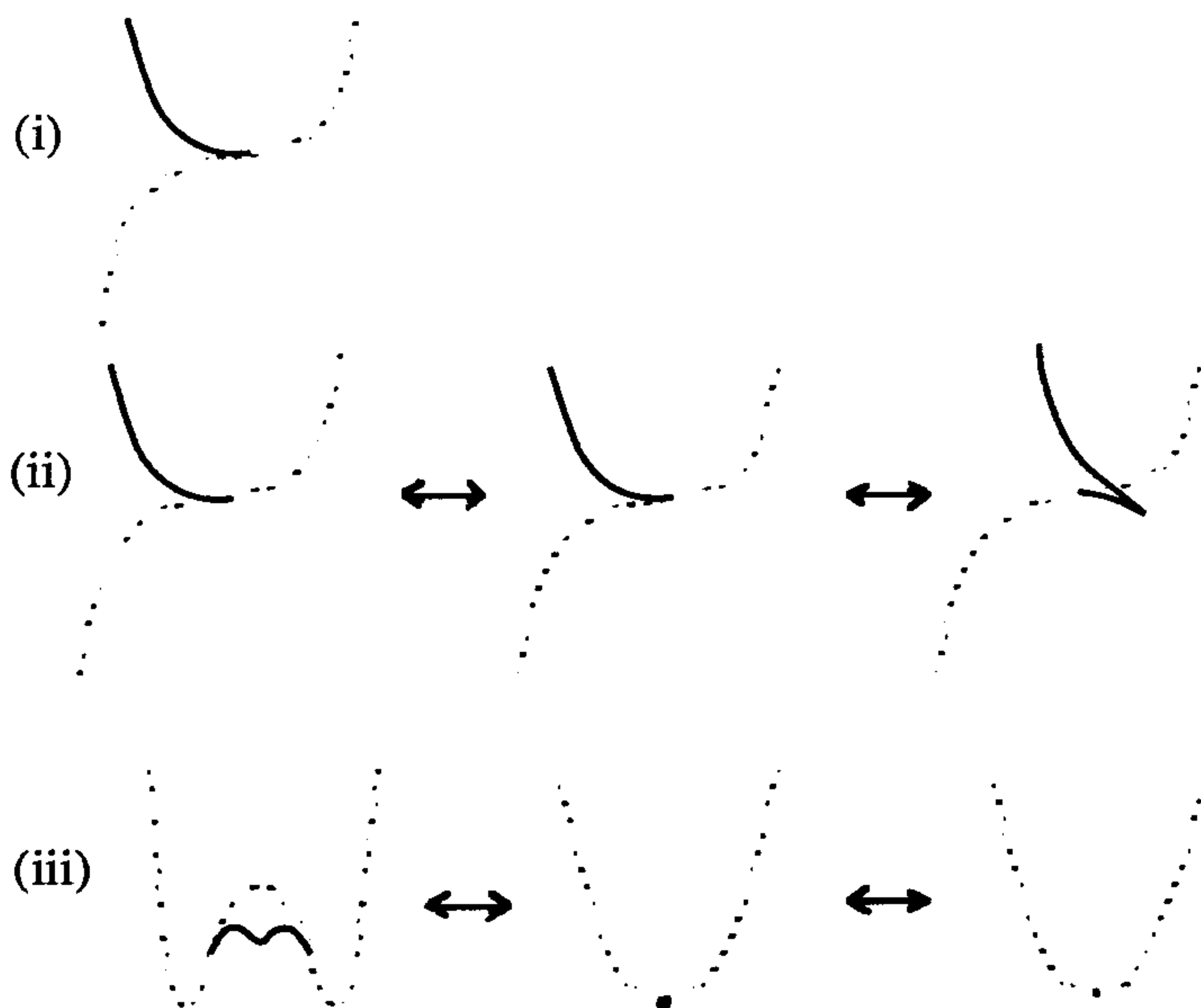

Figure 5.4.2. Transitions on 1-parameter families of RSS^-

Chapter 6

Midpoint locus of smooth surfaces

§1. Introduction

In Chapter 4 we investigated the local reflexional symmetry of smooth embedded curves in the plane and pointed out the duality with the Symmetry Sets. We recall that the symmetry set of a plane curve is defined in [G-B] to be the locus of centres of bitangent circles to the curve. This definition originated from the “*sym-ax*” of H.Blum [Bl]. He suggested, as a tool of studying the shape of a planar object, to fit disks inside it and consider the locus of their centers which he called “*sym-ax*”. Different approaches to studying the symmetry set have been made [B-G-Gi], [B-G3], [G], [G-B], but the most fruitful is the one which describes it as part of a full bifurcation set of the family of distance squared functions [B-G3]. It is then possible to apply singularity theory to describe the deformations in 1-parameter families of symmetry sets.

Although the symmetry set captures the infinitesimal symmetry of the curve it has been criticized for its sensitivity to noise and unintuitive relation with the shape of a curve [Bra]. M.Brady proposed instead of the center of the circles to take the mid-point of the chord of contact [Bra]. In [G-B] the locus of all these mid-points is called the *midpoint locus* of the curve and a direct argument for studying the structure of the midpoint locus of smooth embedded curves is given. If γ is a unit speed curve and T its tangent vector, the set of pairs of points of contact of bitangent circles to the curve γ is $S = \{(t_1, t_2) : (\gamma(t_1) - \gamma(t_2)) \cdot (T(t_1) \pm T(t_2)) = 0\}$. The set S is given as the zero set of the function $g(t_1, t_2) = (\gamma(t_1) - \gamma(t_2)) \cdot (T(t_1) \pm T(t_2))$. By the Implicit Function Theorem S is locally a smooth curve parametrized by t_1 provided the bitangent circle is not osculating at $\gamma(t_2)$. The midpoint locus of γ is the image of S by the map m defined by $m(t_1, t_2) = \frac{1}{2}(\gamma(t_1) + \gamma(t_2))$. The map m is in general a diffeomorphism, so the midpoint locus inherits the structure of S . Unfortunately this method encounters some problems: it is not possible to study rigorously the transitions which occur in families of midpoint loci and it is hard to extend it to the surface case. But unlike the symmetry set, there is no apparent way of expressing the midpoint locus as a discriminant or a bifurcation set and applying standard techniques of singularity theory.

In this chapter we overcome this problem by using information on the distance squared function. (We deal only with the surface case but the same method applies for the curve case.) We obtain the set of pairs of points of contact of bitangent spheres to the surface from the distance squared function as follows. Let M be locally a

surface parametrized by $s : R^2 \rightarrow R^3$ and $d : R^2 \times R^3 \rightarrow R$, the distance squared function on M . The set S_d of points $(x_1, x_2, a) \in R^2 \times R^2 \times R^3$ where the restriction of d to $R^2 \times \{a\}$ has two singularities x_1 and x_2 at the same level is invariant under isomorphisms of unfoldings in the sense that, if d' is an n -unfolding of an equivalent germ to d_{a_0} , the restriction of d to $R^2 \times \{a_0\}$, there is a diffeomorphism $H : R^2 \times R^2 \times R^3 \rightarrow R^2 \times R^2 \times R^3$ taking S_d to $S_{d'}$ (Lemma 6.2.1). It is then possible to compute S_d for normal forms of the singularities of d_{a_0} following the approach used in [W2] and [B-G-Gi]. The set of pairs of points of contact of bitangent spheres is the projection of S_d to $R^2 \times R^2$. (Note that the projection of S_d on R^3 is the Symmetry Set of M .) It is ideal if the following diagram commutes, when H is restricted to S_d , for some choice of bottom map.

$$\begin{array}{ccc} R^2 \times R^2 \times R^3 & \xrightarrow{H} & R^2 \times R^2 \times R^3 \\ \downarrow pr & & \downarrow pr \\ R^2 \times R^2 & \longrightarrow & R^2 \times R^2 \end{array}$$

We do not know if this is true. But if we take d' to be the unfolding of the normal form of the singularity of d_{a_0} we can use a geometrical argument to deduce the structure of $pr(S_d) = pr \circ H(S_{d'})$ from that of $S_{d'}$.

In the surface case we are mainly interested in the cases when the distance squared function is an unfolding of an A_3, A_4, D_4^\pm and A_2^2 singularities. For each of these singularities we compute S_f for the unfolding f of their normal forms.

§2. Computation of S_f

Let M be a generic smooth surface locally parametrized by $s : R^2 \rightarrow M$ in a neighbourhood of the origin. The distance squared function is defined as follows.

$$\begin{aligned} d : R^2 \times R^3 &\longrightarrow R \\ (x, a) &\longmapsto \|s(x) - a\|^2 \end{aligned}$$

The scalar $d(x, a)$ is the square of the distance between the point a in R^3 and $s(x)$ on the surface M . When $d_a = d|_{R^2 \times \{a\}}$ is singular at the origin, the map d is an unfolding of this singularity. For generic surfaces, d_{a_0} has singularities of type A_3, A_4, D_4^\pm at the origin. The distance squared function is a versal unfolding of these singularities [W1]. In [B-G3] the authors considered the full bifurcation set of d :

$$\begin{aligned} B(d) = \{a \in R^3 : d_a \text{ has a degenerate singularity at some } x \in R^2 \\ \text{or two singularities } x_1, x_2 \text{ where } d(x_1, a) = d(x_2, a)\} \end{aligned}$$

For the midpoint locus we shall look at the singularities (x_1, x_2) of d at the same

level. We first define the set

$$S_d := \{(x_1, x_2, a) : d_a \text{ is singular at } x_1 \text{ and } x_2 \text{ and } d_a(x_1, a) = d_a(x_2, a) \\ \text{or } x_1 = x_2 \text{ and } d_a \text{ has a degenerate singularity at } x_1\}$$

Geometrically, d_a is singular at x_1 when the sphere of center a is tangent to the surface M at $s(x_1)$. The projection of S_d on $R^2 \times R^2$, $pr(S_d)$, can be seen as the set of points of contact of bitangent spheres with the surface M . The set $pr(S_d)$ is symmetric with respect to the diagonal $D = \{(x, x), x \in R^2\}$.

In the following we show that S_d is invariant under isomorphisms of unfoldings. Let f and g be two r -versal unfolding of the same singularity. Then f and g are isomorphic as unfoldings [Br-L], ie ,

$$f(x, a) = \alpha.g(\phi(x, a), \psi(a)) + \beta(a) \quad (*)$$

with $\phi(-, a)$ and ψ being diffeomorphisms and $\alpha'(0) \neq 0$.

6.2.1. Lemma : *Let f and g as above. Then S_f and S_g are diffeomorphic.*

Proof : The proof follows trivially using the equation (*). If we denote by $\nabla F(x)$ the gradient of the map F at x , then

$$\begin{aligned} (x_1, x_2, a) \in S_f &\iff \begin{cases} f(x_1, a) = f(x_2, a), \\ \nabla f(x_1, a) = \nabla f(x_2, a) = 0 \end{cases} \\ &\iff \begin{cases} g(\phi(x_1, a), \psi(a)) = g(\phi(x_2, a), \psi(a)), \\ \nabla\{g(\phi(x_1, a), \psi(a))\} = \nabla\{g(\phi(x_2, a), \psi(a))\} = 0 \end{cases} \\ &\iff \begin{cases} g(\phi(x_1, a), \psi(a)) = g(\phi(x_2, a), \psi(a)), \\ \nabla g(\phi(x_1, a), \psi(a)).D\phi = (\nabla g)(\phi(x_1, a), \psi(a)).D\phi = 0 \end{cases} \end{aligned}$$

Since $\phi(-, a)$ is locally a diffeomorphism then

$$\begin{aligned} (x_1, x_2, a) \in S_f &\iff \begin{cases} g(\phi(x_1, a), \psi(a)) = g(\phi(x_2, a), \psi(a)) \\ \nabla g(\phi(x_1, a), \psi(a)) = \nabla g(\phi(x_2, a), \psi(a)) = 0 \end{cases} \\ &\iff (\phi(x_1, a), \phi(x_2, a), \psi(a)) \in S_g \end{aligned}$$

Let $H : R^2 \times R^2 \times R^3 \longrightarrow R^2 \times R^2 \times R^3$ with $H(x_1, x_2, a) = ((\phi(x_1, a), \phi(x_2, a), \psi(a)))$. From the properties of the maps ϕ and ψ , H is a germ of a diffeomorphism, and from the above calculations $H(S_f) = S_g$. \square

In the following section we shall compute S_f for the unfoldings of the normal forms of the singularities A_3, A_4, D_4^\pm and A_2^2 . The calculations follow the same

patterns those in [W2] and [B-G-Gi] with the difference that here we are interested in the critical points of f at the same level rather than the discriminant of f or its full bifurcation set. (This amounts to working in the source.) We shall carry out the calculations for each case.

6.2.2. The D_4^+ case

The normal form of a D_4^+ singularity is given by $x^3 + y^3$ [A1], and a versal unfolding is $f = x^3 + y^3 + axy + bx + cy$. The germ f has two real singularities at the same level if there exists a scalar d for which $f - d$ has two real singularities, that is the plane cubic $f = d$ has a real line component meeting the residual conic at two real points. The conditions for $f = d$ to have a line component $\ell : x + \alpha y + \beta = 0$ are: $b = c$, $\alpha = 1$, $\beta = -\frac{a}{3}$. Then $f = (x + y - \frac{a}{3})(x^2 - xy + y^2 + \frac{a}{3}x + \frac{a}{3}y - \frac{a^2}{9} + b)$. If we write $f - d = \ell \cdot Q$ where Q is the irreducible conic $x^2 - xy + y^2 + \frac{a}{3}x + \frac{a}{3}y - \frac{a^2}{9} + b = 0$, then $f - d$ is singular if and only if $\ell = Q = 0$.

$$\ell = 0 \iff x + y - \frac{a}{3} = 0 \iff x = -y + \frac{a}{3} \quad \text{and} \quad (1)$$

$$Q = 0 \iff x^2 - xy + y^2 + \frac{a}{3}x + \frac{a}{3}y - \frac{a^2}{9} + b = 0 \quad (2)$$

Replacing in (2) x by its expression in (1) yields: $3y^2 - ay + \frac{a^2}{9} + b = 0$ (*). The discriminant of this equation is $\Delta = -(\frac{a^2}{3} + 12b)$. The line ℓ and the cone Q have two points of intersection when $\Delta > 0$. These points are the A_2 singularities of f . When $\Delta = 0$ the line ℓ is tangent to the cone Q at an A_3 singularity of f . We can find these A_2 and A_3 singularities by solving (*) and (1) and we get:

$$S_f = \left\{ \left(\frac{a - \sqrt{\Delta}}{6}, \frac{a + \sqrt{\Delta}}{6}, \frac{a + \sqrt{\Delta}}{6}, \frac{a - \sqrt{\Delta}}{6}, a, b, b \right) : a, b \in R \right\} \cup \\ \left\{ \left(\frac{a + \sqrt{\Delta}}{6}, \frac{a - \sqrt{\Delta}}{6}, \frac{a - \sqrt{\Delta}}{6}, \frac{a + \sqrt{\Delta}}{6}, a, b, b \right) : a, b \in R \right\}$$

If we write $x = a$ and $y^2 = -(\frac{a^2}{3} + 12b)$ then:

$$S_f = \left\{ \left(\frac{x - y}{6}, \frac{x + y}{6}, \frac{x + y}{6}, \frac{x - y}{6}, x, -\frac{x^2 + 3y^2}{36}, -\frac{x^2 + 3y^2}{36} \right) : x, y \in R \right\}$$

S_f is a smooth surface in $R^2 \times R^2 \times R^3$. The projection of S_f on $R^2 \times R^2$ is symmetric with respect to $D = \{(x, x), x \in R^2\}$. When $y = 0$ equivalently $\Delta = \frac{a^2}{3} + 12b = 0$, f has an A_3 singularity at $(\frac{x}{6}, \frac{x}{6}, x, -\frac{x^2}{36}, -\frac{x^2}{36})$.

6.2.3. The D_4^- case

The normal form of a D_4^- singularity of a function is given by $x^3 - 3xy^2$ and a versal

unfolding of this singularity is $f = x^3 - 3xy^2 + a(x^2 + y^2) + bx + cy$. The cubic $f = d$ has a line component if $c = 0, c = \sqrt{3}b$ or $c = -\sqrt{3}b$.

(i). $\underline{c = 0}$. Then $f - d = (x - \frac{a}{3})(x^2 - 3y^2 + \frac{4a}{3}x + \frac{4}{9}a^2 + b)$. The singularities of f are the points of intersection of the line $x - \frac{a}{3} = 0$ and the cone $x^2 - 3y^2 + \frac{4a}{3}x + \frac{4}{9}a^2 + b = 0$. Solving these equations simultaneously yields $x = \frac{a}{3}$ and $y = \pm\sqrt{\frac{a^2 + b}{3}}$ with the condition that $\Delta_1 = \frac{a^2 + b}{3} \geq 0$. A subset of S_f is then

$$S_1 = \{(\frac{a}{3}, \sqrt{\Delta_1}, \frac{a}{3}, -\sqrt{\Delta_1}, a, b, 0): a, b \in R\} \cup \\ \{(\frac{a}{3}, -\sqrt{\Delta_1}, \frac{a}{3}, \sqrt{\Delta_1}, a, b, 0): a, b \in R\}$$

If we write $x = \frac{a}{3}$ and $y^2 = \Delta_1 = \frac{a^2 + b}{3}$

$$S_1 = \{(x, y, x, -y, 3x, -9x^2 + 3y^2, 0), x, y \in R\}$$

S_1 is a smooth surface in $R^2 \times R^2 \times R^3$. When $y = 0$ (equivalently $\Delta_1 = a^2 + b = 0$), the function f has an A_3 singularity at points $(x, 0, 0, 0, 0)$.

(ii). $\underline{c = \sqrt{3}b}$. Then $f - d = (x + \sqrt{3}y + \frac{2}{3}a)(x^2 - \sqrt{3}xy + \frac{a}{3}x + \frac{\sqrt{3}}{3}ay - \frac{2}{9}a^2 + b)$.

We obtain the singularities of f by solving the system

$$x + \sqrt{3}y + \frac{2}{3}a = 0 \\ x^2 - \sqrt{3}xy + \frac{a}{3}x + \frac{\sqrt{3}}{3}ay - \frac{2}{9}a^2 + b = 0$$

When $\Delta_2 = a^2 - 2b \geq 0$, the system has real solutions and another subset of S_f is

$$S_2 = \{(\frac{a + 3\sqrt{\Delta_2}}{6}, \frac{\sqrt{3}(-a + \sqrt{\Delta_2})}{6}, -\frac{a - 3\sqrt{\Delta_2}}{6}, -\frac{\sqrt{3}(a + \sqrt{\Delta_2})}{6}, a, b, \sqrt{3}b)\} \cup \\ \{(-\frac{a - 3\sqrt{\Delta_2}}{6}, -\frac{\sqrt{3}(a + \sqrt{\Delta_2})}{6}, -\frac{a + 3\sqrt{\Delta_2}}{6}, -\frac{\sqrt{3}(a - \sqrt{\Delta_2})}{6}, a, b, \sqrt{3}b)\}$$

If we write $x = a$ and $y^2 = \Delta_2 = a^2 - 2b$, then

$$S_2 = \{(-\frac{x + 3y}{6}, \frac{\sqrt{3}(-x + y)}{6}, \frac{-x + 3y}{6}, -\frac{\sqrt{3}(x + y)}{6}, x, \frac{x^2 - y^2}{2}, \frac{\sqrt{3}(x^2 - y^2)}{2})\}$$

S_2 is a smooth surface. The function f has an A_3 singularity when $y = 0$, that is on the curve $(-\frac{1}{6}x, -\frac{\sqrt{3}}{6}x, x, \frac{1}{2}x^2, \frac{\sqrt{3}}{2}x^2)$ in $R^2 \times R^3$.

(iii). $\underline{c = -\sqrt{3}b}$. Similar calculations to those above lead to another subset of S_f

$$S_3 = \{(\frac{-a + 3\sqrt{\Delta_3}}{6}, \frac{\sqrt{3}(a + \sqrt{\Delta_3})}{6}, -\frac{a + 3\sqrt{\Delta_3}}{6}, \frac{\sqrt{3}(a - \sqrt{\Delta_3})}{6}, a, b, -\sqrt{3}b)\} \cup \\ \{(-\frac{a + 3\sqrt{\Delta_3}}{6}, \frac{\sqrt{3}(a - \sqrt{\Delta_3})}{6}, \frac{-a + 3\sqrt{\Delta_3}}{6}, \frac{\sqrt{3}(a + \sqrt{\Delta_3})}{6}, a, b, -\sqrt{3}b)\}$$

We write $x = a$ and $y^2 = \Delta_3$ and obtain a simple expression for S_3 .

$$S_3 = \left\{ \left(-\frac{x+3y}{6}, \frac{\sqrt{3}(x-y)}{6}, \frac{-x+3y}{6}, \frac{\sqrt{3}(x+y)}{6}, x, \frac{x^2-y^2}{2}, -\frac{\sqrt{3}(x^2-y^2)}{2} \right), x, y \in R \right\}$$

S_3 is a smooth surface. The function f has an A_3 singularity when $y = 0$. The set of the A_3 singularities of f is the curve $(-\frac{1}{6}x, \frac{\sqrt{3}}{6}x, x, \frac{1}{2}x^2, -\frac{\sqrt{3}}{2}x^2)$. The set S_f is

$$S_f = S_1 \cup S_2 \cup S_3$$

6.2.4. The case A_4

A normal form of an A_4 singularity is $x^5 + y^2$ and a versal unfolding of it is $f = x^5 + y^2 + ax^3 + bx^2 + cx$. The singular points of f occur on the x -axis. The function f has two real singularities at the same level if there exists a scalar d for which the polynomial $x^5 + y^2 + ax^3 + bx^2 + cx + d$ has two repeated roots. Let x_1, x_2 be these repeated roots and x_3 the fifth root. Thus, $x^5 + y^2 + ax^3 + bx^2 + cx + d = (x - x_1)^2(x - x_2)^2(x - x_3)$. By comparing the coefficients we find

$$x_3 = -2(x_1 + x_2),$$

$$a = -3x_1^2 - 3x_2^2 - 4x_1x_2,$$

$$b = 2x_1^3 + 2x_2^3 + 8x_1^2x_2 + 8x_1x_2^2,$$

$$c = 4x_1^3x_2 + 4x_2^3x_1 + 9x_1^2x_2^2,$$

$$d = 2(x_1 + x_2)x_1^2x_2^2,$$

so that $S_f = \{(x_1, 0, x_2, 0, -3x_1^2 - 3x_2^2 - 4x_1x_2, 2x_1^3 + 2x_2^3 + 8x_1^2x_2 + 8x_1x_2^2, 4x_1^3x_2 + 4x_2^3x_1 + 9x_1^2x_2^2) \mid x_1, x_2 \in R\}$

S_f is a smooth surface in $R^2 \times R^2 \times R^3$.

6.2.5. The A_3 case

A normal form of an A_3 singularity is $x^4 + y^2$ and a versal unfolding of it is $f = x^4 + y^2 + ax^2 + bx$. The singularities of f lie on the x -axis. The function f has two real singularities at the same level if for some $d \in R$ the polynomial $x^4 + y^2 + ax^2 + bx + d$ has two real repeated roots, that is, $x^4 + y^2 + ax^2 + bx + d = (x - x_1)^2(x - x_2)^2$. This yields

$$x_2 = -x_1$$

$$a = -2x_1^2$$

$$b = 0$$

$$d = x_1^4$$

As we are dealing with the distance squared function in R^3 , we shall consider a versal unfolding with three parameters. Such a versal unfolding can be written

$F(x, y, a, b, c) = f(x, y, a, b)$ with f as above. From the above calculations

$$S_F = \{(x_1, 0, -x_1, 0, -2x_1^2, 0, c) \mid x_1, c \in R\}$$

S_F is a smooth surface in $R^2 \times R^2 \times R^3$.

6.2.6. The A_2^2 case

The distance squared function has two A_2^2 singularities at the same level. The normal form of an A_2^2 singularity is given by a bi-germ of functions and the standard unfolding is

$$f(x_1, y_1, x_2, y_2, a_1, a_2, a_3) = \begin{cases} x_1^3 + y_1^2 + a_1 x_1 + a_3 \\ x_2^3 + y_2^2 + a_2 x_1 - a_3 \end{cases}$$

The bi-germ f has two singularities at the same level if and only if $a_1 = -3x_1^2, a_2 = -3x_2^2$ and $a_3 = x_1^3 - x_2^3$. Thus,

$$S_f = \{(x_1, 0, x_2, 0, -3x_1^2, -3x_2^2, x_1^3 - x_2^3)\}$$

§3. The structure of the midpoint locus of Surfaces

The midpoint locus of a generic smooth surface M is the set of midpoints of chords joining two points of contact of bitangent spheres to the surface. (Of course at an A_3, A_4 or D_4 point on the surface, the chord joining two nearby point of contact of bitangent sphere reduces to a point as these pairs of points tend to the A_3, A_4 or D_4 point on the surface.) Let $s : R^2 \rightarrow M$ be a local parametrization of the surface at a given point p_0 . (In A_2^2 case we shall take a local parametrization of the surface at each A_2 point.) The “midpoint map” which locates the midpoints of the chords joining two points on the surface is $m : R^2 \times R^2 \rightarrow R^3$ with $m(x, y) = \frac{1}{2}(s(x) + s(y))$. The midpoint map is symmetric with respect to the diagonal $\{(x, x) : x \in R^2\}$ in $R^2 \times R^2$, i.e., $m(x, y) = m(y, x)$.

The points of contact of bitangent spheres with the surface are those points where the distance squared function d has two singularities at the same level. If f is a versal unfolding of a singularity of d , then the set of points of contact of bitangent spheres with the surface is $pr \circ H(S_f)$ (diagram below).

$$\begin{array}{ccc} R^2 \times R^2 \times R^3 & \xrightarrow{H} & R^2 \times R^2 \times R^3 \\ & & \downarrow pr \\ & & R^2 \times R^2 \end{array}$$

Here H is the diffeomorphism defined in the proof of Lemma 6.2.1. The midpoint locus of the surface M is then locally $m(pr \circ H(S_f))$. For each case dealt with in section 2, we shall show, using a geometric argument, that $pr \circ H(S_f)$ is a smooth surface, symmetric with respect to the diagonal (for the cases D_4^+, A_4, A_3) or a union

of three smooth surfaces each of which is symmetric with respect to the diagonal (for the case D_4^-). The midpoint map folds these surfaces to surfaces with boundary.

6.3.1. Proposition : *The midpoint locus of a surface at a D_4^+ point is locally a surface with boundary. The boundary is the ridge line on the surface.*

Proof: Recall from 6.2.2 that

$$S_f = \left\{ \left(\frac{x-y}{6}, \frac{x+y}{6}, \frac{x+y}{6}, \frac{x-y}{6}, x, -\frac{x^2+3y^2}{36}, -\frac{x^2+3y^2}{36} \right) \right\}$$

It follows from the expression of H in Lemma 6.2.1 that

$$\begin{aligned} pr \circ H(S_f) = & \left\{ \left(\phi \left(\frac{x-y}{6}, \frac{x+y}{6}, x, -\frac{x^2+3y^2}{36}, -\frac{x^2+3y^2}{36} \right), \right. \right. \\ & \left. \left. \phi \left(\frac{x+y}{6}, \frac{x-y}{6}, x, -\frac{x^2+3y^2}{36}, -\frac{x^2+3y^2}{36} \right) \right) : x, y \in R \right\} \end{aligned}$$

Clearly $pr \circ H(S_f) = pr(S_d)$ is symmetric with respect to the diagonal $D = \{(x, x) : x \in R^2\}$. In order to prove that it is a smooth surface it is enough to show that at the D_4^+ point there are two smooth curves in $pr \circ H(S_f)$ meeting transversally and deduce that the restriction of $pr \circ H$ to S_f is a submersion in a neighbourhood of this point.

The natural curves to consider are the images of the x and y -axis. The image of the curve $y = 0$ is $\ell_1 = \left\{ \left(\phi \left(\frac{x}{6}, \frac{x}{6}, x, -\frac{x^2}{36}, -\frac{x^2}{36} \right), \phi \left(\frac{x}{6}, \frac{x}{6}, x, -\frac{x^2}{36}, -\frac{x^2}{36} \right) \right) \right\}$. As pointed out in 6.2.2 the curve $\left\{ \left(\frac{x}{6}, \frac{x}{6}, x, -\frac{x^2}{36}, -\frac{x^2}{36} \right) \right\}$ is the set of A_3 singularities of f , hence $\left\{ \phi \left(\frac{x}{6}, \frac{x}{6}, x, -\frac{x^2}{36}, -\frac{x^2}{36} \right) : x \in R \right\}$ is the preimage of the ridge line of the surface M . We know that this line is smooth close to the D_4^+ point $[\mathbf{Po}]$. Therefore ℓ_1 is a smooth curve lying on the diagonal D .

The second curve ℓ_2 , image of $x = 0$, is parametrized by $\left(\phi \left(-\frac{y}{6}, \frac{y}{6}, 0, -\frac{y^2}{12}, -\frac{y^2}{12} \right), \phi \left(\frac{y}{6}, -\frac{y}{6}, 0, -\frac{y^2}{12}, -\frac{y^2}{12} \right) \right)$. Its tangent line at the origin is $\left(-\frac{\partial \phi}{\partial x_1} + \frac{\partial \phi}{\partial x_2}, \frac{\partial \phi}{\partial x_1} - \frac{\partial \phi}{\partial x_2} \right)$, where (x_1, x_2, a, b, c) denotes the coordinates in $R^2 \times R^3$ and $\frac{\partial \phi}{\partial x_i}$, $i = 1, 2$ are evaluated at the origin. Since $\phi(-, 0)$ is a diffeomorphism, $-\frac{\partial \phi}{\partial x_1} + \frac{\partial \phi}{\partial x_2} \neq 0$. The curve ℓ_2 is then a smooth curve and meets ℓ_1 transversally on the diagonal D .

The image of the curve ℓ_1 by the midpoint map is the ridge line

$\alpha_0(x) = s \left(\phi \left(\frac{x}{6}, \frac{x}{6}, x, -\frac{x^2}{36}, -\frac{x^2}{36} \right) \right)$ on the surface. This is a smooth curve on the surface M (but this does not imply $\alpha'_0(0) \neq 0$). By counting the number of conditions, we deduce that generically at a D_4^+ point $\alpha'_0(0) \neq 0$. The curve

$$\alpha_{y_0}(x) = m\left(\left(\phi\left(\frac{x-y_0}{6}, \frac{x+y_0}{6}, x, -\frac{x^2+3y_0^2}{36}, -\frac{x^2+3y_0^2}{36}\right), \phi\left(\frac{x+y_0}{6}, \frac{x-y_0}{6}, x, -\frac{x^2+3y_0^2}{36}, -\frac{x^2+3y_0^2}{36}\right)\right)\right)$$

is then smooth for y_0 near the origin.

Let β_0 be the image by m of the image of the curve $x = 0$ in $pr \circ H(S_f)$. That is

$$\beta_0(y) = \frac{1}{2}\left[s\left(\phi\left(-\frac{y}{6}, \frac{y}{6}, 0, -\frac{y^2}{12}, -\frac{y^2}{12}\right)\right) + s\left(\phi\left(\frac{y}{6}, -\frac{y}{6}, 0, -\frac{y^2}{12}, -\frac{y^2}{12}\right)\right)\right]$$

We can choose coordinates so that $s(x, y) = (x, y, a(x^2 + y^2) + O_3(x, y))$. It is clear that $\beta_0(y) = \beta_0(-y)$ and $\beta'_0(0) = 0$. We have

$$\beta''_0(0) = Ds(0)\left(\frac{1}{36}\frac{\partial^2\phi}{\partial x_1^2} + \frac{1}{36}\frac{\partial^2\phi}{\partial x_2^2} - \frac{1}{6}\frac{\partial\phi}{\partial a_2} - \frac{1}{6}\frac{\partial\phi}{\partial a_3}\right) + D^2s(0)\left(-\frac{1}{6}\frac{\partial\phi}{\partial x_1} + \frac{1}{6}\frac{\partial\phi}{\partial x_2}\right)^2$$

But

$$Ds(0) = \begin{pmatrix} 1 & 0 \\ 0 & 1 \\ 0 & 0 \end{pmatrix}$$

and

$$D^2s(0) = \begin{pmatrix} 0 & 0 & 0 & 0 \\ 0 & 0 & 0 & 0 \\ 2a & 0 & 0 & 2a \end{pmatrix}$$

Therefore for generic D_4^+ on the surface $\beta''_0(0) \neq 0$ and its z -component is also non-zero. The curve β_0 is then a smooth curve with an end point (at the origin) lying on the ridge line, and its limiting tangent direction there is not on the tangent plane to the surface at the origin.

We can consider nearby curves β_{x_0} , image by the midpoint map of the image of the curve $x = x_0$ in $pr \circ H(S_f)$, and show by continuity of β'' that $\beta''_{x_0}(0) \neq 0$. The curve β_{x_0} is then smooth with an end point lying on the ridge line, and it is transverse to the curve α_{y_0} , for x_0, y_0 near the origin. The restriction of the map m to $pr \circ H(S_f)$ is of rank 1 on $pr \circ H(S_f) \cap D$ and of rank 2 elsewhere. The midpoint locus is therefore locally a surface with boundary and the boundary is the ridge line on the surface. \square

6.3.2. Proposition : *The midpoint locus at a D_4^- is locally a union of three surfaces with boundary. The boundaries are the ridge lines on the surface.*

Proof: From 6.2.3, S_f is the union of three smooth surfaces S_1, S_2 and S_3 . We shall show, following the same procedure in Proposition 6.3.1, that each of $pr \circ H(S_i)$ ($i = 1, 2, 3$) is a smooth surface.

We have $S_1 = \{(x, y, x, -y, 3x, -9x^2 + 3y^2, 0) : x, y \in R\}$, and using the expression for H in Lemma 6.2.1 we obtain

$$pr \circ H(S_1) = \{(\phi(x, y, 3x, -9x^2 + 3y^2, 0), \phi(x, -y, 3x, -9x^2 + 3y^2, 0)) : x, y \in R^2\}$$

The function f in 6.2.3 has A_3 singularities on the curve $(x, 0, 3x, -9x^2, 0)$. This curve is taken by ϕ to $\{\phi(x, 0, 3x, -9x^2, 0) : x \in R\}$, the preimage of one of the ridge lines which we know is smooth $[\mathbf{Po}]$. Hence $\{(\phi(x, 0, 3x, -9x^2, 0), \phi(x, 0, 3x, -9x^2, 0))\}$ is a smooth curve in $pr \circ H(S_1)$.

The second curve to consider is the image of the y -axis. It is parametrized by $(\phi(0, y, 0, 3y^2, 0), \phi(0, -y, 0, 3y^2, 0))$. Its tangent vector at the origin is $(\frac{\partial \phi}{\partial x_2}, -\frac{\partial \phi}{\partial x_2})$. Since $\phi(-, 0)$ is locally a diffeomorphism, $\frac{\partial \phi}{\partial x_2} \neq 0$. The curve

$(\phi(0, y, 0, 3y^2, 0), \phi(0, -y, 0, 3y^2, 0))$ is smooth and it is clear that it meets the first considered curve transversally.

We show, following the same approach, that $pr \circ H(S_2)$ and $pr \circ H(S_3)$ are smooth surfaces. These three surfaces are symmetric with respect to the diagonal D . We also show, as in Proposition 6.3.1, that for generic D_4^- points on the surface the midpoint map maps each of these surfaces to a surface with boundary. The boundaries are the ridge lines on the surface. It follows by considering the curve β_0'' as in Proposition 6.3.1, that generically at the origin, the limiting tangent planes to the midpoint locus are not tangent to the surface M . Again counting the number of conditions, these limiting tangent planes meet transversally in a corner at generic D_4^- points. (Figure 6.3.1.) \square

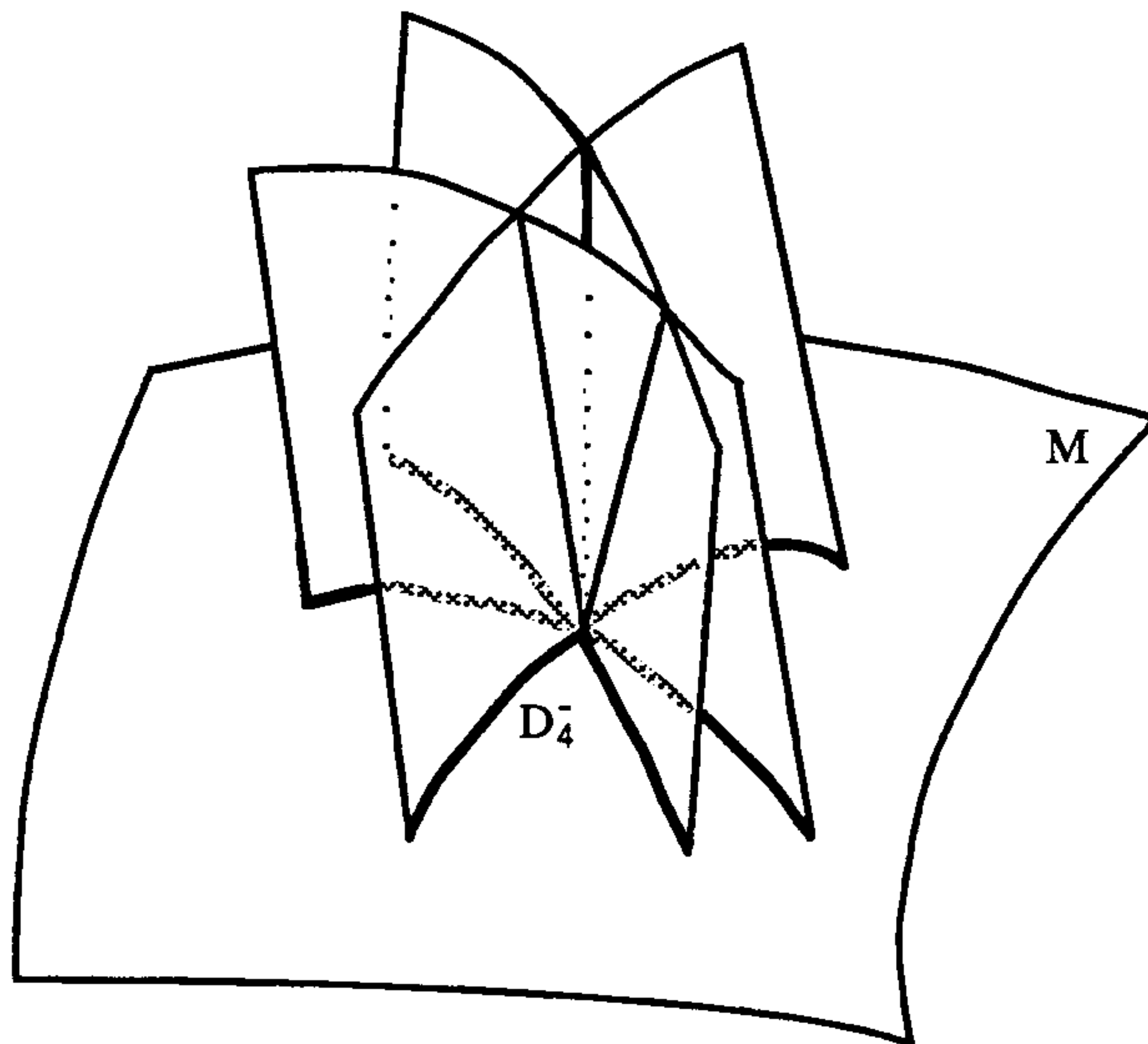

Figure 6.3.1. The midpoint locus at a D_4^- point

6.3.3. Proposition : *The midpoint locus at an A_4 is a smooth surface with boundary. The boundary is the ridge line on the surface.*

Proof: From 6.2.4 and the expression of H it follows that

$$pr \circ H(S_f) =$$

$$\{(\phi(x_1, 0, -3x_1^2 - 3x_2^2 - 4x_1x_2, 2x_1^3 + 2x_2^3 + 8x_1^2x_2 + 8x_1x_2^2, 4x_1^3x_2 + 4x_2^3x_1 + 9x_1^2x_2^2), \\ \phi(x_2, 0, -3x_1^2 - 3x_2^2 - 4x_1x_2, 2x_1^3 + 2x_2^3 + 8x_1^2x_2 + 8x_1x_2^2, 4x_1^3x_2 + 4x_2^3x_1 + 9x_1^2x_2^2))\}$$

The images of the curves $x_1 = x_2$ and $x_1 = -x_2$ are smooth and transverse, thus $pr \circ H(S_f)$ is locally a smooth surface in $R^2 \times R^2$. Its image by the midlocus map is generically a surface with boundary. The boundary is the ridge line on the surface. \square

6.3.4. Proposition : *The midpoint locus at an A_3 is a smooth surface with boundary. The boundary is the ridge line on the surface.*

Proof: From 6.2.5 and the expression of H it follows that

$$pr \circ H(S_f) = \{(\phi(x, 0, -2x^2, 0, c), \phi(-x, 0, -2x^2, 0, c)): x, c \in R\}$$

The curve $\{\phi(0, 0, 0, 0, c) \mid c \in R\}$ is the preimage of the ridge line. It is a smooth curve, hence $\{(\phi(0, 0, 0, 0, c), \phi(0, 0, 0, 0, c)) \mid c \in R\}$ is a smooth curve in $pr \circ H(S_f)$. The image of $c = 0$ $\{(\phi(x, 0, -2x^2, 0, 0), \phi(-x, 0, -2x^2, 0, 0)) \mid x \in R\}$ is also a smooth curve which meets the above curve transversally. Thus $pr \circ H(S_f)$ is a smooth surface. Its image by the midpoint map is generically a surface with boundary and the boundary is the ridge line on the surface (figure 6.3.2). \square

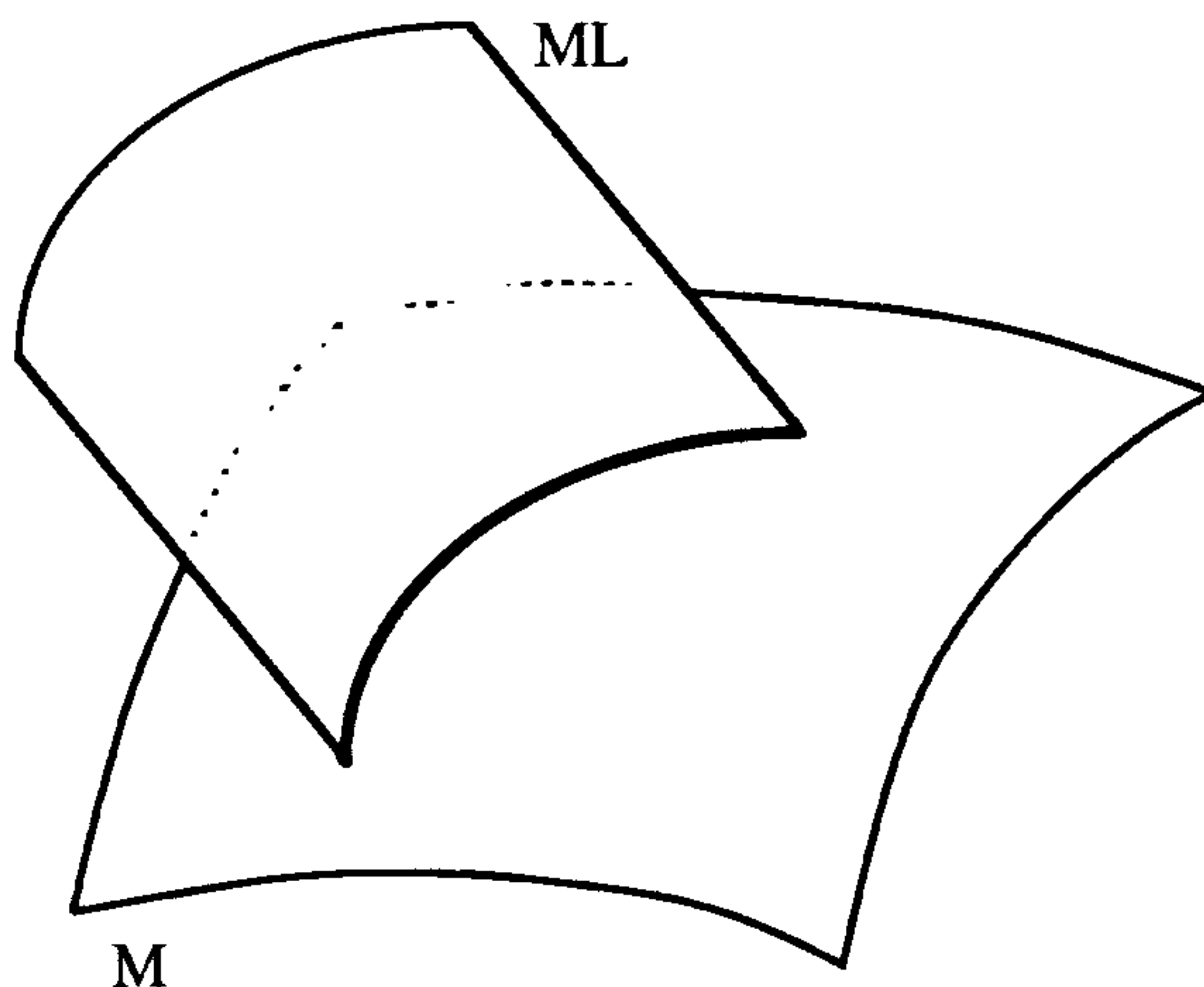

Figure 6.3.2. The midpoint locus at an A_3 point

6.3.5. Proposition : *The midpoint locus at an A_2^2 is locally a smooth surface.*

Proof : It follows from 6.2.6 and Lemma 6.2.1 that

$$pr \circ H(S_f) = \{(\phi_1(x_1, 0, -3x_1^2, -3x_2^2, x_1^3 - x_2^3), \phi_2(x_2, 0, -3x_1^2, -3x_2^2, x_1^3 - x_2^3))\}$$

This is a smooth surface in $R^2 \times R^2$ and for generic A_2^2 points, the image of $pr \circ H(S_f)$ by the midpoint map is a smooth surface. \square

6.3.6. The tangent space to the midpoint locus at smooth points

In this section we give an explicit formula for finding the tangent vectors to the midpoint locus. Suppose that there is a sphere of radius t_0 tangent to the surface M at two points $s(x_0)$ and $s(y_0)$. We can construct locally the following map

$$f : R^2 \times R^2 \times R \longrightarrow R^3$$

$$(x, y, t) \longmapsto s(x) + tN(s(x)) - s(y) - tN(s(y))$$

The zero set of f , $f^{-1}(0)$, is the set of points in the parameter space which correspond to the points of contact of bitangent spheres to the surface. The projection of $f^{-1}(0)$ to $R^2 \times R^2$ is a smooth surface (as in Proposition 6.2.6), and the tangent vectors are the projections of the kernel vectors of $Df(0)$ to $R^2 \times R^2$. Let (ξ, ζ, τ) be in the kernel of $Df(0)$. Then,

$$[Ds(x) + tDN(s(x))Ds(x)]\xi - [Ds(y) + tDN(s(y))Ds(y)]\zeta + [N(x) - N(y)]\tau = 0 \quad (*)$$

If we write $\bar{\xi} = Ds(x)\xi$ and $\bar{\zeta} = Ds(y)\zeta$, the equation $(*)$ becomes

$$[1 - tSh(s(x))]\bar{\xi} - [1 - tSh(s(y))]\bar{\zeta} = -[S(x) - S(y)]\tau \quad (**)$$

where Sh denotes the shape operator of the surface M and 1 the identity on R^2 . The map $Sh(s(x))$ is a map from the tangent plane $T_{s(x)}M = R^2$ to itself, and it is given by $Sh(s(x)) = -DN(s(x))Ds(x)$. The equation (**) is equivalent to saying that $[1 - tSh(s(x))] \bar{\xi} - [1 - tSh(s(y))] \bar{\zeta}$ is parallel to $(S(x) - S(y))$.

Let u be a common unit tangent direction to the surface M at $s(x)$ and $s(y)$. We can think of u as being the unit vector director of the line of intersection of the tangent planes to the surface M at $s(x)$ and $s(y)$. Let $\{u, v\}$ and $\{u, w\}$ be orthonormal bases for the tangent spaces to the surface M at $s(x)$ and $s(y)$ respectively. We write $[1 - tSh(s(x))] \bar{\xi} = au + bv$ and $[1 - tSh(s(y))] \bar{\zeta} = cu + dw$ for some a, b, c, d in R . We then have

$$[1 - tSh(s(x))] \bar{\xi} - [1 - tSh(s(y))] \bar{\zeta} = (a - c)u + bv - dw$$

and the condition for the equation (**) to be satisfied is $a = c$ and $b = -d$. So,

$$[1 - tSh(s(x))] \bar{\xi} = au + bv$$

$$[1 - tSh(s(y))] \bar{\zeta} = au - bw$$

By differentiating the midpoint map $m(x_1, x_2) = \frac{1}{2}(s(x) + s(y))$, one can see that the tangent vectors to the midpoint locus are of the form $\bar{\xi} + \bar{\zeta}$. At an $A_1 A_1$ point on the surface, the sphere is not osculating, its radius t is not an eigenvalue of either of the matrices $Sh(s(x))$ and $Sh(s(y))$. The matrices $[1 - tSh(s(x))]$ and $[1 - tSh(s(y))]$ are invertible and the tangent vectors to the midpoint locus are given by

$$[1 - tSh(s(x))]^{-1}(au + bv) + [1 - tSh(s(y))]^{-1}(au - bw)$$

At an A_2^2 point, the bitangent sphere of radius t_0 is bi-osculating at $s(x)$ and $s(y)$. The scalar t_0 is an eigenvalue of the matrices $Sh(s(x))$ and $Sh(s(y))$, and each corresponding eigenvector is one of the principal directions of the surface M at $s(x)$ and $s(y)$. Let V_x and V_y be these principal directions. The tangent space to the midpoint locus is spanned by V_x and V_y . Indeed, $[1 - tSh(s(x))]V_x = 0u + 0v$, $[1 - tSh(s(y))]V_y = 0u - 0w$ and for generic A_2^2 points V_x and V_y are linearly independent. Thus:

6.3.7. *The tangent plane to the midpoint locus at an A_2^2 is spanned by the principal directions V_x and V_y .*

References

- [A1] V.I.Arnold, Normal form for functions near degenerate critical points, the Weyl groups of A_n , D_n , E_n and Lagrangean singularities, *Functional ansl.app.* **6** (1972), 254-272.
- [A2] V.I.Arnold, Wavefront evolution and equivariant Morse lemma. *Comm. Pure. App. Math.* **29** (1976), 557-582.
- [A3] V.I.Arnold, Indices of singular points of 1-forms on a manifold with boundary, the convolution of invariants of groups generated by reflexions, and the singular projections of smooth surfaces, *Russian Math.Surveys*, **34** (1979), 1-42.
- [A4] V.I.Arnold, *Catastrophe theory*, Springer-Verlag 1984 (2nd edition 1986).
- [Bl] H.Blum, Biological shape and visual science (part I), *J.Theor.Biol.* (1973) **38**, 205-287.
- [Bra] M.Brady, Criteria for representation of shape in *Human and Machine Vision*. Beck and Rosenfield, Eds. Academic Press 1983.
- [Br-L] T.Bröker and J.Lander, Differential germs and catastrophes, *London Math. Soc, Lectures Notes* 17. Cambridge University Press.
- [B1] J.W.Bruce, Generic functions on semi-algebraic sets, *Quart. J. Math. Oxford* (2) **37** (1986), 137-165.
- [B2] J.W.Bruce, Geometry Of Singular Sets. Preprint, University of Newcastle-upon-Tyne, 1988.
- [B-dP] J.W.Bruce and A.A.duPlessis, Classification of map-germs. Preprint.
- [B-dP-W] J.W.Bruce, A.A.duPlessis and C.T.C.Wall, Determinacy and unipotency, *Invent.Math.*, **88** (1987), 521-554.
- [B-G1] J.W.Bruce and P.J.Giblin, Curves and Singularities, Cambridge University Press (1984).

- [B-G2] J.W.Bruce and P.J.Giblin, Outlines and their duals, *Proc.Lond.Math.Soc.*, **50** (1985), 552-570.
- [B-G3] J.W.Bruce and P.J.Giblin, Growth, Motion and 1-parameter families of symmetry sets, *Proc. Roy .Soc. Edinburgh* **104A** (1986), 179-204.
- [B-G4] J.W.Bruce and P.J.Giblin, Projections of surfaces with boundary, *Proc.London Math.Soc.* (3) **60** (1990) 392-416.
- [B-G-Gi] J.W.Bruce, P.J.Giblin and C.G.Gibson, Symmetry Sets, *Proc. Roy. Soc. Edinburgh* **101A** (1985), 163-186.
- [B-Wi] J.W.Bruce and T.Wilkinson, Folding maps and focal sets, to appear in *Proceedings of Warwick Singularity Symposium 1989*.
- [C] J.Callahan, A note on projections of piecewise smooth surfaces. Unpublished.
- [D1] J.N.Damon, Topological triviality in versal unfoldings, *Proc.Sym.Pur.Math.*, **40** (1983) 255-266.
- [D2] J.N.Damon, The unfolding and determinacy theorems for subgroups of \mathcal{A} and \mathcal{K} , *Mem.Am.Math.Soc.*, **306** (1984).
- [D3] J.N.Damon, Topological triviality and versality for subgroups of \mathcal{A} and \mathcal{K} I, *Mem.Am.Math.Soc*, **389** (1988).
- [D4] J.N.Damon, Topological triviality and versality for subgroups of \mathcal{A} and \mathcal{K} . II. Sufficient conditions and applications. Preprint.
- [Ga] T.Gaffney, The structure of $T\mathcal{A}(f)$, classification and application to differential geometry, *Orlik, P.(ed.), Singularities. Proc. Symp. Pure Math.* **40** (part 1) 409-428 (1983).
- [G] P.J.Giblin, Local symmetry in the plane: Experiment and Theory in *Computers in Geometry and Topology*, Ed. M.C.Tangora. *Lecture Notes in Pure and Applied Mathematics* **114**(1989), 131-149. Pub. Marcel Dekker.

- [G-B] P.J.Giblin and S.A.Brassett, Local symmetry of plane curves, *Amer. Math. Monthly.* 92 (1985),689-707.
- [G-T] P.J.Giblin and F.Tari, Locall reflexional and rotational symmetry in the plane, to appear in *Proceedings of Warwick Singularity Symposium 1989.*
- [K] J.J.Koenderink and A.J.Van Doorn, The singularities of the visual mapping, *Bio.Cybernet.*, 24 (1976) 51-59.
- [Lu] Yung-Chen Lu, Singularity theory and an introduction to catastrophe theory. *Springer-Verlag* 1976.
- [Ma] J.Mather, Stability of C^∞ mappings III. Finitely determined map-germs, *Publ.Math.*, 89 (1969) 127-249.
- [Mc] C.McCrory, Profiles of surfaces. Preprint, University of Warwick, 1981.
- [M] R.J.Morris, Symmetry of curves and the geometry of surfaces. Two explorations with aid of computer graphics, *Ph.D thesis, University of Liverpool.*
- [P1] O.A.Platonova, Singularities of the mutual disposition of a surface and a line, *Russian Math.Surveys*, 36:1 (1981), 248-249.
- [P2] O.A.Platonova, Singularities of projections of smooth surfaces, *Russian Math.Surveys*, 39:1 (1984), 177-178.
- [Po] I.R.Porteous,The normal singularities of surfaces in R^3 , *Pro. Symp. Pure Math.*, 40 (part 2) (1983) 379-393.
- [R1] J.H.Rieger, Families of maps from the plane to the plane, *Jour.Lond.Math.Soc.* (2) 36 (1987),351-369.
- [R2] J.H.Rieger, On the classification of views of piecewise smooth objects, *Image and Vision Computing.* Vol 5 no 2 May 1987, 91-97.
- [Ro] M.Roberts, Characterisations of finitely datermined equivariant map germs, *Math. Ann*, 275 583-597, (1986).

- [T] F.Tari, Projections of piecewise smooth surfaces, to appear in *J. London Math.Soc.*
- [W1] C.T.C.Wall, Geometric Properties of generic differential manifolds in geometry and topology, Vol III, *Lectures Notes in Maths.*, **597** (Springer, 1976).
- [W2] C.T.C.Wall, Affine Cubic functions. II, the complex plane, *Math.Proc.Camb Phil Soc.* (1979), **85**, 387-401.
- [W3] C.T.C.Wall. Finite determinacy of smooth map-germs, *Bull.Lond.Math.Soc.*, **13** (1981), 481-539 .
- [W4] C.T.C.Wall, Equivariant jets, *Math.Ann* **272** (1985), no.1, 41-65.
- [Wh]. H.Whitney, On singularities of mappings of Euclidian space. I. Mappings of the plane to the plane, *Ann. of Math.* **62** (1955), 374-410.